

RVM/RVMS/RVP

VERTICAL MULTISTAGE CENTRIFUGAL PUMPS



Available with NEMA and IEC ELECTRIC MOTORS



CONTENTS

GENERAL DATA

Performance Scope	1
Product Range	1
Pump : Basic Information	2
Max. Working Pressure	3
Max. Ambient Temperature	3
Performance Curve	3
Curve Illustration	4
Min. Inlet Pressure NPSH	5
Operation in Parallel	5
Material	6

PERFORMANCE CURVES & TECHNICAL DATA

RVM/RVMS1, 60Hz	9-10
RVM/RVMS2, 60Hz	11-12
RVM/RVMS3, 60Hz	13-14
RVM/RVMS4, 60Hz	15-16
RVM/RVMS8, 60Hz	17-18
RVM/RVMS16, 60Hz	19-20
RVM/RVMS20, 60Hz	21-22
RVM/RVMS32, 60Hz	23-24
RVM/RVMS42, 60Hz	25-26
RVM/RVMS65, 60Hz	27-28
RVM/RVMS85, 60Hz	29-30

GENERAL DATA

PERFORMANCE SCOPE

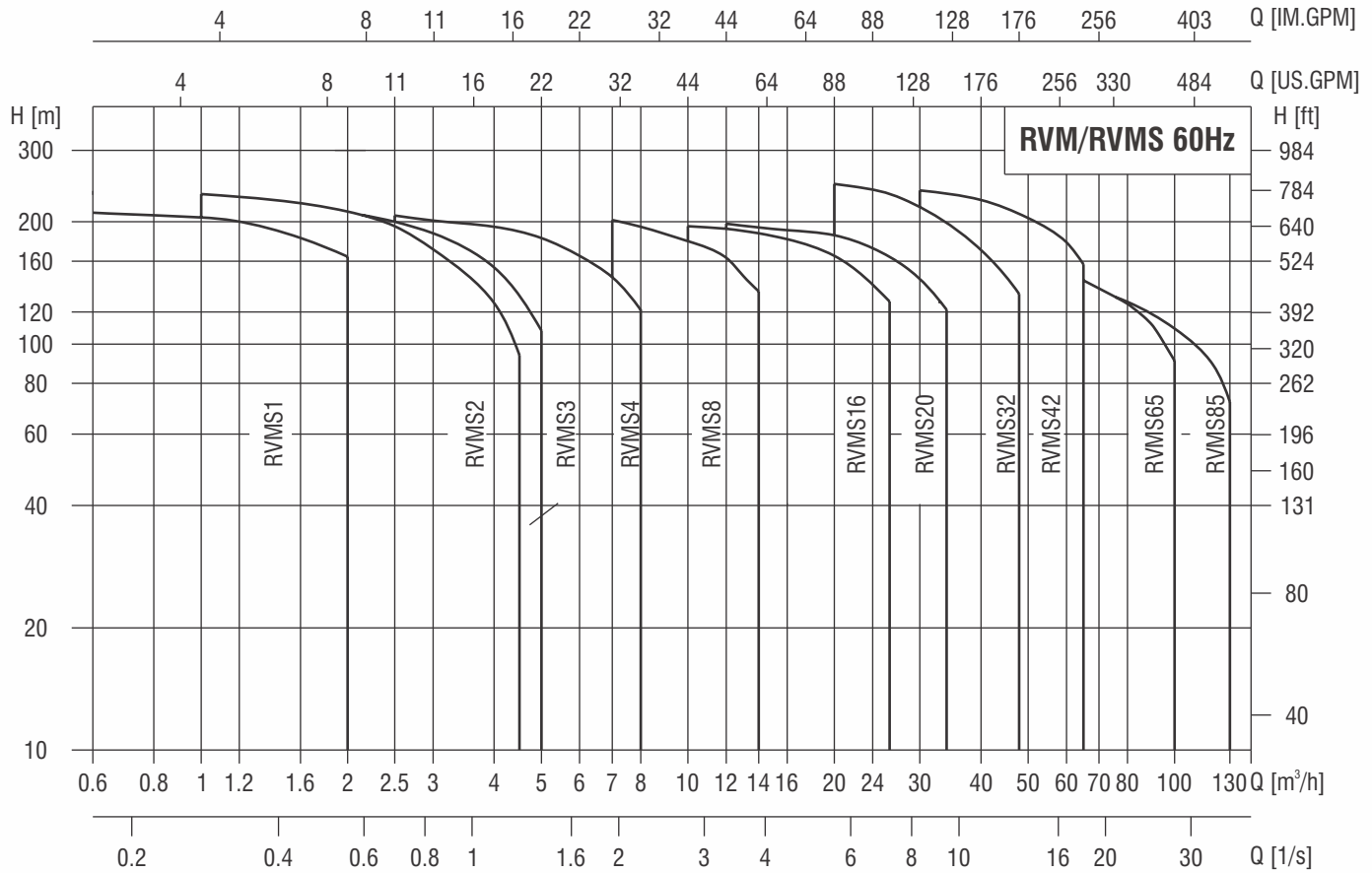

PRODUCT RANGE

DESCRIPTION	RVM1	RVM2	RVM3	RVM4	RVM8	RVM16	RVM20	RVM32	RVM42	RVM65	RVM85
Rated Flow [m³/h]	1	2	3	4	8	16	20	32	42	65	85
Rated Flow [l/s]	0.28	0.56	0.83	1.1	2.2	4.4	5.6	8.9	11.7	18	24
Flow Range [m³/h]	0.6-2	1-4.5	1.5-5	2.5-8	7-14	10-26	12-34	20-48	30-65	40-100	60-130
Flow Range [l/s]	0.17-0.56	0.28-1.25	0.7-2.2	0.7-2.2	1.9-3.9	2.8-7.2	3.3-9.4	5.5-13.3	8.3-18	11.1-27.7	16.7-36.1
Max. Pressure [bar]	22	23.5	23	21	20	20	20	25	26	18	15
Motor Power [kW]	0.37-2.2	0.55-3.7	0.37-3.7	0.75-5.5	0.75-11	2.2-18.5	2.2-18.5	2.2-30	5.5-45	7.5-45	11-45
Temperature Range [°C]	-15°C ~ +120°C										
Max. Efficiency [%]	44	46	54	57	62	66	69	73	75	76	77
Pump Type	-15°C ~ +120°C										
RVM	●	●	●	●	●	●	●	●	●	●	●
RVMS	●	●	●	●	●	●	●	●	●	●	●
RVM Pipe Connection											
ANSI Flange	1"	1"	1"	1 1/4"	1 1/2"	2"	2"	2 1/2"	3"	4"	4"
RVMS Pipe Connection											
ANSI Flange	1"	1"	1"	1 1/4"	1 1/2"	2"	2"	2 1/2"	3"	4"	4"

GENERAL DATA

PUMP

RVM / RVMS / RVP is vertical non-self priming multistage centrifugal pump, which is driven by a standard electric motor. The motor output shaft directly connects with the pump shaft through a coupling. The pressure-resistant cylinder and flow passage components are fixed between pump head and inlet & outlet section with tie-bar bolts. The inlet and outlet are located at the pump bottom at the same plane.

OPERATION CONDITIONS

- Thin, clean, non-flammable & non-explosive liquid containing no solid granules and fibres.
- Liquid temperature:
Normal Temperature type: $-15^{\circ}\text{C} \sim +70^{\circ}\text{C}$,
Hot Water type: $-15^{\circ}\text{C} \sim +120^{\circ}\text{C}$
- Ambient temperature: upto $+40^{\circ}\text{C}$
- Altitude: upto 1000m

IDENTIFICATION OF PUMP

RVM / RVMS1, 2, 3, 4, 8, 16 and 20

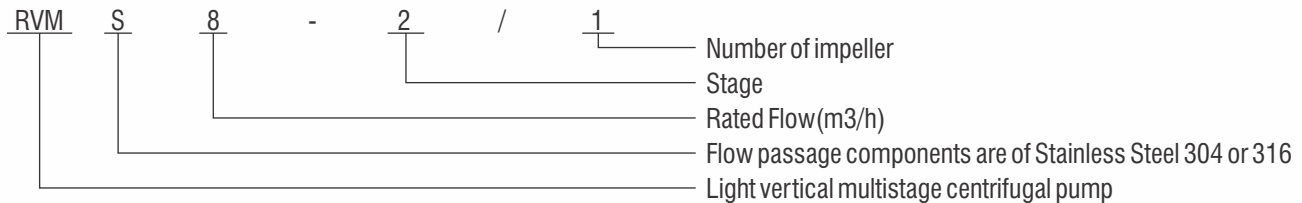

RVM / RVMS32, 42, 65 and 85

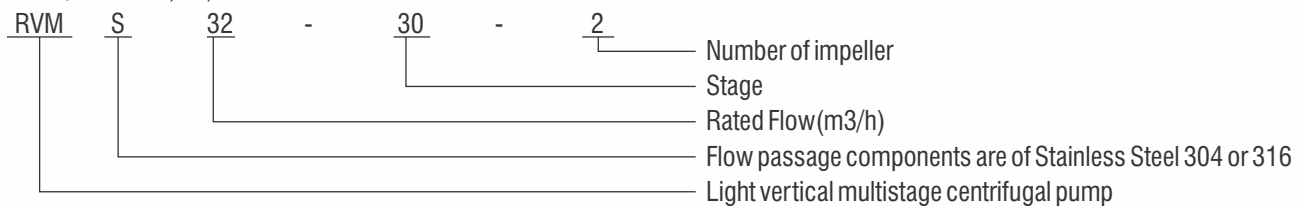

- **Water Supply:** Water filtration, transporting liquid to Water works, pressure boosting of main line, Pressure boosting in High-Rise buildings.
- **Industrial:** Pressure boosting, Process flow water system, cleaning system, high-pressure washing system, fire-fighting system.
- Industrial Liquid transfer, HVAC, boiler feed water application, condensing system.
- **Water treatment:** Ultra-filtration system, reverse osmosis system, distillation system, separator, swimming pool.
- **Irrigation:** Farmland irrigation, spray irrigation, dripping irrigation.

MOTOR

- Full-enclosed air-blast two pole standard motor
- Protection class: Ip55
- Insulation class: F
- Standard Voltage: 60Hz: 3ph, 208-230/460V
3ph, 208-230/380-440V
3ph, 575V

APPLICATION

RVM type pump is used for pumping non-corrosive liquid, while RVMS / RVP type pump is suitable for pumping slightly corrosive liquid. RVM Pump is provided with cast iron base & cast iron Flange connections, while RVMS is provided with standard cast iron base & Stainless Steel Flange connections. RVP is provided with standard cast iron base & Stainless Steel NPT threaded connections.

MAX WORKING PRESSURE

MODEL	CURVE NUMBER
60Hz	
RVM/RVMS1,2,3,4	2
RVM/RVMS8,16,20	3
RVM/RVMS32	
32-10-1 ~ 32-50-2	1(*)
32-50 ~ 32-90	4(*)
32-90 ~ 32-100-2	5
RVM/RVMS42	
42-10-1 ~ 42-30	1(*)
42-40-2 ~ 42-60	4(*)
42-70-2 ~ 42-70	5
RVM/RVMS65	
65-10-1 ~ 65-30	1(**)
65-40-2 ~ 65-50-2	4
RVM/RVMS85	
85-10-1 ~ 85-30	1(**)
85-40-2	4

* For Curve5, need to specify especially;

** For curve 4, need to specify especially

The Following figure shows the limitation of pressure and temperature, which shall be kept within the region as shown in the figure.

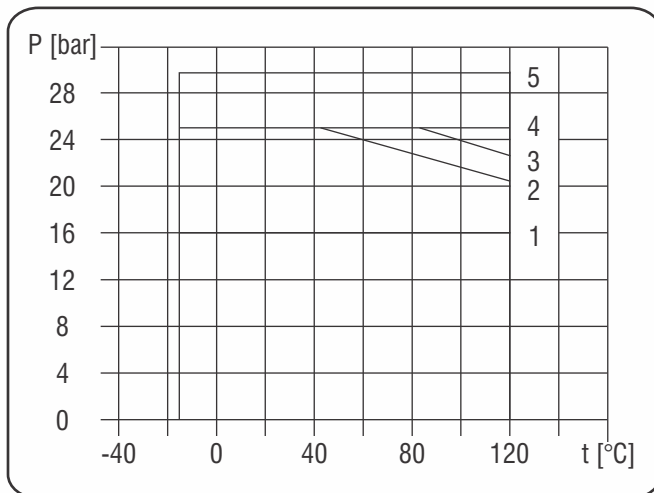

MAX. AMBIENT TEMPERATURE

When the pump operates at ambient temperature higher than 40°C or at an altitude higher than 1000m, because of low air density and poor cooling effects, the motor output power P2 will be decreased to certain extent. If the pump is operated at the above said conditions, it should be equipped with motor of higher power.

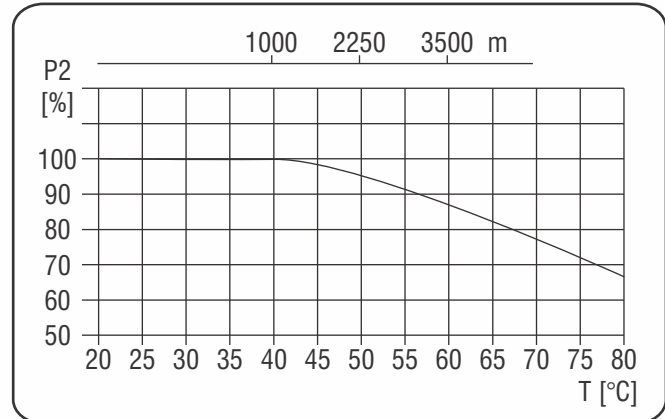

PERFORMANCE

CURVE

Following Conditions are suitable for the Performance curves shown below:

1. All curves are based on the measured values of constant motor speed 3500 r/min
2. Curve tolerance in conformity with ISO9906 Annex A.
3. Measurement is done with 20 °C air-free water, kinematic viscosity of 1mm²/sec.
4. The operation of pump shall refer to the performance region indicated by the thickened curve to prevent overheating due to small flow rate or overload of motor due to too large flow rate.

CURVE ILLUSTRATION

Stage
 First Number:
 Stagex10
 Second Digit:
 Number of small impeller

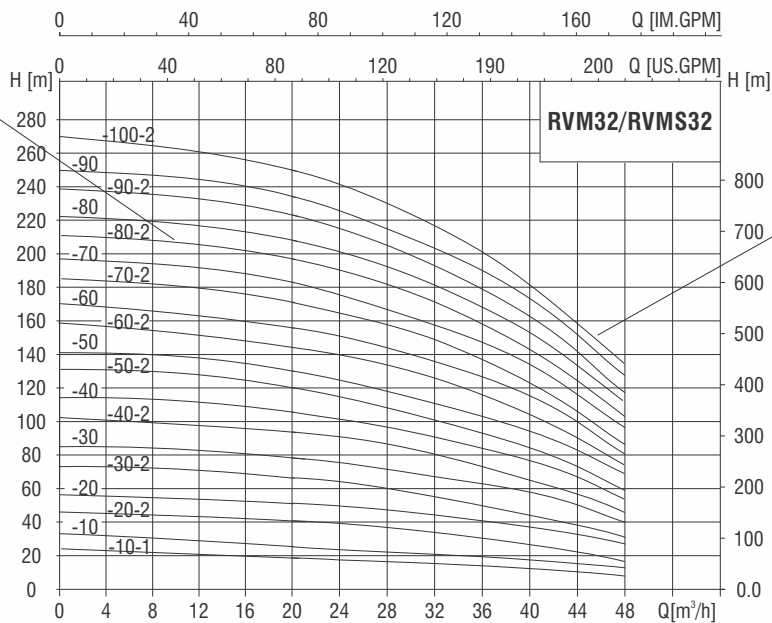

Pump Q-H curve, the thickened line represents recommended performance region

The power curve represents the input power of each stage, which is divided into integrate impeller type (1/1) and the type with small impeller (2/3)

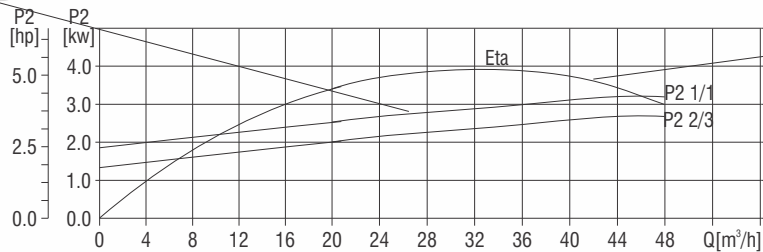

Eta curve represents efficiency of the pump, For the pump equipped with small impeller, its efficiency will be 2% lower than that shown by the curve.

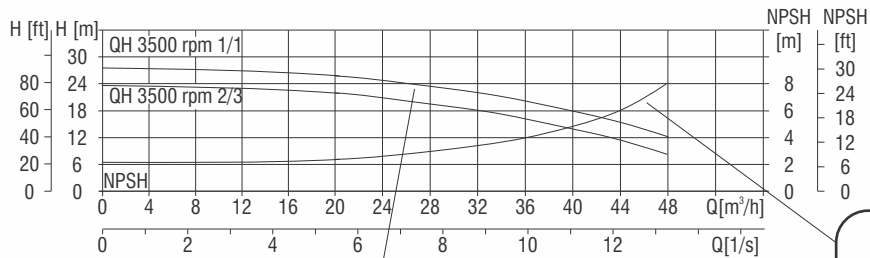

The Q-H curve of each stage, represents integrate impeller type (1/1) and the type equipped with small impeller (2/3)

NPSH curve expresses the average value of all curves of this series. A safety margin of 0.5m shall be taken into consideration when making selection.

MINIMUM INLET PRESSURE NPSH

In case that the pressure in pump is lower than the steam pressure used to pump liquid, the cavitation will take place. To avoid cavitation, a minimum pressure at the inlet side of the pump shall be guaranteed. The maximum suction stroke can be calculated with following formula:

$$H = P_b \times 10.2 - \text{NPSH} - H_f - H_v - H_s$$

P_b = atmosphere pressure [bar]
(can be set as 1 bar)

In a closed system, P_b means system pressure [bar]

NPSH = Net positive suction head [m]

(It can be read out from the point of possible max.

flow rate shown on NPSH curve)

H_f = Pipeline loss at the inlet [m]

H_v = Steam pressure [m]

H_s = Safety margin = Minimum 0.5m delivery head

If the calculated result H is positive, the pump may run under the max. Suction stroke H .

In case the calculated result H is negative, a delivery head of min. Inlet pressure is necessary.

OPERATION IN PARALLEL

Connecting several pumps in parallel running will benefit much more than running a single large pump.

- Applicable to different working states necessary in a variable flow system.
- Increasing the possibility of water supply when the pump is in failure. Because in case of pump failure, only part of the system flow is effected.

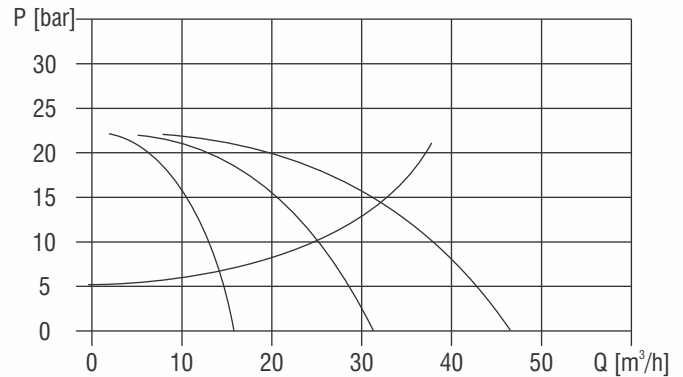

Two pumps or more can be connected in parallel running if necessary.

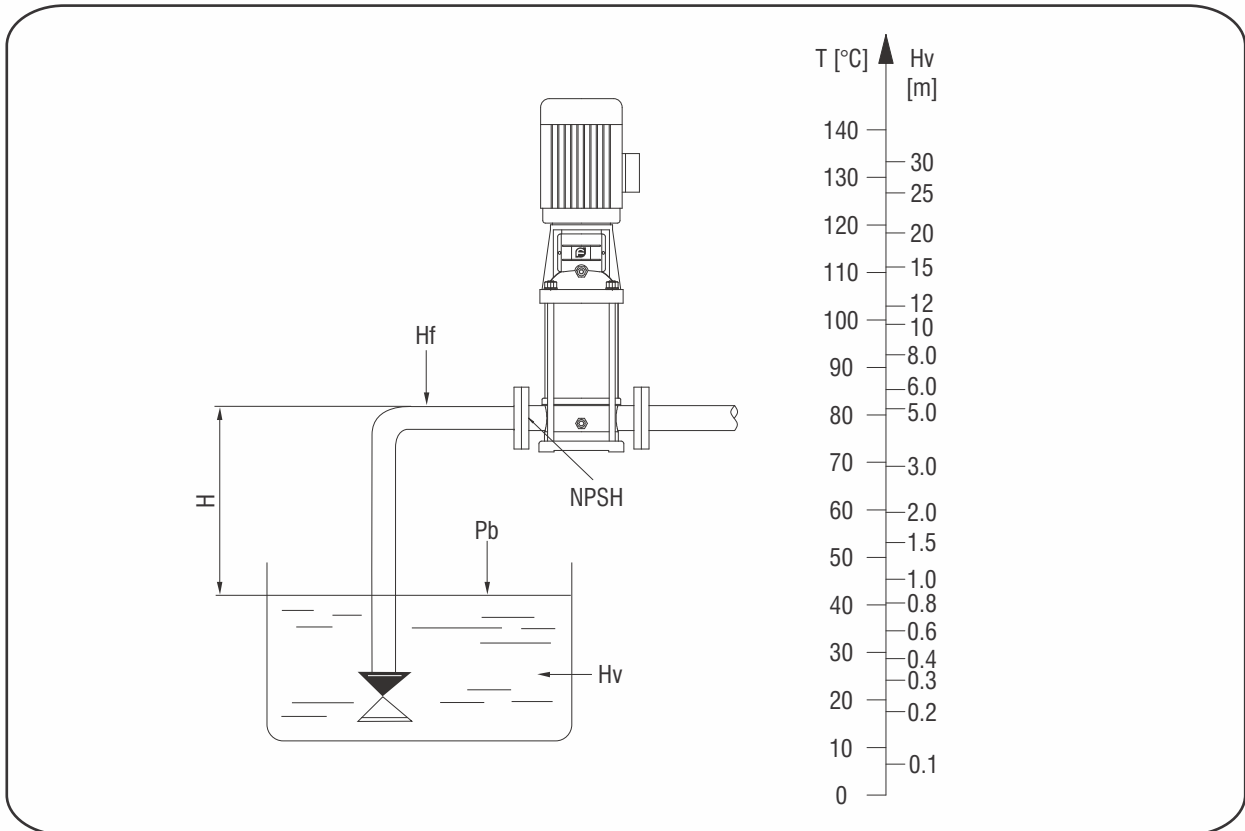

Check and ensure that the pump is not at cavitation state

SECTIONAL DRAWING

RVM/RVMS1, 2, 3, 4

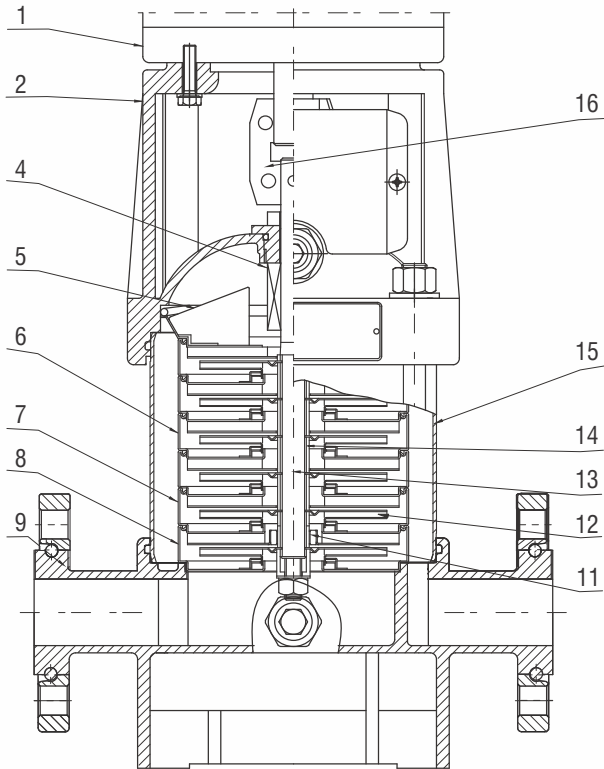

RVM

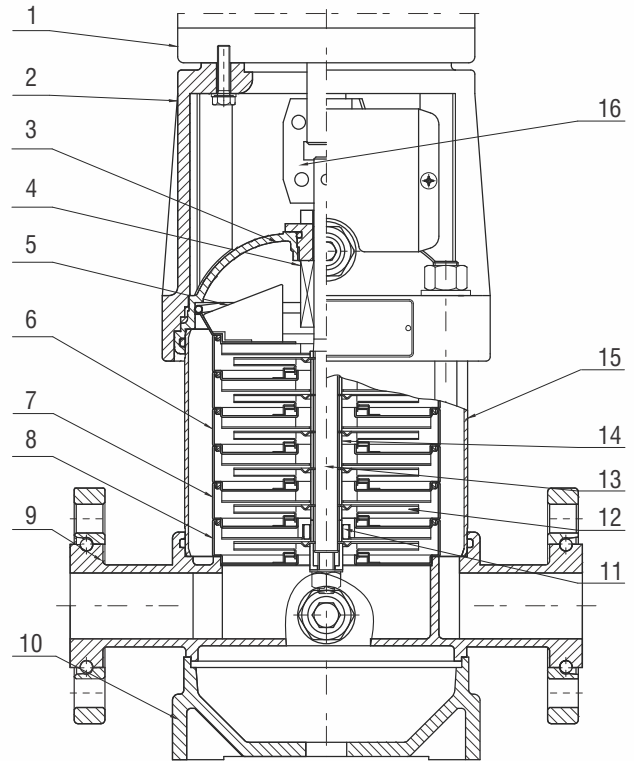

RVMS

MATERIAL OF CONSTRUCTION RVM/RVMS1, 2, 3, 4

NO.	NAME	MATERIAL	AISI/ASTM
1	Motor		
2	Pump Head	Cast Iron	ASTM A48 CL25
4	Mechanical Seal	Ca/TC/Viton	
5	Top Diffuser	Stainless Steel	AISI304
6	Diffuser	Stainless Steel	AISI304
7	Support Diffuser	Stainless Steel	AISI304
8	Inducer	Stainless Steel	AISI304
11	Bearing	Tungsten Carbide	
12	Impeller	Stainless Steel	AISI304
13	Shaft	Stainless Steel	AISI304/AISI316
14	Impeller Sleeve	Stainless Steel	AISI304
15	Cylinder	Stainless Steel	AISI304
16	Coupling	Carbon Steel	

NO.	NAME	MATERIAL	AISI/ASTM
RVMS			
3	Seal Base	Stainless Steel	AISI304
9	Inlet & Outlet Chamber	Stainless Steel	AISI304
10	Base Plate	Cast Iron	ASTM A48 CL25
RVM			
9	Inlet & Outlet Chamber	Cast Iron	ASTM A48 CL25

SECTIONAL DRAWING

RVM/RVMS8, 16, 20

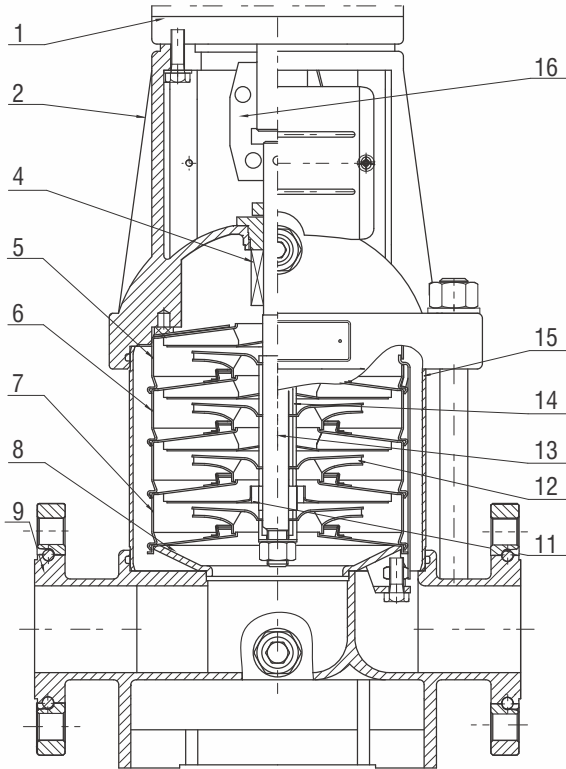

RVM

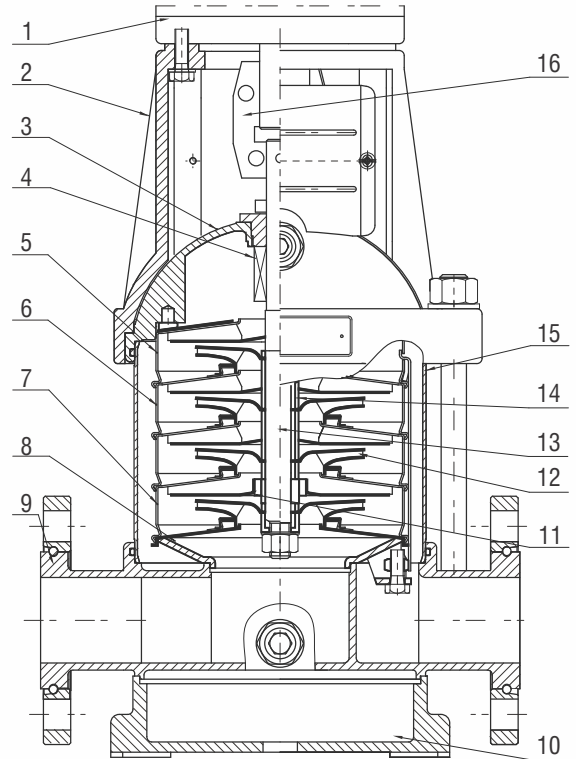

RVMS

MATERIAL OF CONSTRUCTION RVM/RVMS8, 16, 20

NO.	NAME	MATERIAL	AISI/ASTM
1	Motor		
2	Pump Head	Cast Iron	ASTM A48 CL25
4	Mechanical Seal	Ca/TC/Viton	
5	Top Diffuser	Stainless Steel	AISI304
6	Diffuser	Stainless Steel	AISI304
7	Support Diffuser	Stainless Steel	AISI304
8	Inducer	Stainless Steel	AISI304
11	Bearing	Stainless Steel	
12	Impeller	Stainless Steel	AISI304
13	Shaft	Stainless Steel	AISI304/AISI316
14	Impeller Sleeve	Stainless Steel	AISI304
15	Cylinder	Stainless Steel	AISI304
16	Coupling	Carbon Steel	

NO.	NAME	MATERIAL	AISI/ASTM
RVMS			
3	Seal Base	Stainless Steel	AISI304
9	Inlet & Outlet Chamber	Stainless Steel	ASTM A48 CL25
10	Base Plate	Cast Iron	ASTM A48 CL25
RVM			
9	Inlet & Outlet Chamber	Cast Iron	ASTM A48 CL25

SECTIONAL DRAWING

RVM/RVMS32, 42, 65, 85

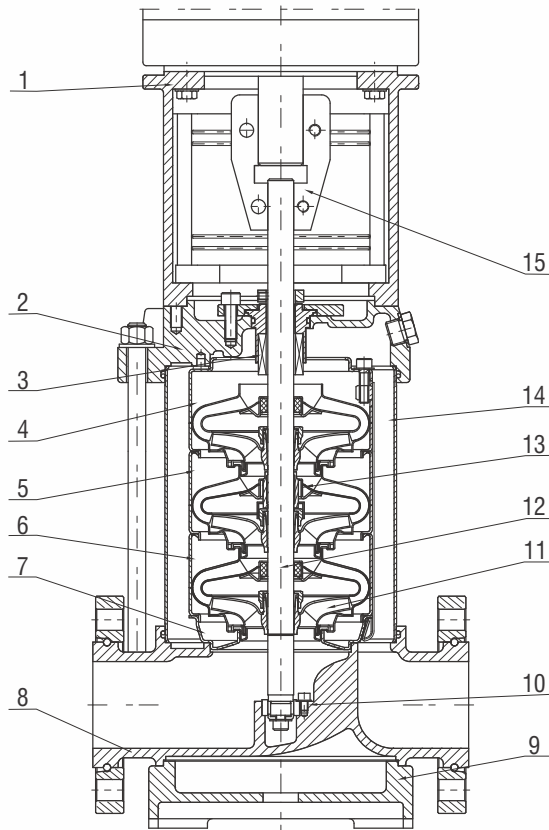

MATERIAL OF CONSTRUCTION RVM/RVMS32, 42, 65, 85

NO.	NAME	MATERIAL	AISI/ASTM
1	Bracket	Cast Iron	ASTM A48 CL25
3	Mechanical Seal	Ca/TC/Viton	
4	Top Diffuser	Stainless Steel	AISI304
5	Support Diffuser	Stainless Steel	AISI304
6	Diffuser	Stainless Steel	AISI304
7	Inducer	Stainless Steel	AISI304
9	Base Plate	Cast Iron	ASTM A48 CL25
10	Bottom Bearing	Stainless Steel	
11	Impeller	Stainless Steel	AISI304
12	Shaft	Stainless Steel	AISI316, AISI304 AISI431
13	Immediate Bearing	Stainless Steel	
14	Cylinder	Stainless Steel	AISI304
15	Coupling	Carbon Steel	
	Rubber Parts	NBR	

NO.	NAME	MATERIAL	AISI/ASTM
RVMS			
2	Pump Head	Cast Iron	ASTM A48 CL30
8	Inlet & Outlet Chamber	Cast Iron	ASTM A48 CL30
RVM			
2	Pump Head	Stainless Steel	AISI304
8	Inlet & Outlet Chamber	Stainless Steel	AISI304

PERFORMANCE CURVE

RVM/RVMS1, 60HZ

ISO9906 Annex A

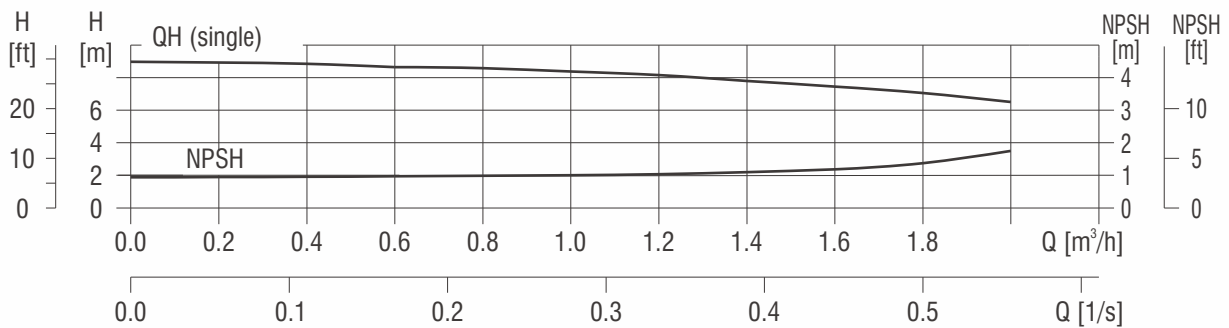
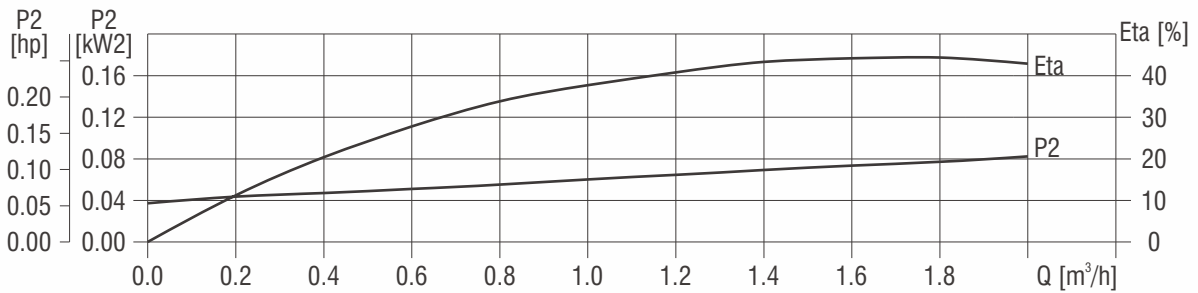
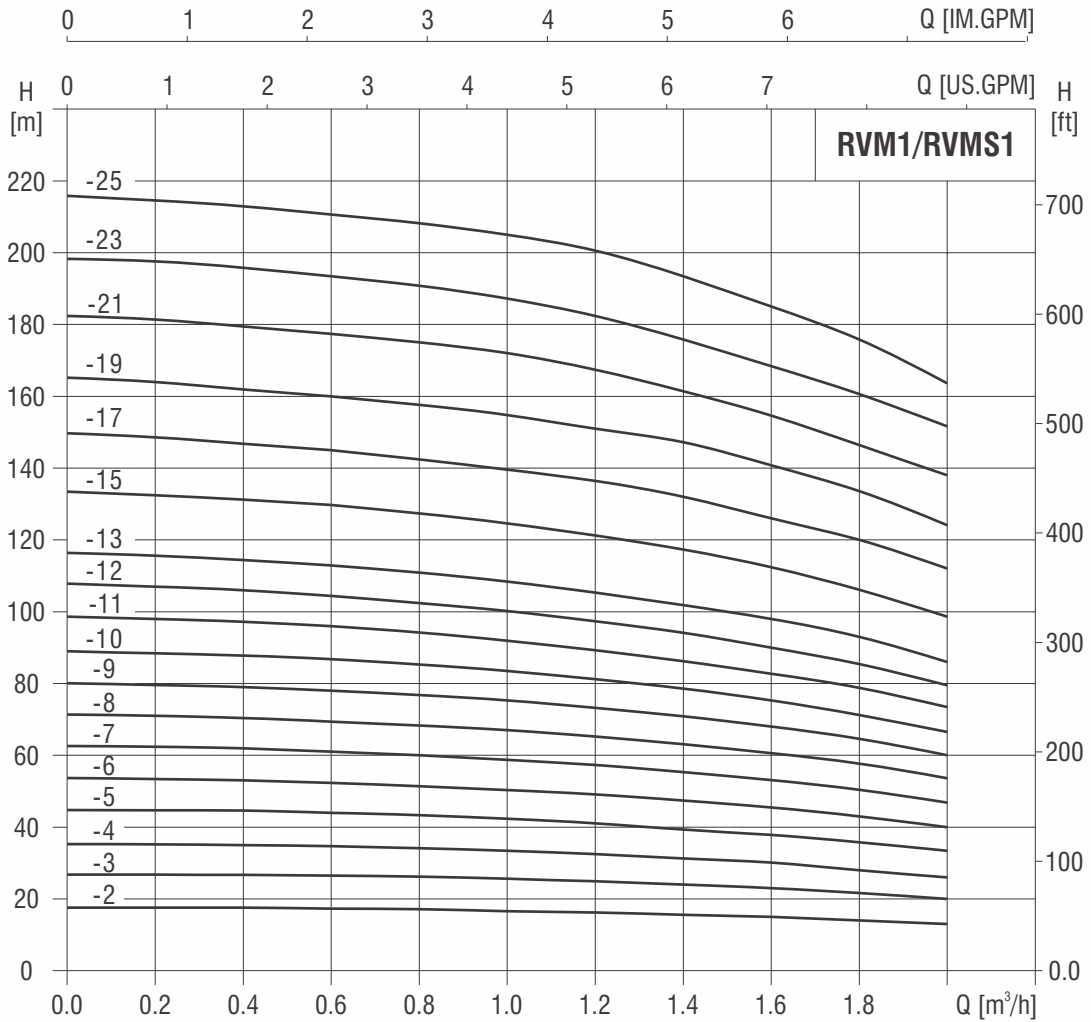

PERFORMANCE TABLE

MODEL	DRIVING MOTOR		FRAME	Q(m ³ /h)	0.6	0.8	1	1.2	1.4	1.6	1.8	2
	(kW)	(hp)										
RVM1-2	0.37	0.5	56C	H[m]	17.5	17	16.5	16	15.5	15	14	13
RVM1-3	0.37	0.5	56C		26.5	26	25	24	23	22	21	20
RVM1-4	0.37	0.5	56C		35	34	33	32	31	30	28	26
RVM1-5	0.55	0.75	56C		43	42	41	40	39	38	35	33
RVM1-6	0.55	0.75	56C		52	51	50	48	47	45	43	39
RVM1-7	0.75	1	56C		60	59	58	56	55	52	50	46
RVM1-8	0.75	1	56C		68	67	65	64	62	59	57	53
RVM1-9	0.75	1	56C		76	75	74	73	71	66	64	60
RVM1-10	1.1	1.5	56C		85	84	83	81	78	74	72	67
RVM1-11	1.1	1.5	56C		95	93	90	87	85	81	78	73
RVM1-12	1.1	1.5	56C		103	102	98	96	92	88	86	79
RVM1-13	1.1	1.5	56C		112	110	107	105	100	95	93	86
RVM1-15	1.5	2	56C		127	125	123	121	117	112	107	99
RVM1-17	1.5	2	56C		144	141	139	137	132	124	120	112
RVM1-19	2.2	3	182TC		160	157	155	153	147	141	134	124
RVM1-21	2.2	3	182TC		177	174	172	168	162	153	147	138
RVM1-23	2.2	3	182TC		193	190	188	184	174	167	161	152
RVM1-25	2.2	3	182TC		210	207	205	202	192	184	176	164

PUMP DIMENSIONS

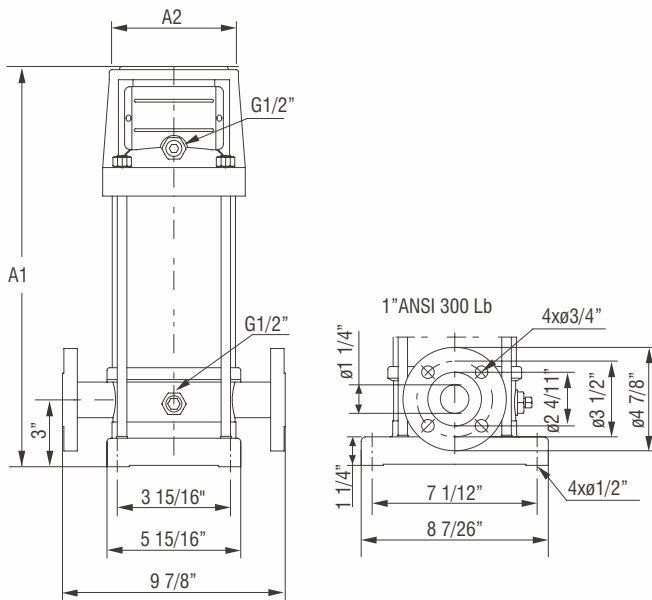

SIZE AND WEIGHT

MODEL	SIZE (INCH)		WEIGHT (lbs)
	A1	A2	
RVM1-2	11 1/4	6 1/2	34
RVM1-3	12	6 1/2	35
RVM1-4	12 11/16	6 1/2	36
RVM1-5	13 3/8	6 1/2	37
RVM1-6	14 1/8	6 1/2	39
RVM1-7	14 13/16	6 1/2	40
RVM1-8	15 9/16	6 1/2	41
RVM1-9	16 1/4	6 1/2	42
RVM1-10	16 15/16	6 1/2	43
RVM1-11	17 11/16	6 1/2	44
RVM1-12	18 3/8	6 1/2	45
RVM1-13	19 1/16	6 1/2	46
RVM1-15	20 1/2	6 1/2	49
RVM1-17	21 15/16	6 1/2	51
RVM1-19	23 5/8	8 7/8	56
RVM1-21	25 1/16	8 7/8	57
RVM1-23	26 1/2	8 7/8	60
RVM1-25	27 7/8	8 7/8	62

PERFORMANCE CURVE

RVM/RVMS2, 60HZ

ISO9906 Annex A

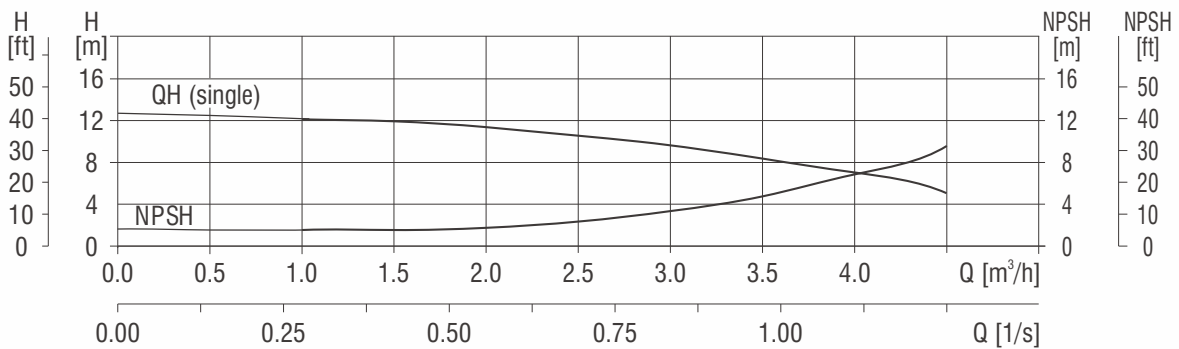
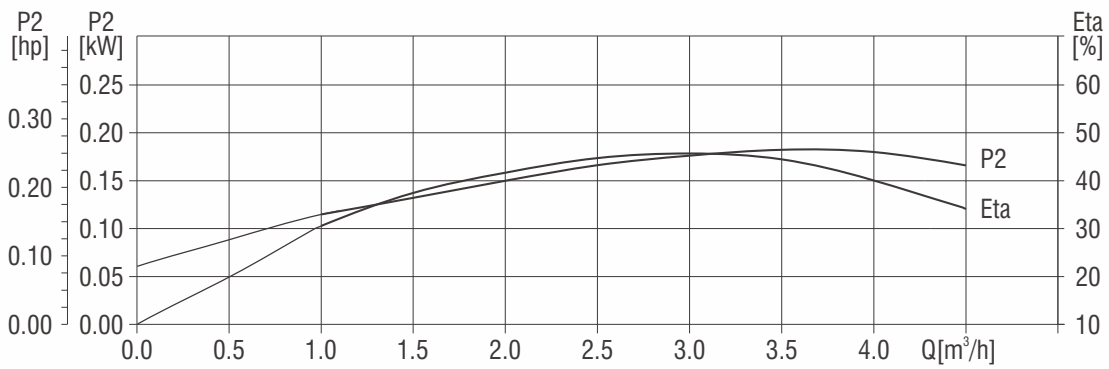
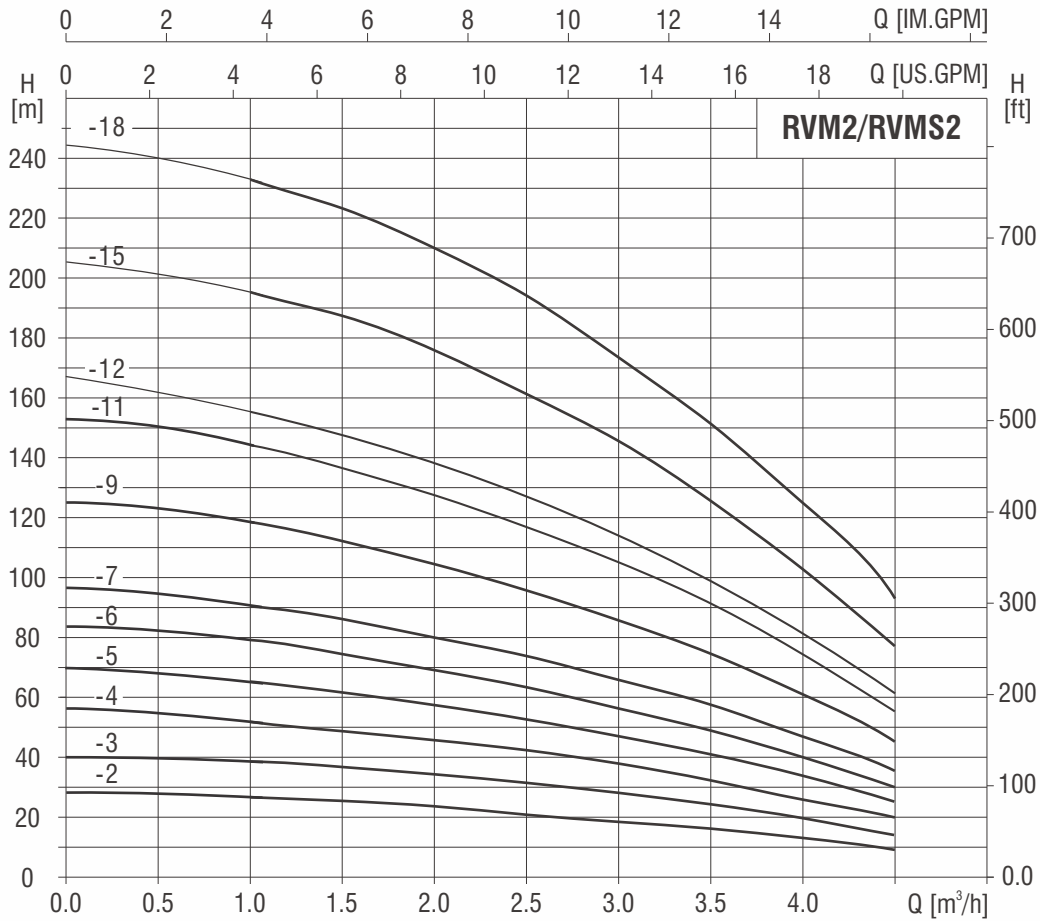

PERFORMANCE TABLE

MODEL	DRIVING MOTOR		FRAME	Q(m ³ /h)	1	1.5	2	2.5	3	3.5	4	4.5
	(kW)	(hp)										
RVM2-2	0.55	0.75	56C	H[m]	26	24	22	21	18	16	12	9
RVM2-3	0.75	1	56C		39	36	33	31	27	24	19	15
RVM2-4	1.1	1.5	56C		52	48	45	42	36	32	26	20
RVM2-5	1.1	1.5	56C		65	60	57	52	46	41	32	25
RVM2-6	1.1	1.5	56C		78	74	69	63	56	49	40	30
RVM2-7	1.5	2	56C		91	86	81	74	66	57	47	35
RVM2-9	2.2	3	182TC		117	111	104	95	86	75	61	45
RVM2-11	2.2	3	182TC		143	136	128	116	104	90	75	56
RVM2-12	2.2	3	182TC		156	149	139	126	114	98	82	61
RVM2-15	3.7	5	184TC		195	186	176	160	142	125	103	77
RVM2-18	3.7	5	184TC		234	228	212	195	171	151	126	94

PUMP DIMENSIONS

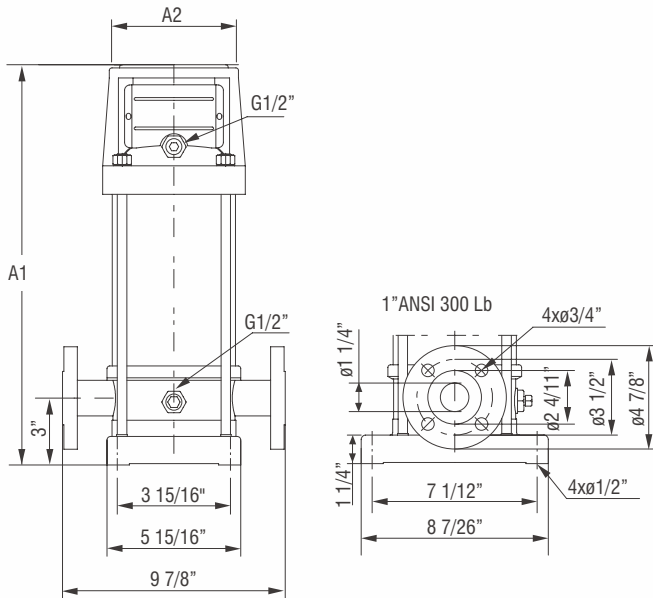

SIZE AND WEIGHT

MODEL	SIZE (INCH)		WEIGHT (lbs)
	A1	A2	
RVM2-2	11 1/4	6 1/2	34
RVM2-3	12	6 1/2	35
RVM2-4	12 11/16	6 1/2	36
RVM2-5	13 3/8	6 1/2	37
RVM2-6	14 1/8	6 1/2	39
RVM2-7	14 13/16	6 1/2	40
RVM2-9	16 9/16	8 7/8	42
RVM2-11	18	8 7/8	44
RVM2-12	18 11/16	8 7/8	50
RVM2-15	20 13/16	8 7/8	53
RVM2-18	22 15/16	8 7/8	55

PERFORMANCE CURVE

RVM/RVMS3, 60HZ

ISO9906 Annex A

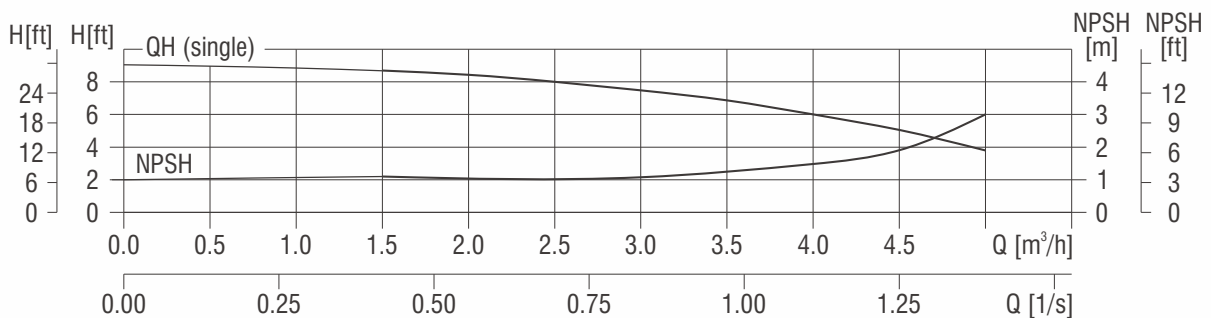
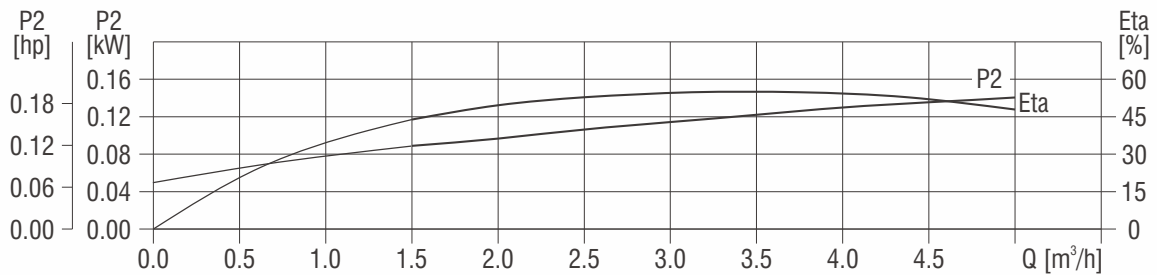
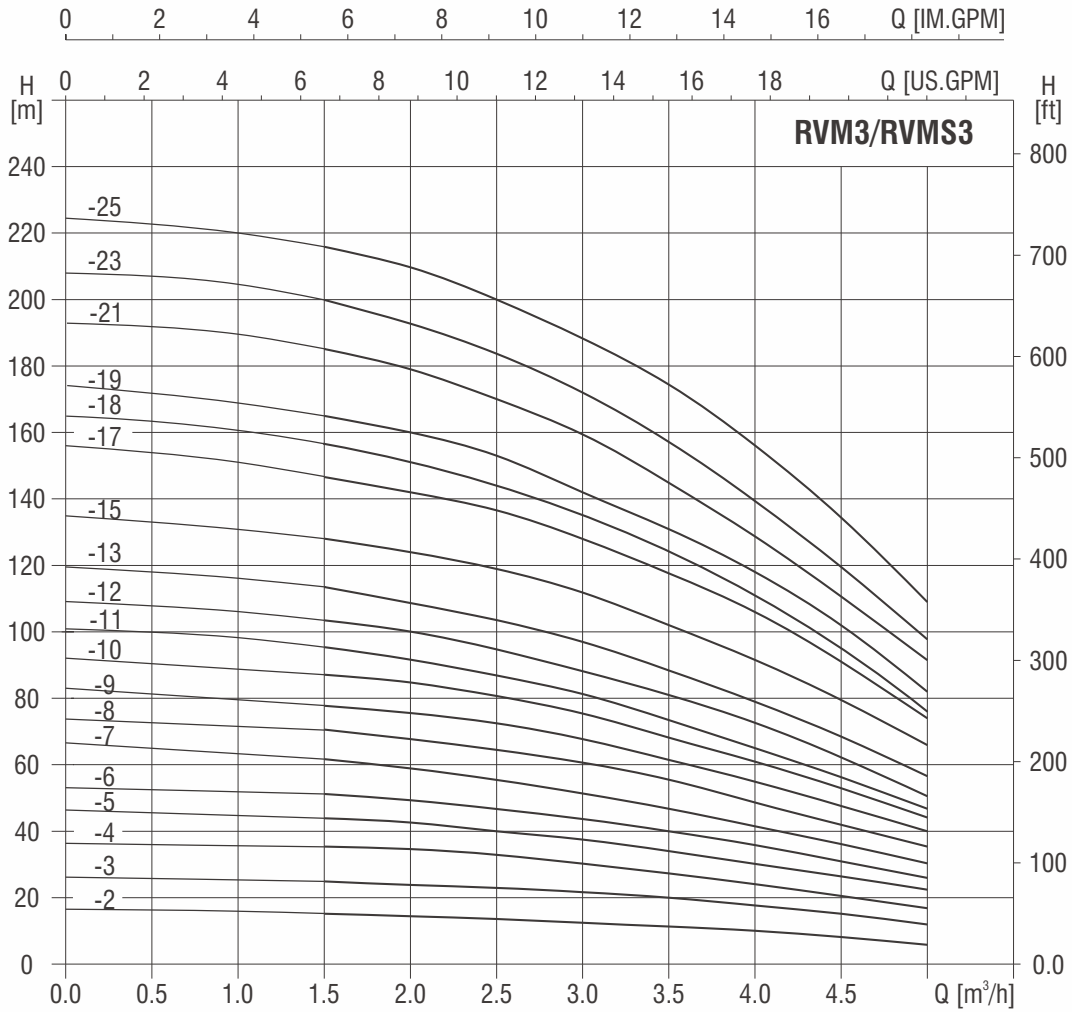

PERFORMANCE TABLE

MODEL	DRIVING MOTOR		FRAME	Q(m ³ /h)	1.5	2	2.5	3	3.5	4	4.5	5
	(kW)	(hp)										
RVM3-2	0.37	0.5	56C	H[m]	17.5	16	15	14	13	11	9	8
RVM3-3	0.55	0.75	56C		26.5	25	24	23	20	18	15	12
RVM3-4	0.55	0.75	56C		35	34	32	30	27	25	20	17
RVM3-5	0.75	1	56C		44	42	40	38	33	31	26	23
RVM3-6	1.1	1.5	56C		51	50	48	45	40	37	32	27
RVM3-7	1.1	1.5	56C		61	59	56	52	46	43	38	31
RVM3-8	1.1	1.5	56C		70	67	64	61	53	49	44	35
RVM3-9	1.5	2	56C		78	77	72	68	60	56	50	40
RVM3-10	1.5	2	56C		87	84	81	76	68	63	55	44
RVM3-11	1.5	2	56C		96	92	87	82	74	69	59	48
RVM3-12	2.2	3	182TC		104	100	96	90	79	73	63	52
RVM3-13	2.2	3	182TC		112	109	104	98	86	80	69	57
RVM3-15	2.2	3	182TC		129	126	120	112	99	93	81	65
RVM3-17	2.2	3	182TC		147	143	137	128	114	106	91	74
RVM3-18	2.2	3	182TC		156	152	145	135	120	112	96	78
RVM3-19	3.7	5	184TC		165	160	153	142	126	118	102	82
RVM3-21	3.7	5	184TC		183	178	170	160	141	129	112	91
RVM3-23	3.7	5	184TC		200	194	185	174	154	142	122	98
RVM3-25	3.7	5	184TC		217	211	202	187	167	154	134	108

PUMP DIMENSIONS

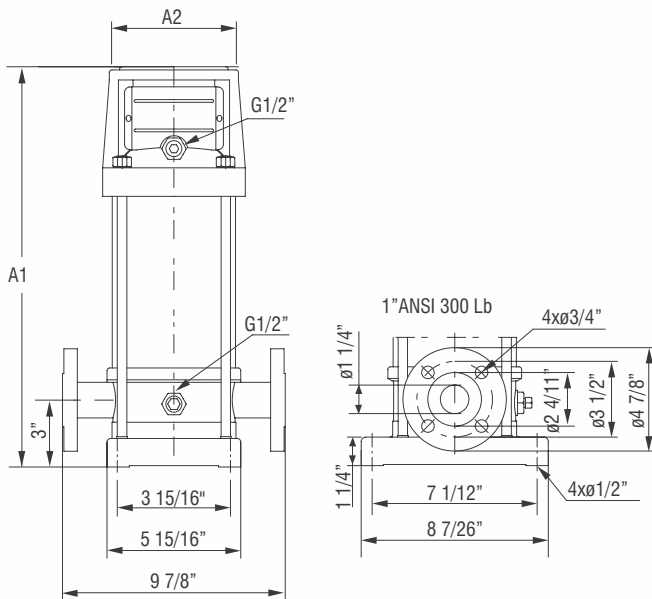

SIZE AND WEIGHT

MODEL	SIZE (INCH)		WEIGHT (lbs)
	A1	A2	
RVM3-2	11 1/4	6 1/2	34
RVM3-3	12	6 1/2	35
RVM3-4	12 11/16	6 1/2	36
RVM3-5	13 3/8	6 1/2	37
RVM3-6	14 1/8	6 1/2	39
RVM3-7	14 13/16	6 1/2	40
RVM3-8	15 9/16	6 1/2	41
RVM3-9	16 1/4	6 1/2	42
RVM3-10	16 15/16	6 1/2	43
RVM3-11	17 11/16	6 1/2	44
RVM3-12	18 11/16	8 7/8	50
RVM3-13	19 3/8	8 7/8	51
RVM3-15	20 13/16	8 7/8	53
RVM3-17	22 1/4	8 7/8	54
RVM3-18	22 15/16	8 7/8	55
RVM3-19	23 5/8	8 7/8	56
RVMS3-21	25 1/16	8 7/8	57
RVMS3-23	26 1/2	8 7/8	60
RVMS3-25	27 7/8	8 7/8	62

PERFORMANCE CURVE

RVM/RVMS4, 60HZ

ISO9906 Annex A

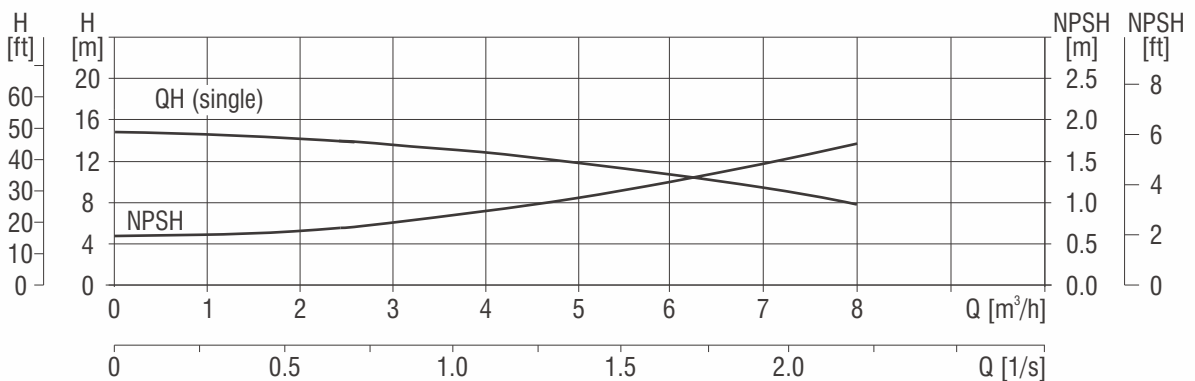
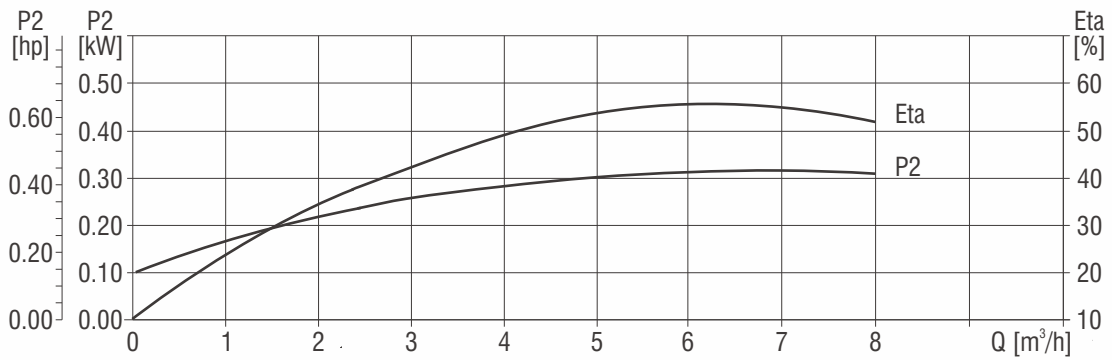
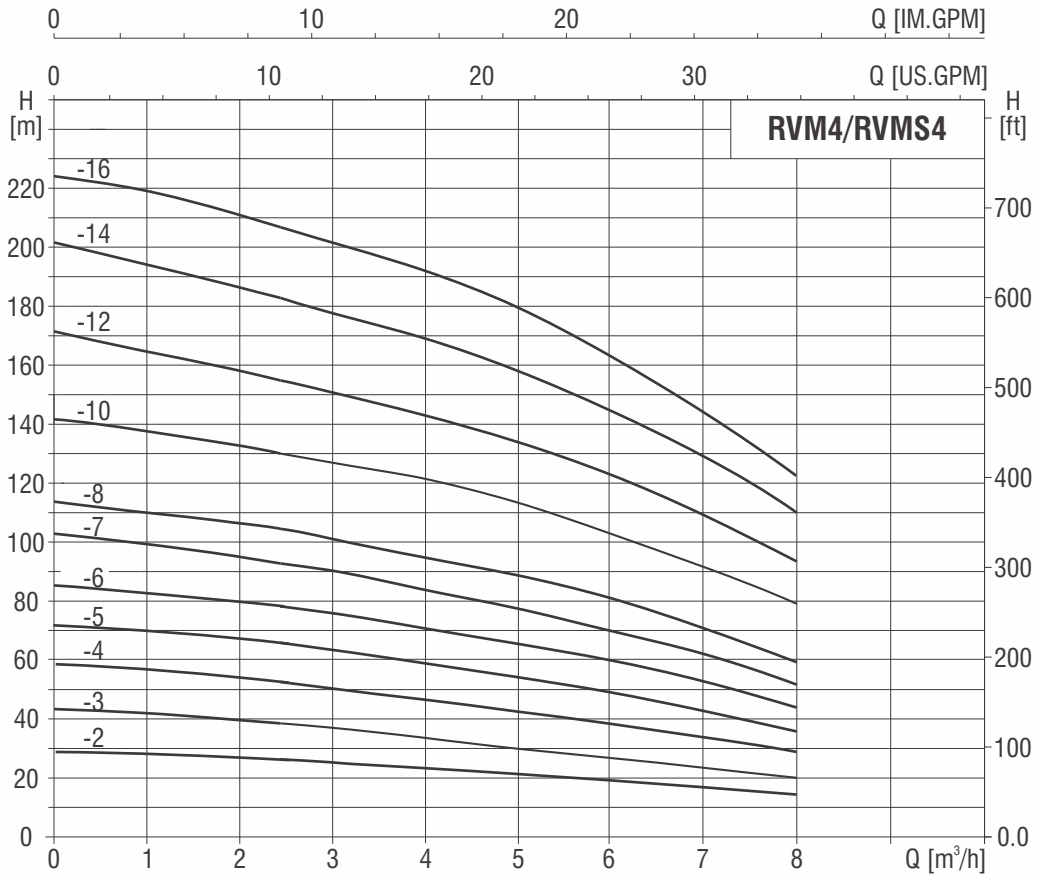

PERFORMANCE TABLE

MODEL	DRIVING MOTOR		FRAME	Q(m ³ /h)	2.5	3	4	5	6	7	8
	(kW)	(hp)									
RVM4-2	0.75	1	56C	H[m]	26	25	23	21	19	16	14
RVM4-3	1.1	1.5	56C		39	38	36	32	28	24	21
RVM4-4	1.5	2	56C		52	50	48	44	38	35	31
RVM4-5	2.2	3	182TC		65	62	60	55	49	44	39
RVM4-6	2.2	3	182TC		78	75	72	67	59	54	47
RVM4-7	3.7	5	184TC		92	88	84	78	69	62	55
RVM4-8	3.7	5	184TC		104	100	95	90	79	72	63
RVM4-10	3.7	5	184TC		130	125	120	113	102	90	80
RVM4-12	5.5	7.5	213TC		156	150	145	136	122	109	96
RVM4-14	5.5	7.5	213TC		182	176	170	159	145	129	112
RVM4-16	5.5	7.5	213TC		207	201	196	183	165	146	128

PUMP DIMENSIONS

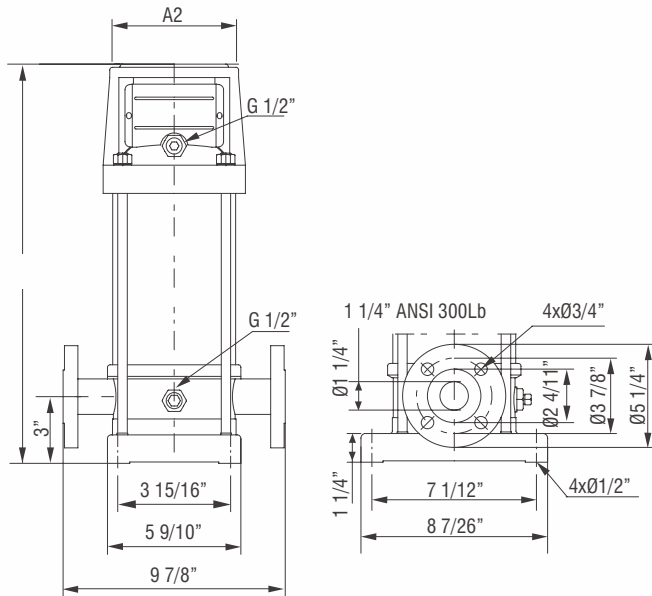

SIZE AND WEIGHT

MODEL	SIZE (INCH)		WEIGHT (lbs)
	A1	A2	
RVM4-2	12	6 1/2	37
RVM4-3	13 1/16	6 1/2	39
RVM4-4	14 1/8	6 1/2	40
RVM4-5	15 7/16	8 7/8	46
RVM4-6	16 9/16	8 7/8	47
RVM4-7	17 5/8	8 7/8	49
RVM4-8	18 11/16	8 7/8	50
RVM4-10	20 13/16	8 7/8	51
RVM4-12	23 7/16	8 7/8	55
RVM4-14	25 9/16	8 7/8	57
RVM4-16	27 11/16	8 7/8	60

PERFORMANCE CURVE

RVM/RVMS8, 60HZ

ISO9906 Annex A

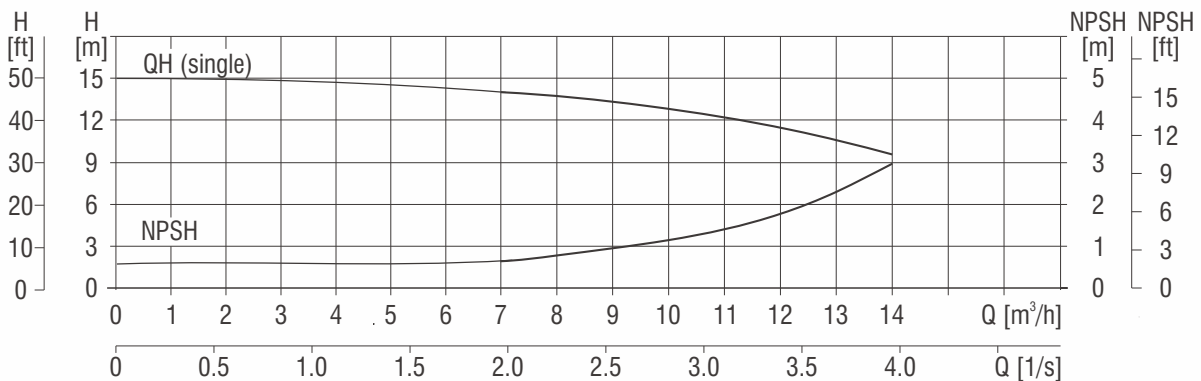
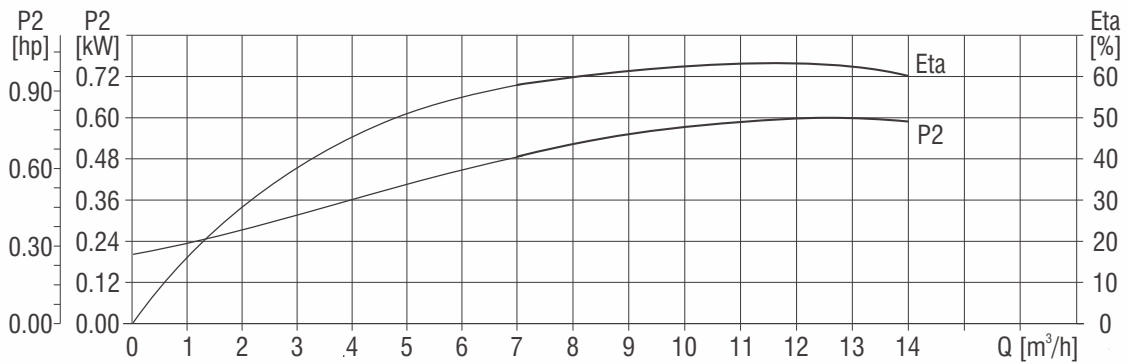
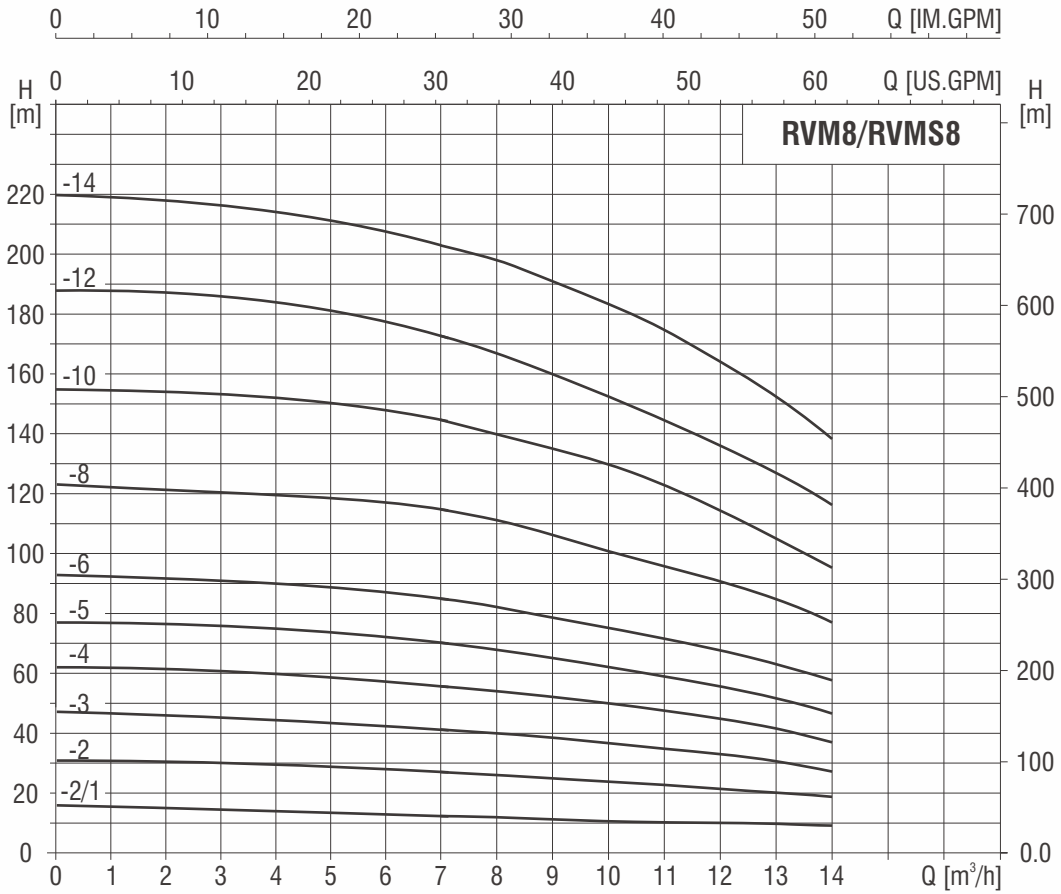

PERFORMANCE TABLE

MODEL	DRIVING MOTOR		FRAME	Q(m ³ /h)	7	8	9	10	11	12	13	14
	(kW)	(hp)										
RVM8-2/1	0.75	1	56C	H[m]	13	12	11.5	11	10.5	10	9.5	9
RVM8-2	1.5	2	56C		27	26	25	24	23	22	20	18
RVM8-3	2.2	3	182TC		41	40	38	37	35	33	30	28
RVM8-4	3.7	5	184TC		55	54	52	50	47	45	41	38
RVM8-5	3.7	5	184TC		70	68	65	63	59	56	52	47
RVM8-6	3.7	5	184TC		85	82	78	76	72	68	62	57
RVM8-8	5.5	7.5	213TC		115	110	105	101	97	91	84	75
RVM8-10	7.5	10	215TC		145	140	132	126	122	115	105	95
RVM8-12	7.5	10	215TC		173	167	160	152	147	132	125	115
RVM8-14	11	15	254TC		202	195	188	179	174	163	147	135

PUMP DIMENSIONS

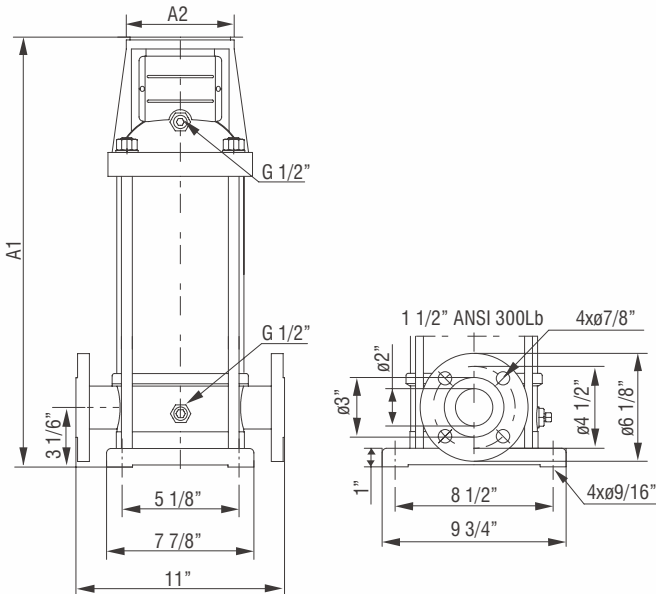

SIZE AND WEIGHT

MODEL	SIZE (INCH)		WEIGHT (lbs)
	A1	A2	
RVM8-2/1	14 4/9	6 1/2	57
RVM8-2	14 4/9	6 1/2	57
RVM8-3	16 1/16	8 7/8	65
RVM8-4	17 1/4	8 7/8	66
RVM8-5	18 3/7	8 7/8	67
RVM8-6	19 3/5	8 7/8	68
RVM8-8	22 11/25	8 7/8	82
RVM8-10	24 4/5	8 7/8	84
RVM8-12	27 1/6	8 7/8	86
RVM8-14	32 13/25	8 7/8	95

PERFORMANCE CURVE

RVM/RVMS16, 60HZ

ISO9906 Annex A

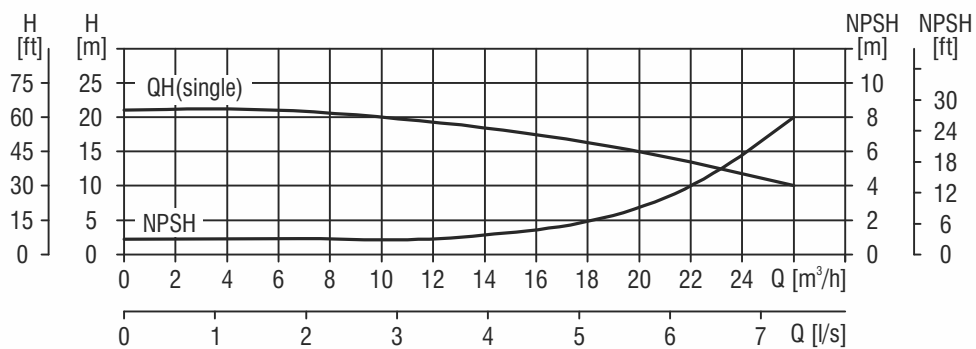
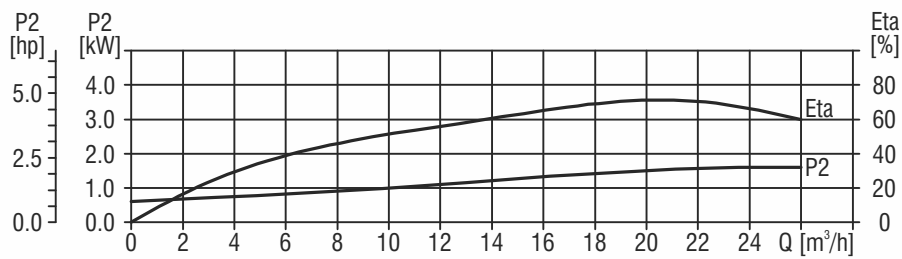
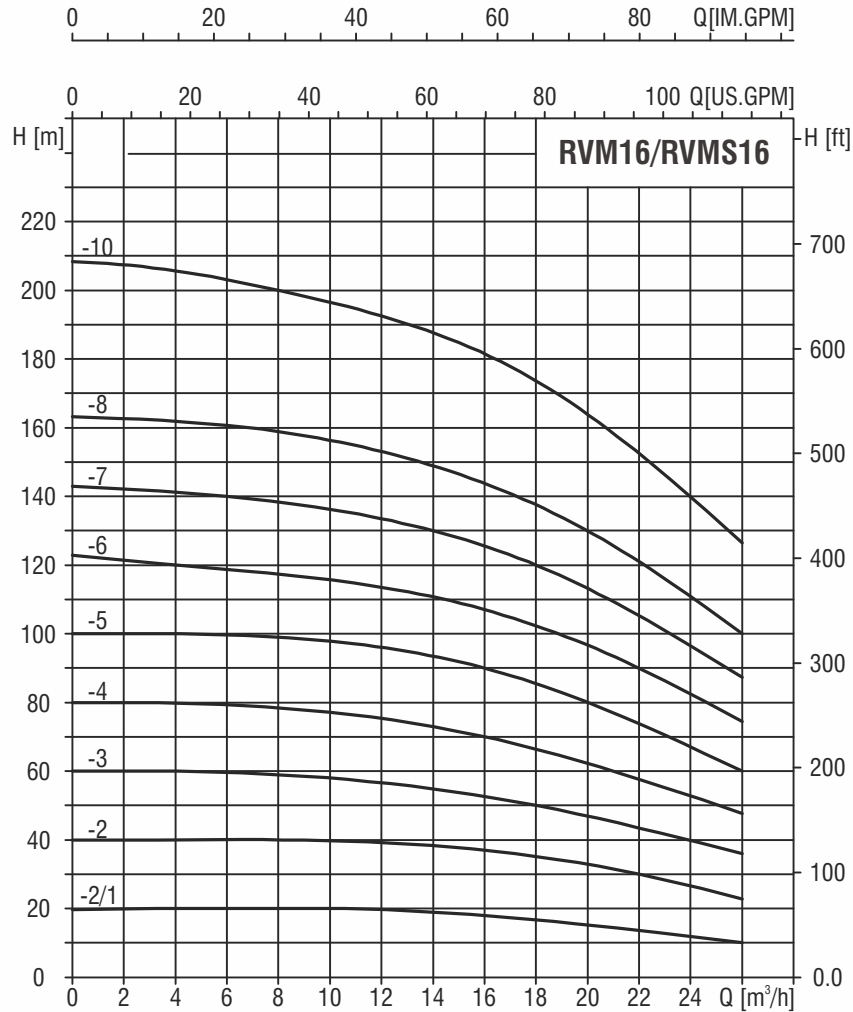

PERFORMANCE TABLE

MODEL	DRIVING MOTOR		FRAME	Q(m ³ /h)	10	12	14	16	18	20	22	24	26
	(kW)	(hp)											
RVM16-2/1	2.5	3	182TC	H[m]	19	18.5	18	17	16	15	14	13	11
RVM16-2	3.7	5	184TC		38	37	36	35	34	32	30	27	24
RVM16-3	5.5	7.5	213TC		57	56	55	54	51	48	45	40	36
RVM16-4	7.5	10	215TC		76	75	73	72	68	64	60	54	49
RVM16-5	11	15	254TC		96	94	92	90	85	80	75	68	62
RVM16-6	11	15	254TC		115	113	111	108	102	96	91	82	75
RVM16-7	15	20	256TC		135	132	129	126	119	113	106	96	88
RVM16-8	15	20	256TC		155	152	148	144	137	130	122	111	101
RVM16-10	18.5	25	284TSC		197	192	187	181	174	165	153	139	127

PUMP DIMENSIONS

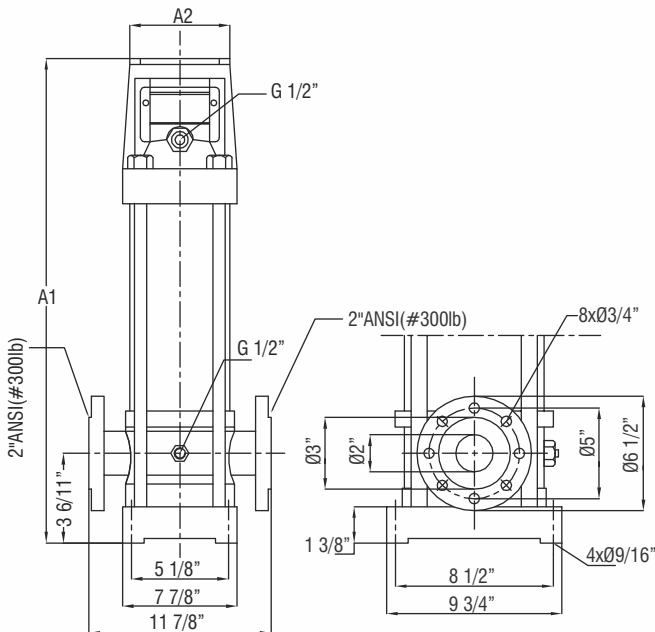

SIZE AND WEIGHT

MODEL	SIZE (INCH)		WEIGHT (lbs)
	A1	A2	
RVM16-2/1	16 11/24	8 7/8	71
RVM16-2	16 11/24	8 7/8	71
RVM16-3	18 7/10	8 7/8	73
RVM16-4	20 8/17	8 7/8	75
RVM16-5	25 4/17	8 7/8	84
RVM16-6	27	8 7/8	86
RVM16-7	28 15/19	8 7/8	88
RVM16-8	30 5/9	8 7/8	93
RVM16-10	33 9/26	11 1/32	101

PERFORMANCE CURVE

RVM/RVMS20, 60HZ

ISO9906 Annex A

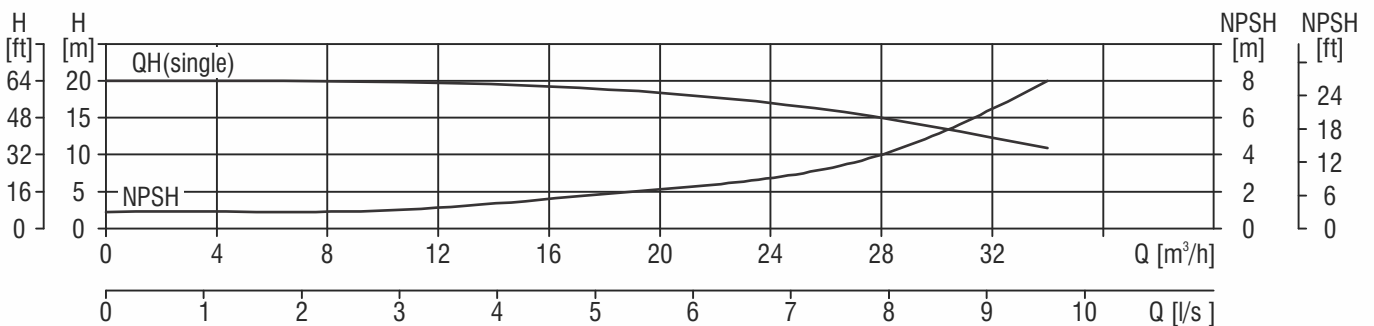
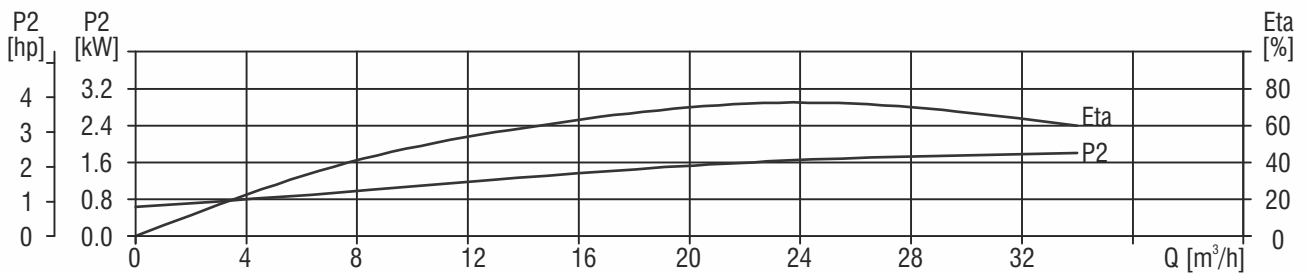
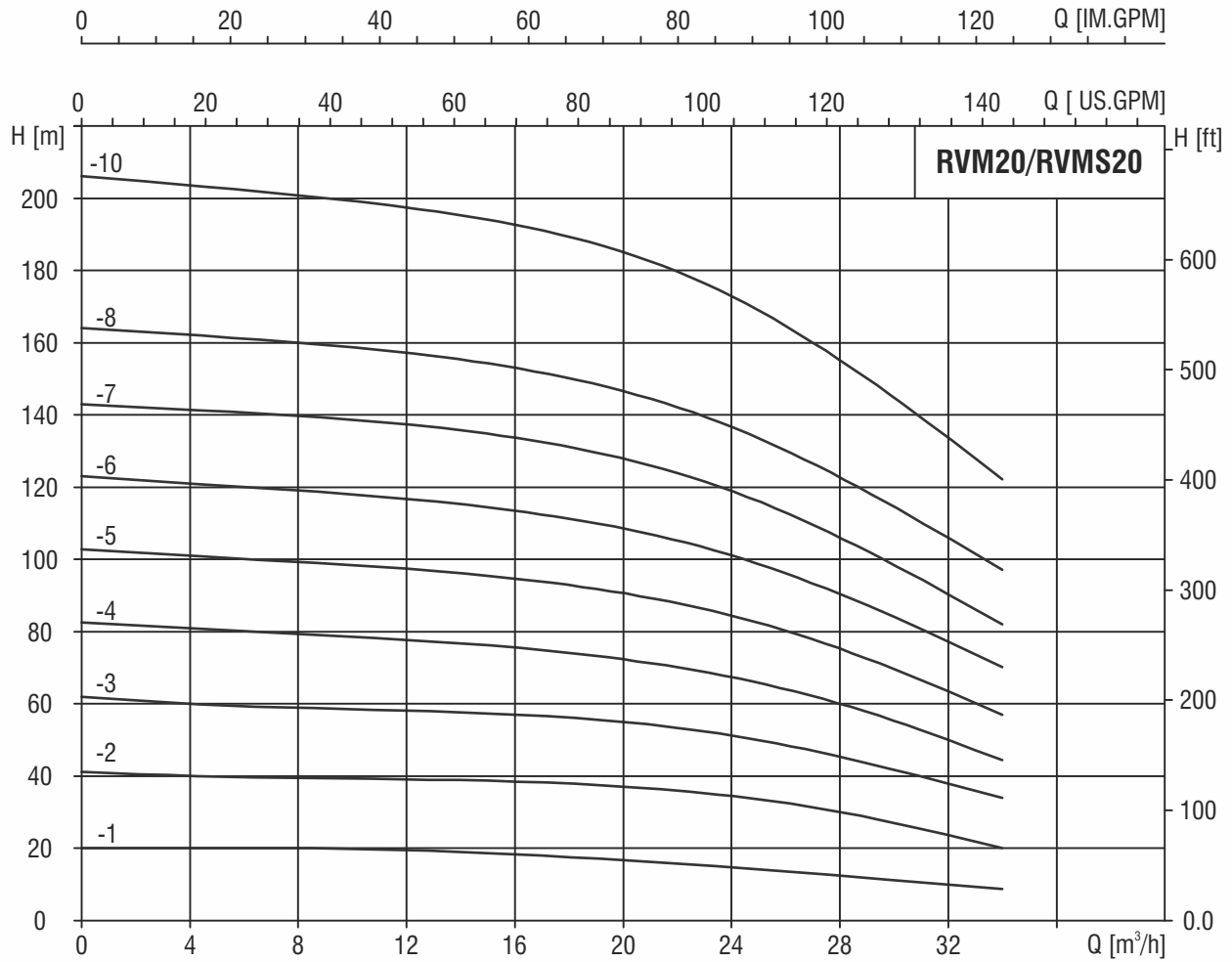

PERFORMANCE TABLE

MODEL	DRIVING MOTOR		FRAME	Q(m ³ /h)	12	16	20	24	28	32	34
	(kW)	(hp)									
RVM20-1	2.2	3	182TC	H[m]	19	18	17	15	13	10	8.5
RVM20-2	3.7	5	184TC		38	37	35	32	29	24	21
RVM20-3	5.5	7.5	213TC		58	56	53	50	45	38	33
RVM20-4	7.5	10	215TC		78	75	72	67	60	51	45
RVM20-5	11	15	254TC		98	94	90	85	75	64	57
RVM20-6	11	15	254TC		118	113	108	102	91	77	70
RVM20-7	15	20	256TC		138	133	127	119	107	91	83
RVM20-8	15	20	256TC		158	153	146	137	123	105	96
RVM20-10	18.5	25	284TSC		198	193	185	172	155	133	122

PUMP DIMENSIONS

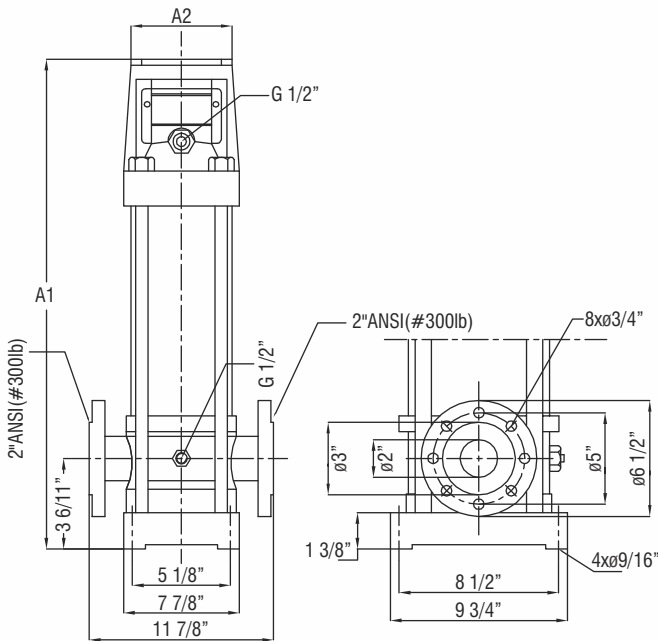

SIZE AND WEIGHT

MODEL	SIZE (INCH)		WEIGHT (lbs)
	A1	A2	
RVM20-1	16 11/24	8 7/8	73
RVM20-2	16 11/24	8 7/8	73
RVM20-3	18 7/10	8 7/8	75
RVM20-4	20 4/9	8 7/8	77
RVM20-5	25 4/17	8 7/8	86
RVM20-6	27	8 7/8	88
RVM20-7	28 15/19	8 7/8	90
RVM20-8	30 5/9	8 7/8	95
RVM20-10	33 9/26	11 1/32	104

PERFORMANCE CURVE

RVM/RVMS32, 60HZ

ISO9906 Annex A

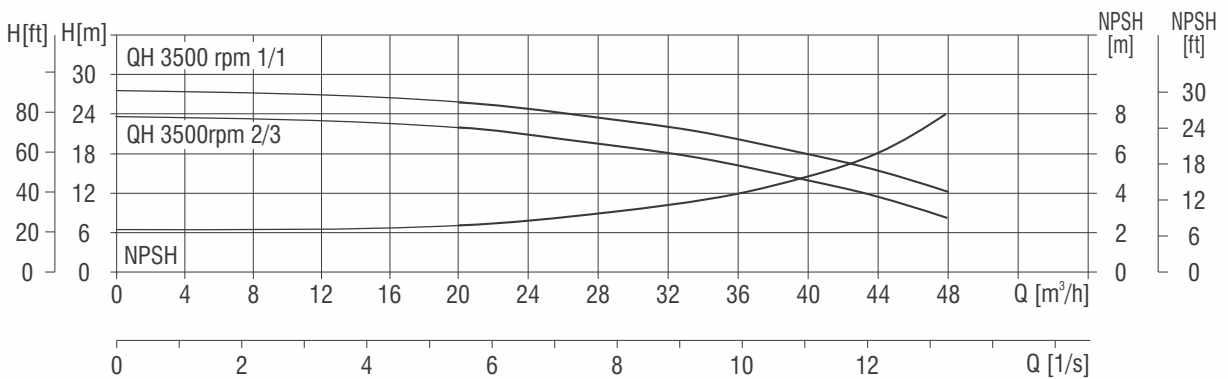
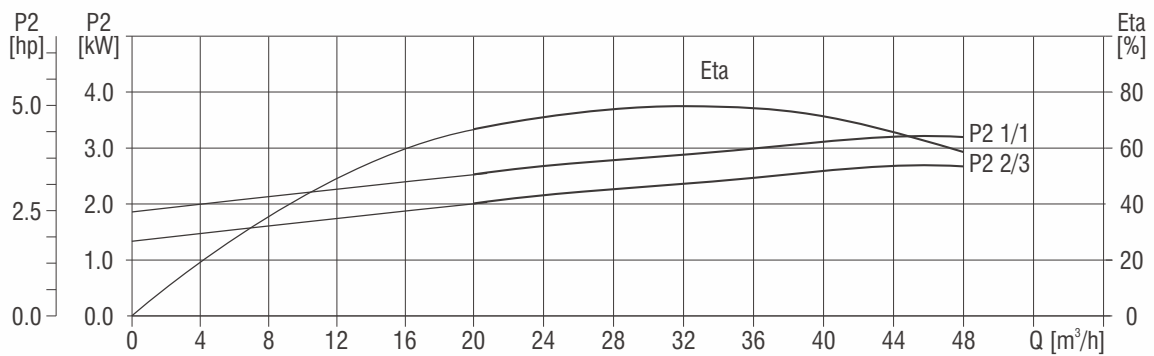
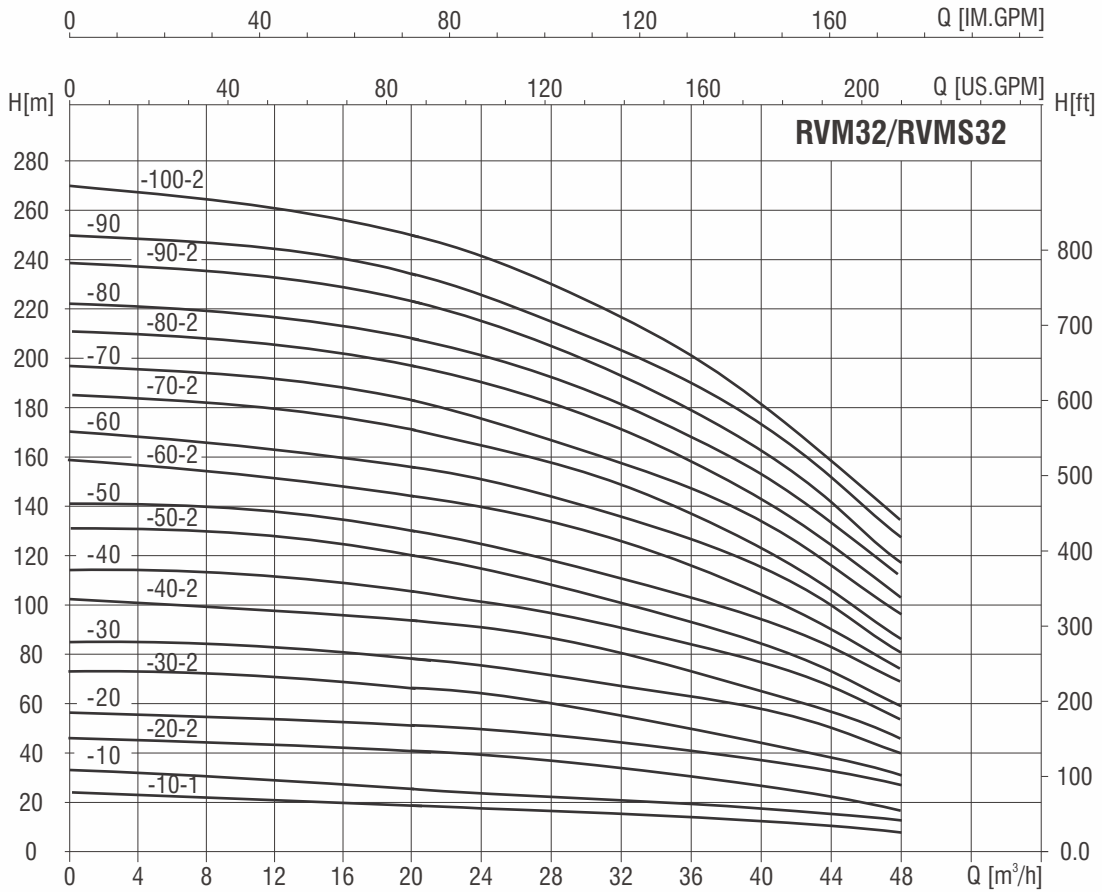

PERFORMANCE TABLE

MODEL	DRIVING MOTOR		FRAME	Q(m ³ /h)	20	24	28	32	36	40	44	48
	(kW)	(hp)										
RVM32-10-1	2.2	3	182TC	H[m]	20	19	18	17	15	13	10	7
RVM32-10	3.7	5	184TC		26	25	24	23	21	19	17	14
RVM32-20-2	5.5	7.5	213TC		41	40	38	35	31	27	22	17
RVM32-20	7.5	10	215TC		52	50	48	45	41	37	33	27
RVM32-30-2	7.5	10	215TC		67	64	61	57	52	46	39	31
RVM32-30	11	15	254TC		78	75	71	67	62	56	50	40
RVM32-40-2	11	15	254TC		94	91	87	81	73	65	56	45
RVM32-40	15	20	256TC		104	101	96	91	83	75	66	55
RVM32-50-2	15	20	256TC		119	115	109	102	94	84	73	59
RVM32-50	15	20	256TC		130	125	119	112	104	94	83	69
RVM32-60-2	18.5	25	284TC		145	140	134	126	116	104	90	74
RVM32-60	18.5	25	284TC		155	150	144	136	126	114	100	81
RVM32-70-2	22	30	286TC		172	166	158	149	137	123	106	86
RVM32-70	22	30	286TC		182	176	168	159	148	133	118	97
RVM32-80-2	22	30	286TC		196	190	182	172	159	143	124	102
RVM32-80	30	40	324TC		208	201	192	181	167	152	132	111
RVM32-90-2	30	40	324TC		223	216	206	194	179	162	142	117
RVM32-90	30	40	324TC		234	226	216	204	189	172	152	127
RVM32-100-2	30	40	324TC		248	241	231	217	201	181	159	133

PUMP DIMENSIONS

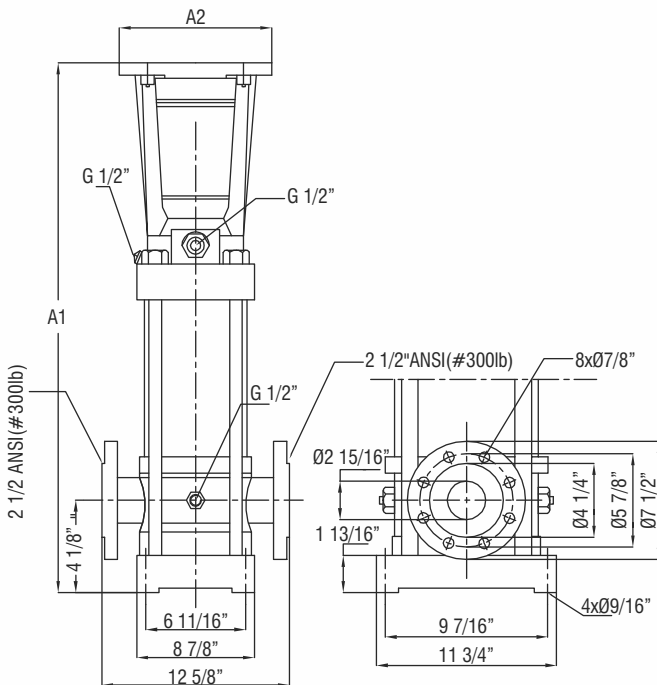

SIZE AND WEIGHT

MODEL	SIZE (INCH)		WEIGHT (lbs)
	A1	A2	
RVM32-10-1	20 3/25	8 7/8	93
RVM32-10	20 3/25	8 7/8	93
RVM32-20-2	22 7/8	8 7/8	101
RVM32-20	22 7/8	8 7/8	101
RVM32-30-2	25 5/8	8 7/8	110
RVM32-30	29 2/15	8 7/8	128
RVM32-40-2	31 8/9	8 7/8	137
RVM32-40	31 8/9	8 7/8	137
RVM32-50-2	34 9/14	8 7/8	146
RVM32-50	34 9/14	8 7/8	139
RVM32-60-2	33 6/7	11 1/32	148
RVM32-60	33 6/7	11 1/32	148
RVM32-70-2	37 3/8	11 1/32	157
RVM32-70	37 3/8	11 1/32	157
RVM32-80-2	42 1/8	11 1/32	165
RVM32-80	42 11/12	13 7/12	179
RVM32-90-2	42 11/12	13 7/12	187
RVM32-90	42 11/12	13 7/12	187
RVM32-100-2	48 3/7	13 7/12	196

PERFORMANCE CURVE

RVM/RVMS42, 60HZ

ISO9906 Annex A

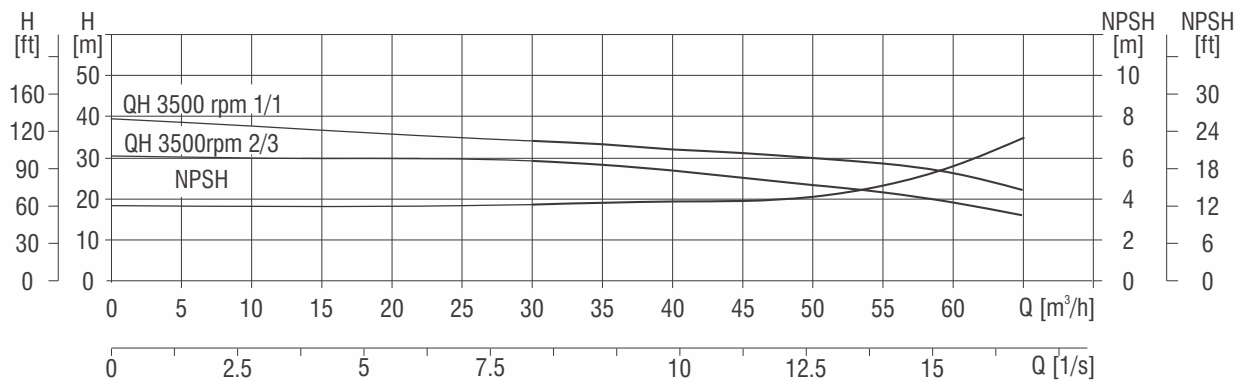
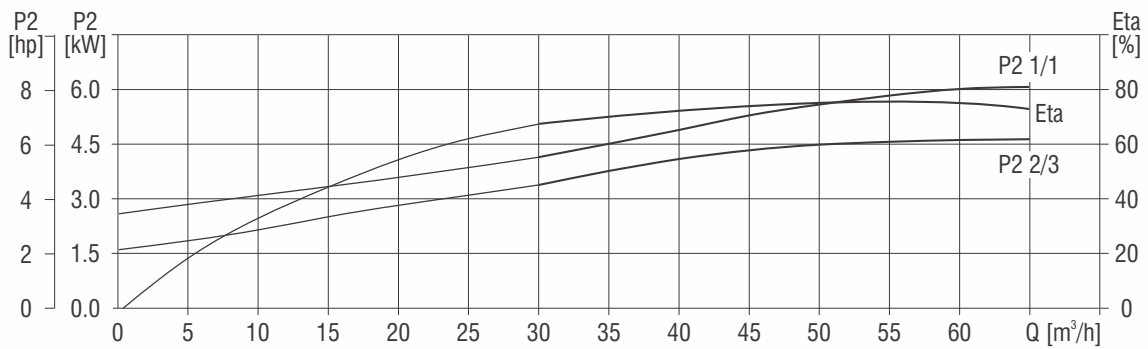
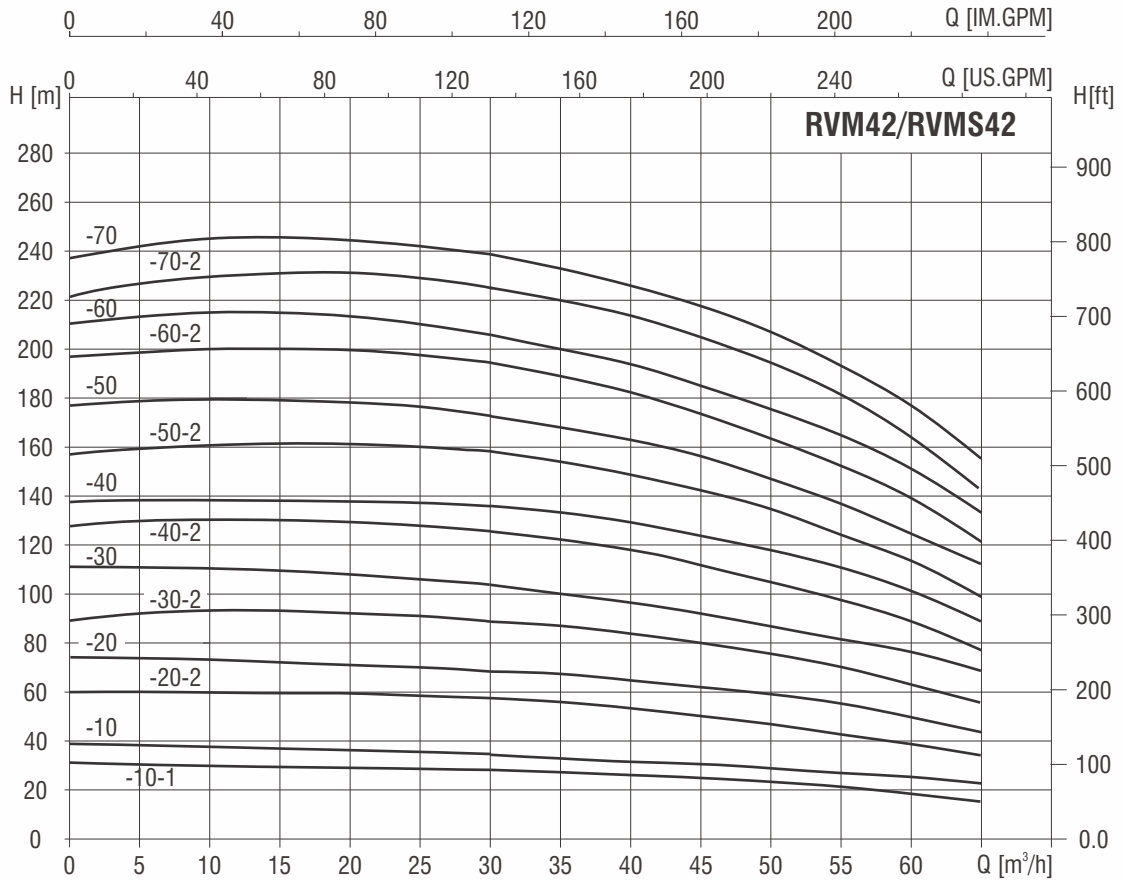

PERFORMANCE TABLE

MODEL	DRIVING MOTOR		FRAME	Q(m ³ /h)	30	35	40	42	45	50	55	60	65
	(kW)	(hp)											
RVM42-10-1	5.5	7.5	213TC	H[m]	29	28	27	26	25	23	21	19	16
RVM42-10	7.5	10	215TC		34	33	32	31.5	30	29	27	25	22
RVM42-20-2	11	15	254TC		57	55	53	52	49	46	43	38	33
RVM42-20	15	20	256TC		69	67	65	63	61	59	55	50	44
RVM42-30-2	18.5	25	284TSC		90	88	85	83	80	75	72	63	55
RVM42-30	18.5	25	284TSC		102	100	97	95	92	88	82	76	68
RVM42-40-2	22	30	286TSC		125	121	118	115	112	105	98	89	78
RVM42-40	30	40	324TSC		136	133	129	126	123	117	112	102	89
RVM42-50-2	30	40	324TSC		159	154	149	146	142	134	121	115	99
RVM42-50	30	40	324TSC		171	166	161	158	154	145	138	126	112
RVM42-60-2	37	50	326TSC		194	188	182	178	173	163	155	139	122
RVM42-60	37	50	326TSC		205	200	193	190	186	176	166	152	134
RVM42-70-2	45	60	364TSC		227	220	213	210	205	193	182	165	144
RVM42-70	45	60	364TSC		239	232	226	221	216	204	194	178	157

PUMP DIMENSIONS

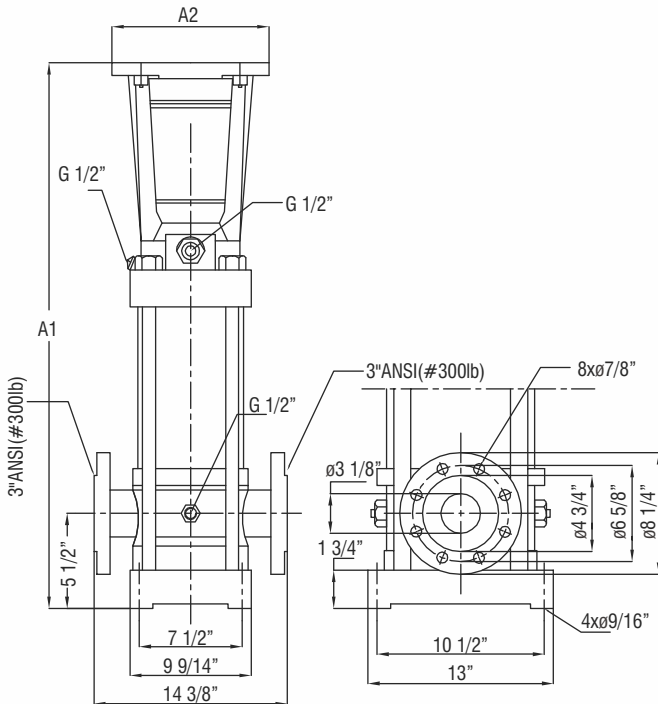

SIZE AND WEIGHT

MODEL	SIZE (INCH)		WEIGHT (lbs)
	A1	A2	
RVM42-10-1	22 8/25	8 7/8	137
RVM42-10	22 8/25	8 7/8	137
RVM42-20-2	29 1/20	8 7/8	163
RVM42-20	29 1/20	8 7/8	163
RVM42-30-2	31 2/5	11 1/32	165
RVM42-30	31 2/5	11 1/32	165
RVM42-40-2	34 9/16	11 1/32	174
RVM42-40	35 5/14	13 7/12	190
RVM42-50-2	38 1/2	13 7/12	198
RVM42-50	38 1/2	13 7/12	198
RVM42-60-2	41 2/3	13 7/12	207
RVM42-60	41 2/3	13 7/12	207
RVM42-70-2	44 2/5	15 11/20	234
RVM42-70	44 2/5	15 11/20	234

PERFORMANCE CURVE

RVM/RVMS65, 60HZ

ISO9906 Annex A

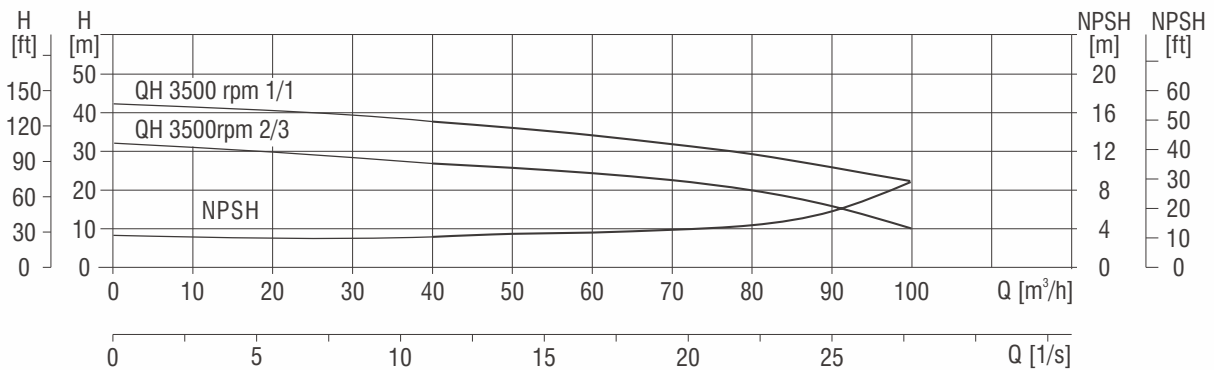
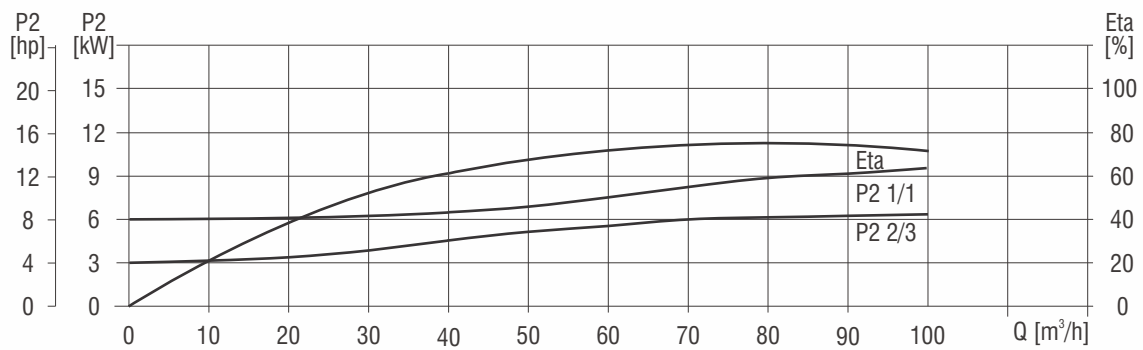
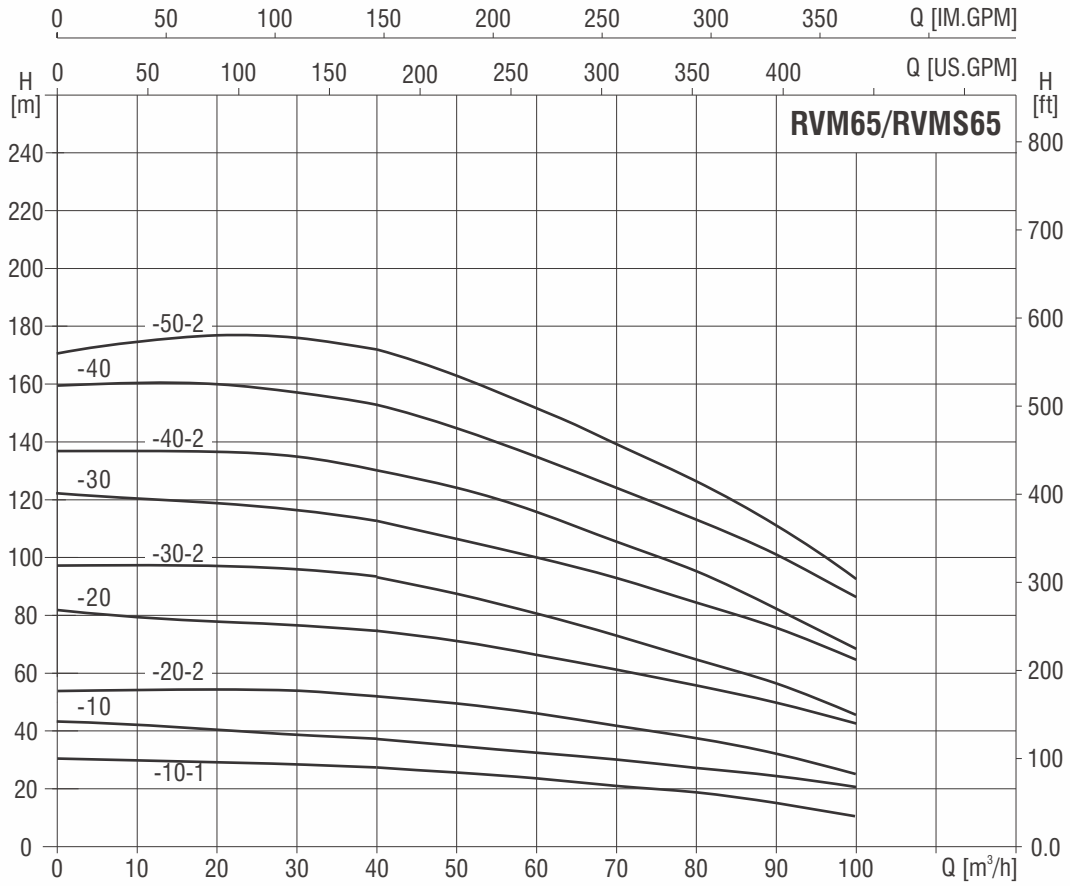

PERFORMANCE TABLE

MODEL	DRIVING MOTOR		FRAME	Q(m ³ /h)	40	50	60	65	70	80	90	100
	(kW)	(hp)										
RVM65-10-1	7.5	10	215TC	H[m]	26	25	23	22	21	18	14	10
RVM65-10	11	15	254TC		37	35	33	32	31	28	24	21
RVM65-20-2	15	20	256TC		53	50	47	44	42	37	31	23
RVM65-20	22	30	286TSC		74	72	67	64	62	57	51	42
RVM65-30-2	22	30	286TSC		93	88	80	76	72	65	56	45
RVM65-30	30	40	324TSC		112	108	100	96	93	86	77	65
RVM65-40-2	30	40	324TSC		130	124	115	110	103	94	83	66
RVM65-40	37	50	326TSC		152	144	135	130	123	114	102	86
RVM65-50-2	45	60	364TSC		172	162	151	144	137	126	112	91

PUMP DIMENSIONS

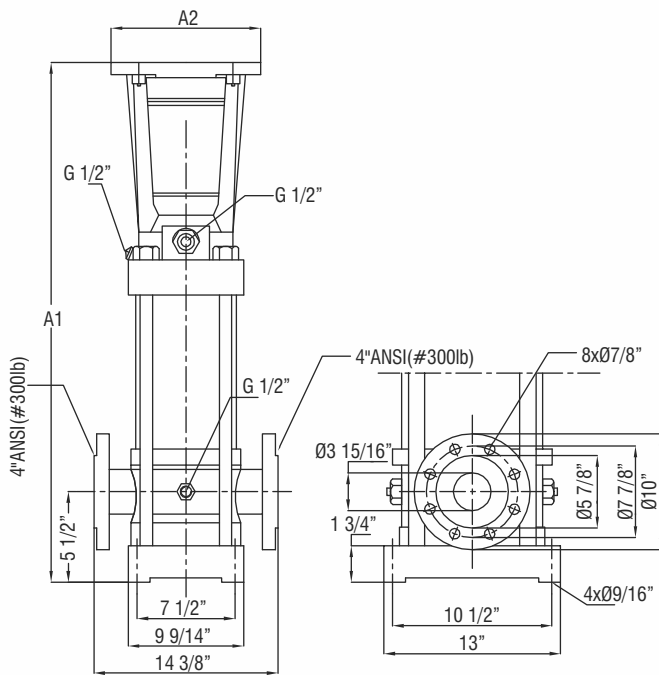

SIZE AND WEIGHT

MODEL	SIZE (INCH)		WEIGHT (lbs)
	A1	A2	
RVM65-10-1	22 8/25	8 7/8	139
RVM65-10	26 1/42	8 7/8	157
RVM65-20-2	29 5/17	8 7/8	168
RVM65-20	28 1/2	11 1/32	161
RVM65-30-2	31 11/15	11 1/32	172
RVM65-30	32 1/2	13 7/12	187
RVM65-40-2	35 10/13	13 7/12	198
RVM65-40	35 15/19	13 7/12	214
RVM65-50-2	38 5/8	15 11/20	225

PERFORMANCE CURVE

RVM/RVMS85, 60HZ

ISO9906 Annex A

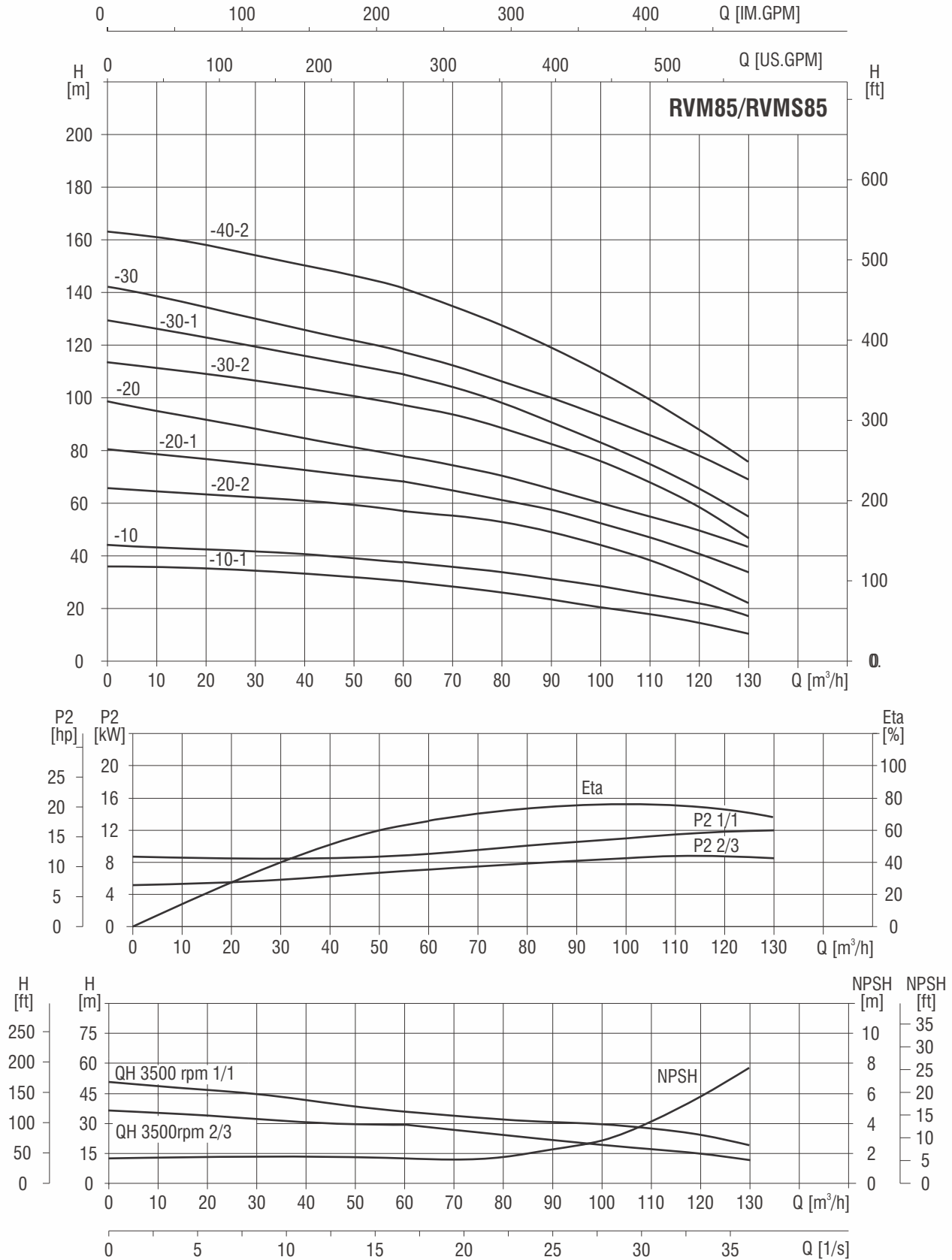

PERFORMANCE TABLE

MODEL	DRIVING MOTOR		FRAME	Q(m ³ /h)	60	70	80	85	90	100	110	120	130
	(kW)	(hp)			H[m]								
RVM85-10-1	11	15	254TC	H[m]	31	27	25	24	23	21	18	14	9
RVM85-10	15	20	256TC		36	35	33	31	30	29	26	23	18
RVM85-20-2	18.5	25	284TSC		59	57	54	51	48	44	39	32	22
RVM85-20-1	22	30	286TSC		67	65	62	59	57	51	48	41	33
RVM85-20	30	40	324TSC		76	73	69	66	64	60	56	52	44
RVM85-30-2	37	50	326TSC		98	94	88	85	82	75	69	59	46
RVM85-20-1	37	50	326TSC		108	104	98	94	90	83	78	69	56
RVM85-20	45	60	364TSC		116	111	105	102	97	93	88	79	69
RVM85-40-2	45	60	364TSC		141	135	128	124	118	109	102	89	72

PUMP DIMENSIONS

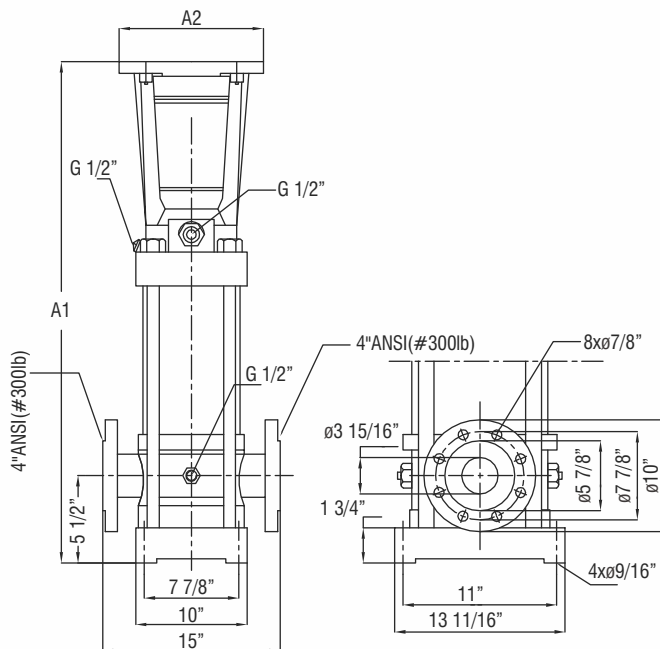

SIZE AND WEIGHT

MODEL	SIZE (INCH)		WEIGHT (lbs)
	A1	A2	
RVM85-10-1	22 2/3	8 7/8	163
RVM85-10	22 2/3	8 7/8	163
RVM85-20-2	29 1/4	11 1/32	168
RVM85-20-1	29 1/4	11 1/32	168
RVM85-20	30 1/25	13 7/12	187
RVM85-30-2	33 2/3	13 7/12	202
RVM85-20-1	33 2/3	13 7/12	202
RVM85-20	33 4/15	15 11/20	220
RVM85-40-2	36 8/9	15 11/20	234

ROTECH'S OTHER PRODUCTS

- ▶ DNJ Series End Suction Close Coupled Pumps
- ▶ DN Series End Suction Frame Mounted Pumps
- ▶ 1196 Series ANSI Chemical Process Pumps
- ▶ 1196LF series Low Flow ANSI Pumps
- ▶ 1796 Series ANSI Self Priming Pumps
- ▶ RCP Series End Suction Pumps
- ▶ RST Series Stainless Stamped End Suction Pumps
- ▶ RVMS Series Vertical Multistage Centrifugal Pumps
- ▶ RVI80 Series Vertical Inline Pumps
- ▶ SPT/SPU Series Self Priming Trash Pumps
- ▶ SCP/SFP Series Self Priming Pumps
- ▶ S100 Series Sanitary Centrifugal Pumps
- ▶ L100 Series Lobe Pumps
- ▶ RDSL Series Horizontal Multistage Centrifugal Pumps
- ▶ 3100 Series NPT & 5100 Series Flanged Ball Check Valves
- ▶ Various Mechanical Seals

Apart from the listed above,
we offer an array of other products too.
Contact us for further details.



"A Trusted Partner in Pump Solutions"

1320 Britannia Road East
Mississauga, Ontario, Canada. L4W 1C8

Phone: (905) 461-9617 | Fax: (905) 461-9618
Toll Free: 1-866-217-PUMP (7867)
Email: sales@rotechpumps.com | www.rotechpumps.com