

— THE —
**STRONG,
SILENT**
— TYPE —



SILENSOR™

***INTRODUCING DAVEY'S ALL NEW,
SUPER-QUIET POOL PUMP***

DEPEND ON
DAVEY

WATER PRODUCTS

SILENSOR™ ... DAVEY'S ALL N

The Silensor represents some of the biggest breakthroughs in Davey pump technology for many years. Made in Australia, for Australian conditions, the Silensor has been specifically designed and engineered to combat the age-old pool pump problem...excessive noise. As the name suggests, Davey's Silensor truly heralds a quiet pool pump revolution. And, as you've come to expect from Davey, the all new Silensor is extremely dependable. Solid construction and superior quality control in manufacture ensure your new Silensor will quietly go about its business day after day, year after year.

NEW

SUPER-QUIET

Water-Silenced - Silensor's water-silenced motor uses a small water flow around the stainless steel, corrosion proof motor shell. This captures noise and vibrations, allowing the Silensor's ultra quiet operation. Plus, the Silensor motor does not need a fan... a big contributor to noise. The very low operating noise levels of Silensor makes it ideal for backyard operation, close to neighbours, where quietness is very important.



NEW

LONG LASTING

UV Stabilised - Silensor's advanced design utilises high performance UV stabilised polymers for outdoor installation. The design does away with highly corrodible metals such as aluminium and mild steel in exposed areas, making Silensor the ideal choice for modern salt water pools. Bolts and screws that can rust and render a pump unserviceable have also been replaced with easily operated clamp rings, ensuring simple maintenance.



NEW

COST SAVING

Efficient Design - Silensor has been designed using the latest computational fluid dynamics to move water efficiently. The water passages inside the pump have been refined to such an extent that Silensor is up to 15% more efficient than most standard pool pumps now available. That can mean a saving of up to \$100 a year in energy costs, year after year.

Off Peak Running - Quietness may also allow operation of pumps late at night when energy costs are much lower (off peak). The savings on running costs could pay for your NEW Silensor pump in the long run.

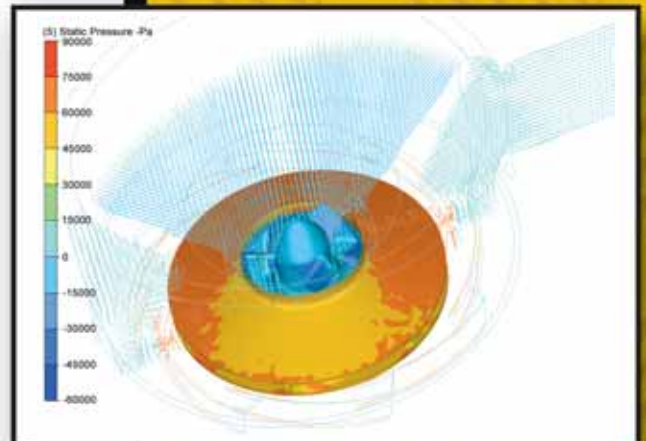

NEW, SUPER-QUIET POOL PUMP

NEW FEATURES :

- WATER-SILENCED MOTOR
- DRY RUN PROTECTION
- HUGE LEAF BASKET
- TWO PIECE IMPELLER
- HIGH EFFICIENCY
- RUSTPROOF PLASTIC
- ADVANCED SEAL PROTECTION SYSTEM
- HIGH PERFORMANCE



DEPENDABLE

NEW

Innovative Design - Silensor features a system for protecting the vital mechanical seal within the pump. This seal separates the water from the motor, vital for safety and longevity. Silensor's unique seal protection system reduces wear on the mechanical seal by excluding debris from the seal area. Service life is extended and maintenance reduced.

Dry Run Protection - Automatic resetting 'Dry Run' protection will stop the pump when it has no water moving or present inside the unit, often resulting from a full leaf basket or a blocked filter. Dry running is the major cause of premature pump failure.

PERFORMANCE

NEW

Many Sizes - Silensor is available in a range of performance sizes to provide the ideal power plant for any domestic swimming pool or spa. To ensure that your selection is the most suitable, consult your local Davey pool dealer.

Clever Impeller Design - Silensor features a clever impeller design that provides exceptional air and water handling ability - a real benefit when operating with automatic cleaners that can introduce air into the plumbing system. The design also aids priming of the pump, which can improve the options for positioning the pump in more versatile locations.

CONVENIENT

NEW

Large Leaf Basket - All Silensor SLL models feature the largest leaf basket of any domestic swimming pool pump available.

More volume inside the basket allows longer intervals between cleaning, without reducing filtration efficiency or pump wear and tear. The large volume basket also allows an easy passage of water, adding to the efficiency and reducing water generated noise at the same time.

SILENSOR™

NOISE LEVEL

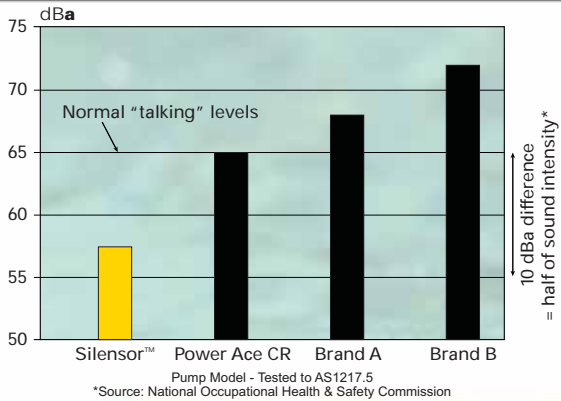

EFFICIENCY vs FLOW

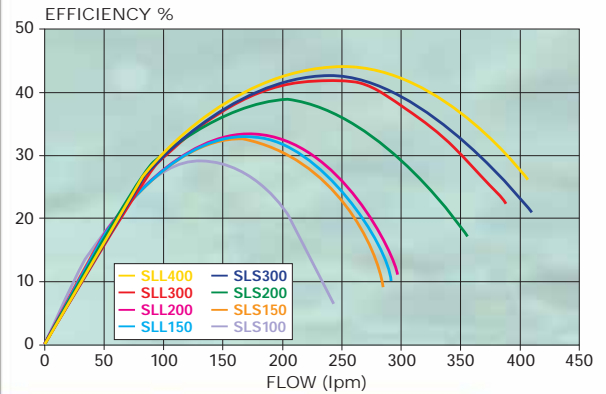

PERFORMANCE - SLS

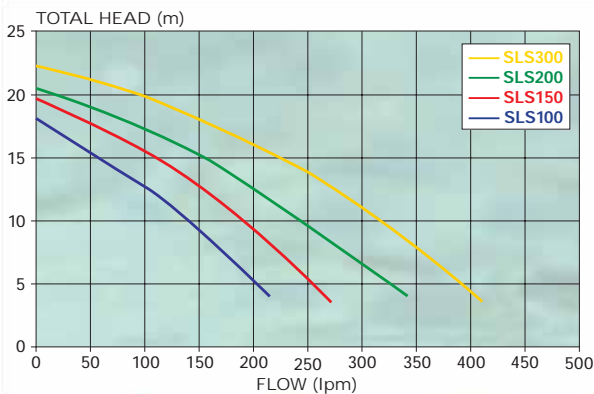

PERFORMANCE - SLL

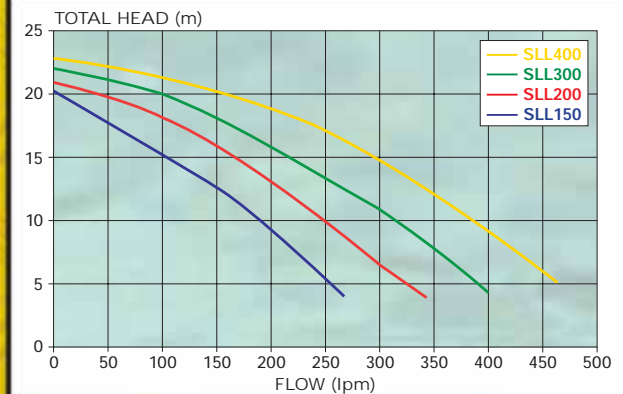

AVAILABLE FROM

Davey Products Pty Ltd

Member of the GUD Group
ABN 18 066 327 517
Head Office and Manufacturing
6 Lakeview Drive,
Scoresby, Australia 3179
Ph: +61 3 9730 9222
Fax: +61 3 9753 4100
Website: www.davey.com.au
Customer Service Centre
Ph: 1300 367 866
Fax: 1300 369 119
E-mail: sales@davey.com.au

Interstate Offices
Sydney • Brisbane • Adelaide
Perth • Townsville

International
6 Lakeview Drive, Scoresby, Australia 3179
Ph: +61 3 9730 9121
E-mail: export@davey.com.au
New Zealand
2 Rothwell Avenue, North Harbour, Auckland 1330
Ph: +64 9 914 3680
Website: www.daveynz.co.nz
E-mail: sales@daveynz.co.nz

Germany
Kantstrasse 47, 04275 Leipzig
Ph: +49 341 301 0412
E-mail: akrenz@daveyeurope.com

USA - Davey Pumps Inc.
1005 N. Commons Drive, Aurora, Illinois 60504
Ph: +1 630 898 6976
Website: www.daveyusa.com
E-mail: sales@daveyusa.com

DEPEND ON
DAVEY

WATER PRODUCTS



Visit Davey on-line for further information
www.davey.com.au

™ Silensor is a trademark of Davey Products Pty Ltd. © Davey is a registered trademark of Davey Products Pty Ltd.
© Davey Products Pty Ltd.
Note: All details in this leaflet are accurate at time of printing. This literature is not a complete guide to product usage. Further information is available from your Davey Customer Service Centre and from the relevant product Installation and Operating Instructions.



Silensor® SLS "SUPER-QUIET" POOL PUMPS

SILENSOR



Davey's all new water-silenced pool pumps offer super quiet operation with high efficiency, making them the ideal choice for modern swimming pools.

FEATURES & BENEFITS

Super-Quiet - Silensor's water-cooled motor uses a small water flow around the stainless steel, corrosion proof motor shell which captures noise and vibrations allowing the Silensor's super-quiet operation (typically below 56dBa).

Cost Saving - Silensor is designed using the latest computational fluid dynamics to move water up to 15% more efficiently than most standard pool pumps. Quietness may allow operation of the pumps late at night when energy costs are much lower (off peak).

Long Lasting - Silensor's advanced design utilises high performance UV stabilised polymers for outdoor installation. Bolts, screws and highly corrodible metals that can rust and render a pump unserviceable have also been replaced with easily operated clamp rings, ensuring simple maintenance, year after year.

Dependable - Silensor features a 'Floating Neckring' system for protecting the vital mechanical seal within the pump. This system will reduce wear by excluding debris, extending service life and reducing maintenance. Automatic 'Dry Run' protection will stop the pump running when it has no water moving inside the pump which is the major cause of premature pump failure.

Performance - Silensor features a patented clamped impeller design providing superior air and water handling ability. The design also aids priming of the pump, improving the options for positioning the pump in more versatile locations.

Convenient - SLS models are an ideal replacement for Davey PACR & PA models.

DEPEND ON
DAVEY

WATER PRODUCTS

DESIGNED & MADE IN AUSTRALIA 3yr FULL GUARANTEE

Silensor® SLS "SUPER-QUIET" POOL PUMPS

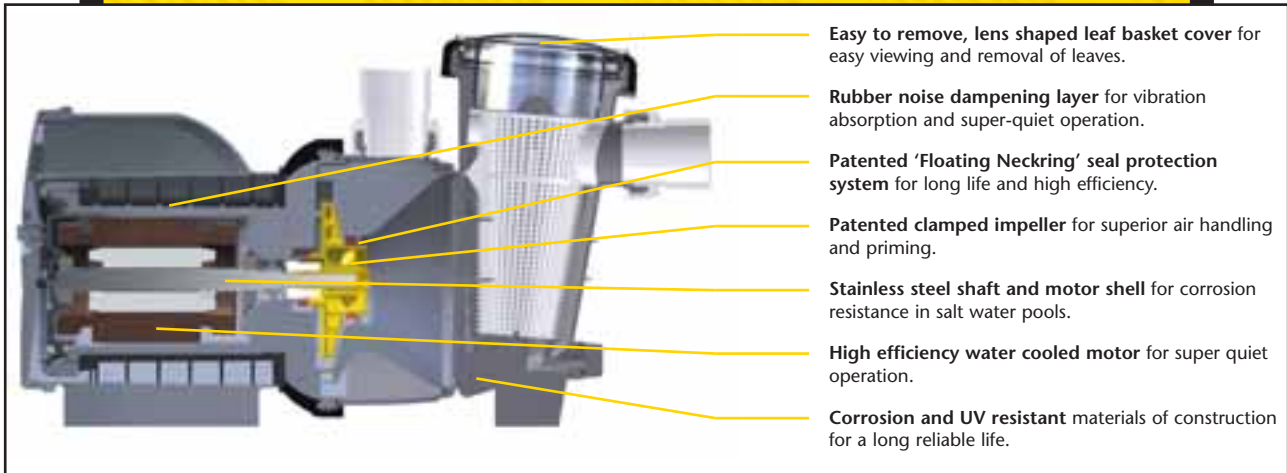

ELECTRICAL DATA

| Model No. | SLS 100 | SLS 150 | SLS 200 | SLS 300 |
|------------------------|---------|---------|---------|---------|
| Voltage (V) | 220-250 | | | |
| Supply Frequency | 50Hz | | | |
| Start Current (A) | 18 | 18 | 18 | 20 |
| Run Current (A) | 3.6 | 4.0 | 4.9 | 5.9 |
| Motor Input Power (W) | 740 | 860 | 1090 | 1400 |
| Motor Output Power (W) | 525 | 620 | 775 | 960 |
| RPM | 2850 | | | |
| Enclosure Class (IP) | 56 | | | |
| Insulation Class | F | | | |
| Approval No. | V06258 | | | |

OPERATING LIMITS

| Model No. | SLS 100 | SLS 150 | SLS 200 | SLS 300 |
|---------------------|----------|---------|---------|---------|
| Water Temperature | Max 50°C | | | |
| Ambient Temperature | Max 55°C | | | |
| dBa @ 1 metre | 56 | 55 | 54 | 54 |

MODEL NUMBER IDENTIFICATION

| SLS | 300 |
|--|---|
| SLS = Silensor Small (PACR Replacement) | 300 = 300lpm in a typical installation. |

| MODEL | Mounting Holes Dia. | Inlet P.V.C. (mm) | Outlet P.V.C. (mm) | Net Weight (kg) |
|---------|---------------------|-------------------|--------------------|-----------------|
| SLS 100 | 10mm x 34mm deep | 40/50 | 40/50 | 11.0 |
| SLS 150 | | 40/50 | 40/50 | 11.0 |
| SLS 200 | | 40/50 | 40/50 | 11.5 |
| SLS 300 | | 40/50 | 40/50 | 11.5 |

All dimensions in mm unless otherwise stated.

HYDRAULIC PERFORMANCE

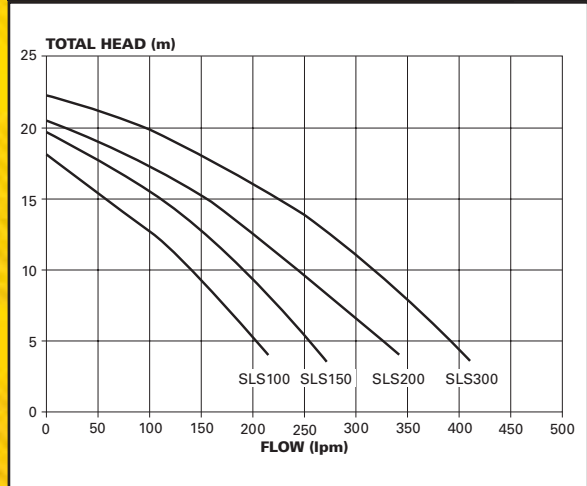

DIMENSIONS

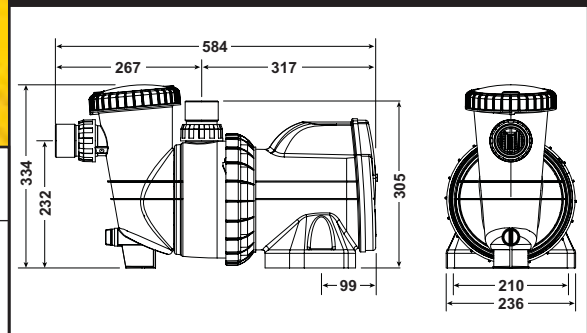

DEPEND ON
DAVEY

WATER PRODUCTS



Visit Davey on-line for further information
davey.com.au

All details in this leaflet are accurate at time of printing. This literature is not a complete guide to product usage. Further information is available from your Davey dealer, Davey Customer Service Centre and from the relevant product Installation & Operating Instructions. This datasheet must be read in conjunction with the relevant product Installation & Operating Instructions and all applicable statutory requirements. Product specifications may change without notice. © Davey and Silensor are registered trademarks of Davey Water Products Pty Ltd. © Davey Water Products Pty Ltd 2006.

Davey Water Products Pty Ltd

Member of the GUD Group
ABN 18 066 327 517
Head Office and Manufacturing
6 Lakeview Drive, Scoresby, Australia 3179
Ph: +61 3 9730 9222
Fax: +61 3 9753 4100
Website: davey.com.au
Customer Service Centre
Ph: 1300 2 DAVEY
Fax: 1300 304 850
E-mail: sales@davey.com.au
Interstate Offices
Sydney • Brisbane • Adelaide • Perth • Townsville

International

6 Lakeview Drive,
Scoresby, Australia 3179
Ph: +61 3 9730 9121
E-mail: export@davey.com.au

New Zealand

7 Rockridge Avenue,
Penrose, Auckland 1330
Ph: +64 9 570 9135
Website: daveynz.co.nz
E-mail: sales@daveynz.co.nz

Germany

Kantstrasse 53,
04275 Leipzig
Ph: +49 341 301 0412
E-mail: akrenz@daveyeurope.com

USA - Davey Pumps Inc.

1005 N. Commons Drive,
Aurora, Illinois 60504
Ph: +1 630 898 6976
Website: daveyusa.com
E-mail: sales@daveyusa.com

Silensor® SLL "SUPER-QUIET" POOL PUMPS

SILENSOR



Davey's all new water-silenced pool pumps offer super quiet operation with high efficiency, making them the ideal choice for modern swimming pools.

FEATURES & BENEFITS

Super-Quiet - Silensor's water-cooled motor uses a small water flow around the stainless steel, corrosion proof motor shell which captures noise and vibrations allowing the Silensor's super-quiet operation (typically below 56dBa).

Cost Saving - Silensor is designed using the latest computational fluid dynamics to move water up to 15% more efficiently than most standard pool pumps. Quietness may allow operation of the pumps late at night when energy costs are much lower (off peak).

Long Lasting - Silensor's advanced design utilises high performance UV stabilised polymers for outdoor installation. Bolts, screws and highly corrodible metals that can rust and render a pump unserviceable have also been replaced with easily operated clamp rings, ensuring simple maintenance, year after year.

Dependable - Silensor features a 'Floating Neckring' system for protecting the vital mechanical seal within the pump. This system will reduce wear by excluding debris, extending service life and reducing maintenance. Automatic 'Dry Run' protection will stop the pump running when it has no water moving inside the pump which is the major cause of premature pump failure.

Performance - Silensor features a patented clamped impeller design providing superior air and water handling ability. The design also aids priming of the pump, improving the options for positioning the pump in more versatile locations.

Convenient - SLL models feature a huge 4.5 litre leaf basket for long intervals between cleaning.

DEPEND ON
DAVEY

WATER PRODUCTS

DESIGNED & MADE IN AUSTRALIA 3yr FULL GUARANTEE

Silensor® SLL "SUPER-QUIET" POOL PUMPS

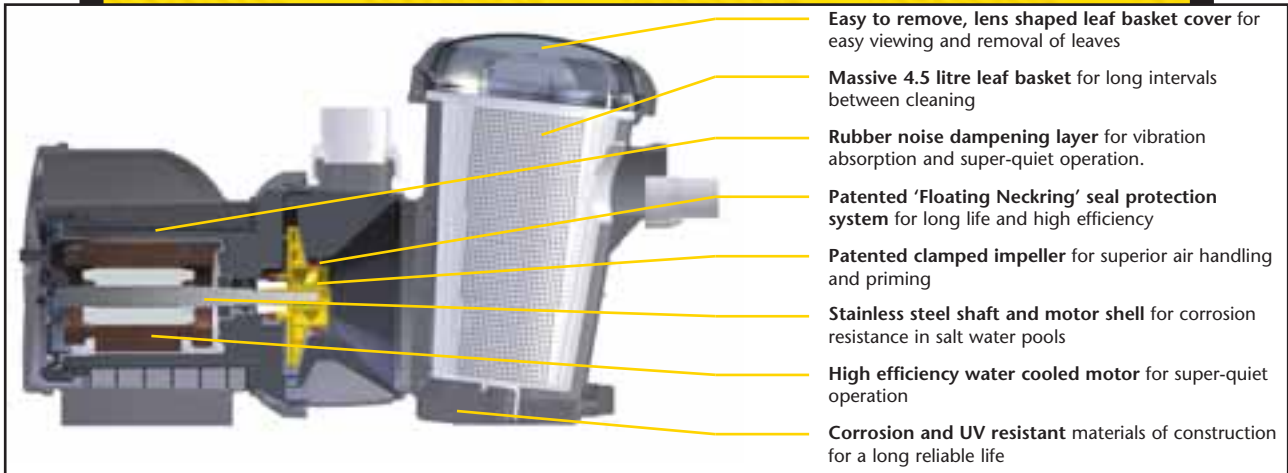

ELECTRICAL DATA

| Model No. | SLL 150 | SLL 200 | SLL 300 | SLL 400 |
|------------------------|---------|---------|---------|---------|
| Voltage (V) | 220-250 | | | |
| Supply Frequency | 50Hz | | | |
| Start Current (A) | 18 | 20 | 20 | 24 |
| Run Current (A) | 4.0 | 4.8 | 5.9 | 7.4 |
| Motor Input Power (W) | 870 | 1130 | 1400 | 1760 |
| Motor Output Power (W) | 635 | 830 | 960 | 1200 |
| RPM | 2850 | | | |
| Enclosure Class (IP) | 56 | | | |
| Insulation Class | F | | | |
| Approval No. | V06258 | | | |

OPERATING LIMITS

| | |
|---------------------|----------|
| Water Temperature | Max 50°C |
| Ambient Temperature | Max 55°C |
| dBa @ 1 metre | 55 |

HYDRAULIC PERFORMANCE

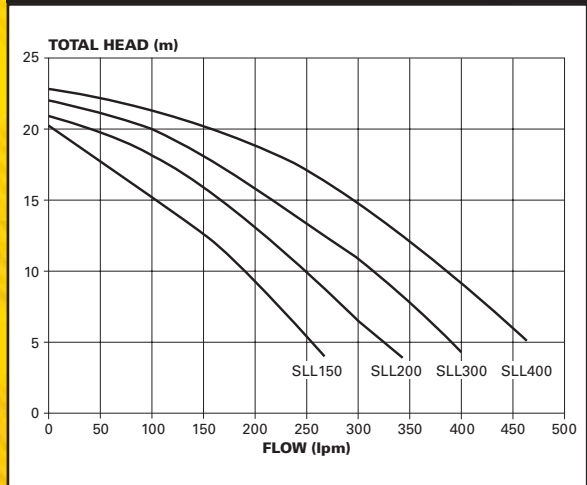

MODEL NUMBER IDENTIFICATION

| SLL | 400 |
|----------------------|---|
| SLL = Silensor Large | 400 = 400lpm in a typical installation. |

DIMENSIONS

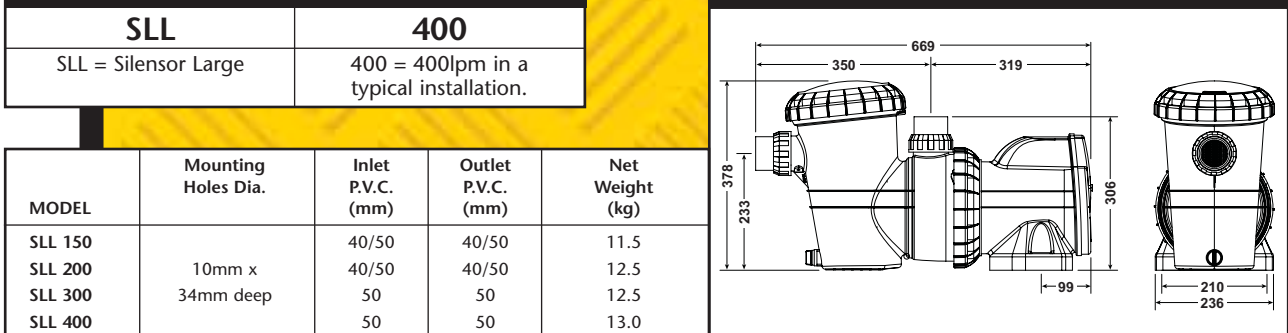

All dimensions in mm unless otherwise stated.

DEPEND ON
DAVEY

WATER PRODUCTS



Visit Davey on-line for further information
davey.com.au

All details in this leaflet are accurate at time of printing. This literature is not a complete guide to product usage. Further information is available from your Davey dealer, Davey Customer Service Centre and from the relevant product Installation & Operating Instructions. This datasheet must be read in conjunction with the relevant product Installation & Operating Instructions and all applicable statutory requirements. Product specifications may change without notice. © Davey and Silensor are registered trademarks of Davey Water Products Pty Ltd. © Davey Water Products Pty Ltd 2006.

Davey Water Products Pty Ltd

Member of the GUD Group
ABN 18 066 327 517
Head Office and Manufacturing
6 Lakeview Drive, Scoresby, Australia 3179
Ph: +61 3 9730 9222
Fax: +61 3 9753 4100
Website: davey.com.au
Customer Service Centre
Ph: 1300 2 DAVEY
Fax: 1300 304 850
E-mail: sales@davey.com.au
Interstate Offices
Sydney • Brisbane • Adelaide • Perth • Townsville

International

6 Lakeview Drive,
Scoresby, Australia 3179
Ph: +61 3 9730 9121
E-mail: export@davey.com.au

New Zealand

7 Rockridge Avenue,
Penrose, Auckland 1330
Ph: +64 9 570 9135
Website: daveynz.co.nz
E-mail: sales@daveynz.co.nz

Germany

Kantstrasse 53,
04275 Leipzig
Ph: +49 341 301 0412
E-mail: akrenz@daveyeurope.com

USA - Davey Pumps Inc.

1005 N. Commons Drive,
Aurora, Illinois 60504
Ph: +1 630 898 6976
Website: daveyusa.com
E-mail: sales@daveyusa.com