



GARBARINO

PUMPS SINCE 1932

BT

Side channel centrifugal pumps
Pompe centrifughe a canali laterali

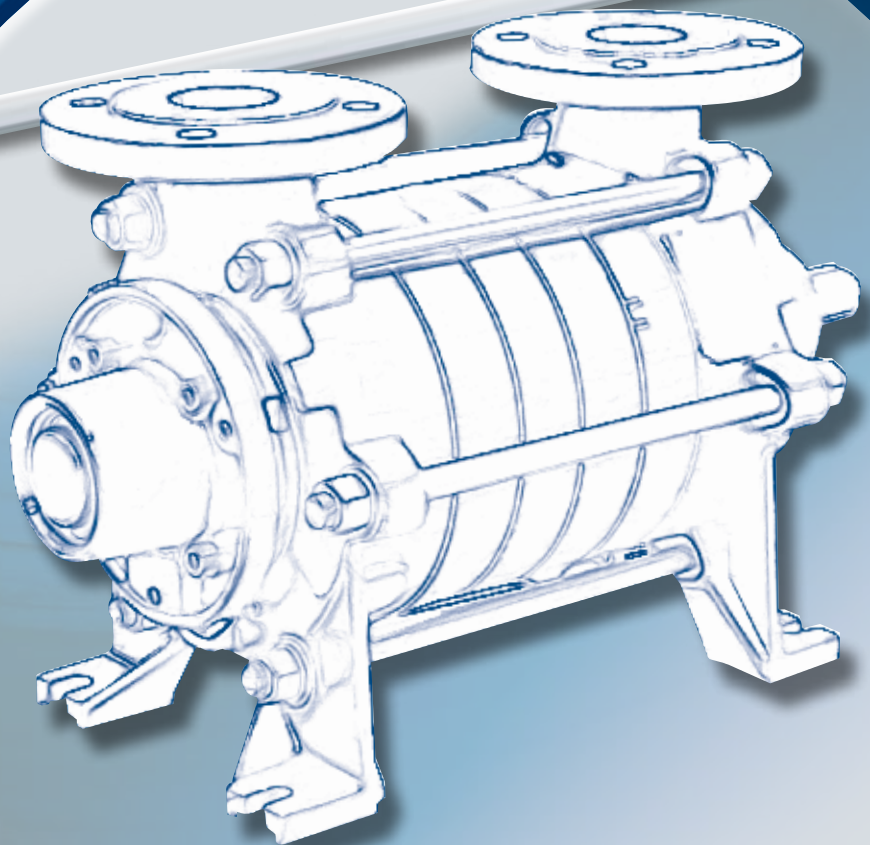



BT

SIDE CHANNEL CENTRIFUGAL PUMPS

*POMPE CENTRIFUGHE
A CANALI LATERALI*

APPLICATIONS

- For drinking water and industrial purposes
- For sea water
- For automatic system with hydrofore tank
- For conveying acid and alkaline liquids, petrol and light oils
- For condensate and liquid with vapours
- For food and pharmaceutical products

IMPIEGHI

- *Per acqua potabile ed industriale in genere*
- *Per acqua di mare*
- *Per impianti automatici con serbatoio autoclave*
- *Per convogliamento di liquidi acidi ed alcalini, benzine ed olii leggeri*
- *Per condensato e liquidi contenenti vapori*

DESIGN FEATURES

BT pumps are self-priming side channel multistage pumps. The impellers are multi bladed, hydraulically balanced to reduce axial thrust on the bearings. Bearings are external, life grease lubricated. The pumps have a very low NPSHr value that allows operation with suction lift up to 8 meters. Their working principle makes these pumps particularly suitable to transfer liquid-gas/vapour mixtures.

Basic design pumps are mechanically sealed. It is possible to fit double mechanical seals when handling hot liquids which may solidify, toxic, aggressive and corrosive media. In this case the seals are flushed from an external source with a fluid compatible with pumped medium at a slightly higher pressure.

CARATTERISTICHE COSTRUTTIVE

Le pompe della serie BT sono autoadescanti multicellulari a canali laterali. Le giranti sono "stellari" autobilanciate idraulicamente in modo da eliminare le spinte assiali sui cuscinetti. La supportazione è realizzata con due cuscinetti esterni al corpo pompa stagni e lubrificati a grasso. Le pompe sono caratterizzate da un NPSH molto basso che permette di lavorare con altezze di aspirazione fino a 8 metri. Il principio di funzionamento a canali laterali rende queste pompe particolarmente adatte a pompare liquidi contenenti vapori o gas. Esecuzione standard con tenute meccaniche singole normalizzate. Possibilità di installare tenute meccaniche doppie quando si devono pompare liquidi caldi tendenti a solidificarsi, liquidi tossici, liquidi aggressivi; in questo caso le tenute sono flussate dall'esterno con liquido compatibile al pompato con pressione superiore a quella del liquido da tenere.

OPERATING PRESSURES AND TEMPERATURES

Up to 120°C : 40 bar

Over to 120°C : 16 bar

Max operating temperature: with mechanical seal: 160°C

Minimum operation temperature: -10°C

PRESSIONI E TEMPERATURE DI ESERCIZIO

Fino a 120 °C : 40 bar

Oltre i 120 °C : 16 bar

Temperature massima: con tenuta meccanica: 160 °C

Temperatura minima: -10 °C

MATERIALS

Construction is provided in the following materials: cast-iron, different types of bronze and stainless steel. Special constructions according to Naval Rules: shock-proof, noise-proof, vibration-proof, non magnetic versions.

MATERIALI

Sono previste costruzioni in ghisa, vari tipi di bronzo e acciai inossidabili. Costruzioni speciali a norma Marina Militare (antishock, antirumore, antivibrazioni, versioni amagnetiche).



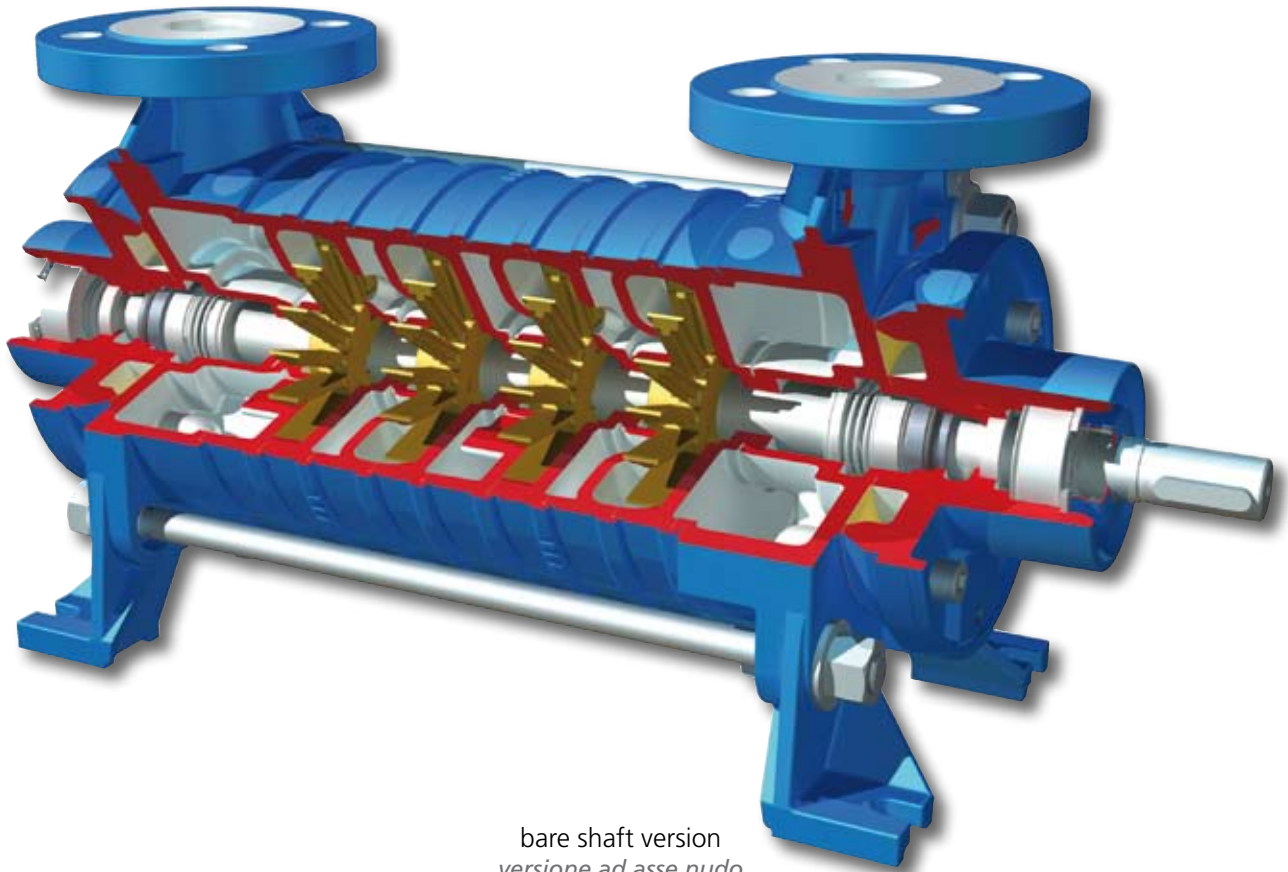

bare shaft version
versione ad asse nudo



multi blade impeller
girante stellare



vertical version
versione verticale



coupling and baseplate version
versione con giunto e basamento

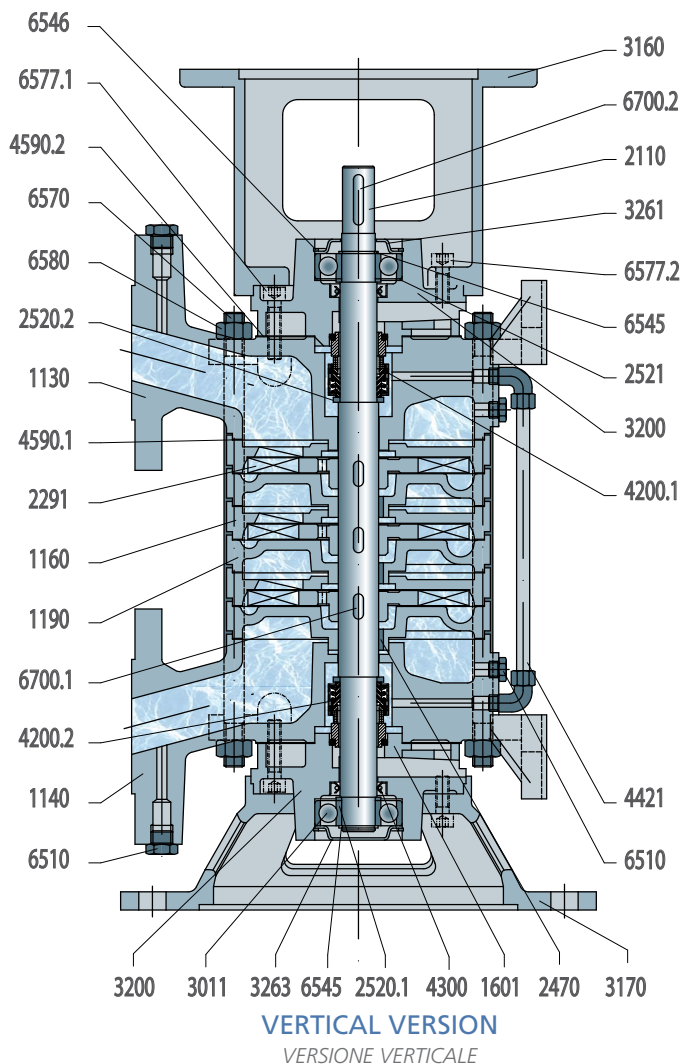
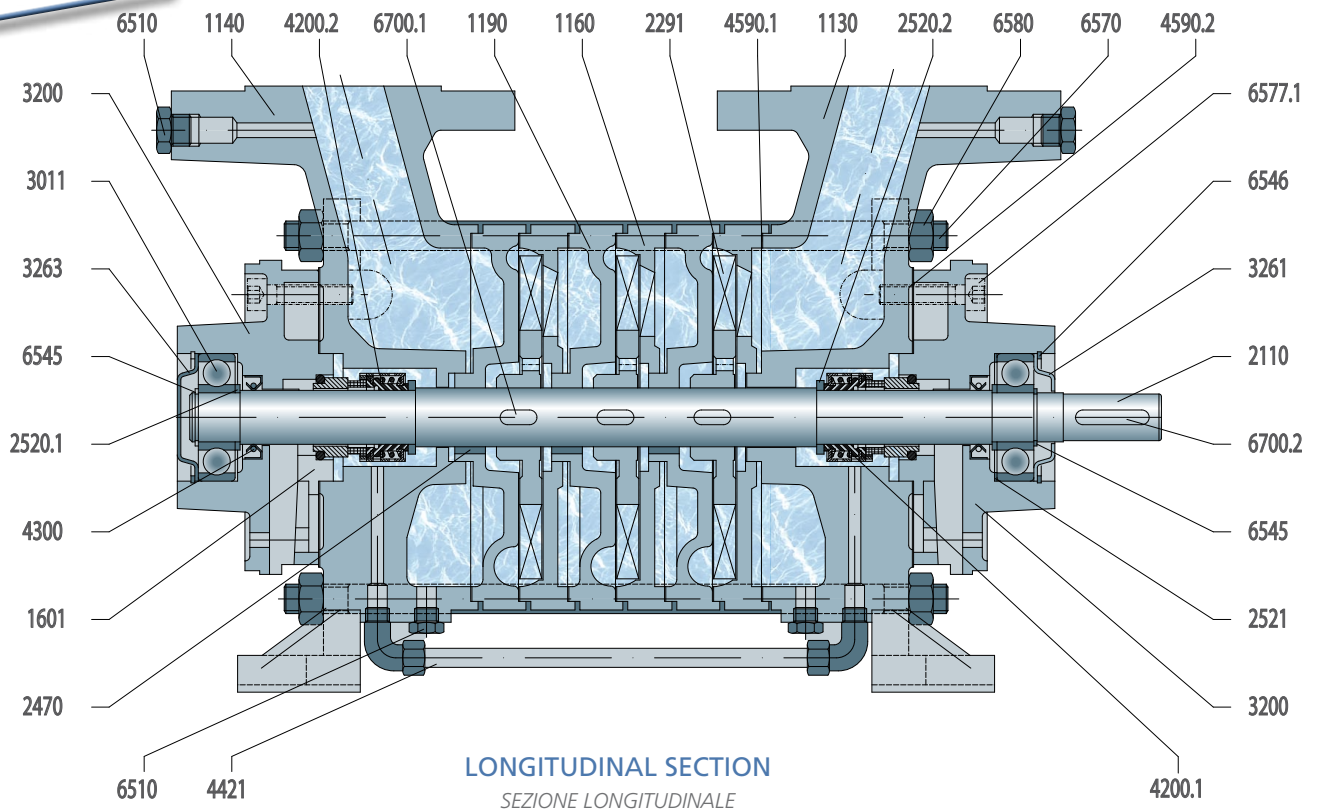

Pos	Description	Descrizione
1130	Suction casing	Corpo aspirante
1140	Discharge casing	Corpo premente
1160	Stage casing	Corpo a mantello
1190	Side channel casing	Corpo a canali laterali
1601	Seal bush	Boccola per tenuta
2110	Pump shaft	Albero della pompa
2291	Side channel impeller	Girante stellare
2470	Centering sleeve	Bussola di centraggio
2520.1	Shoulder ring	Anello di spallamento
2520.2	Shoulder ring	Anello di spallamento
2521	Flexible spacer ring	Anello elastico
3011	Radial ball bearing	Cuscinetto a sfere
3160	Motor stool	Lanterna del motore
3170	Pump stool	Basamento pompa
3200	Bearing housing	Supporto
3261	Bearing cover	Coperchio del supporto
3263	Bearing cover	Coperchio del supporto
4200.1	Mechanical seal	Tenuta meccanica
4200.2	Mechanical seal	Tenuta meccanica
4300	Radial shaft seal	Anello di tenuta
4421	Shaft seal pipe	Condotto lubrificazione
4590.1	Gasket	Guarnizione
4590.2	Gasket	Guarnizione
6510	Plug	Tappo
6545	Seeger	Seeger
6546	Seeger	Seeger
6570	Tie bolt	Tirante filettato
6577.1	Screw	Vite
6577.2	Screw	Vite
6580	Nut	Dado
6700.1	Key	Chiavetta
6700.2	Key	Chiavetta

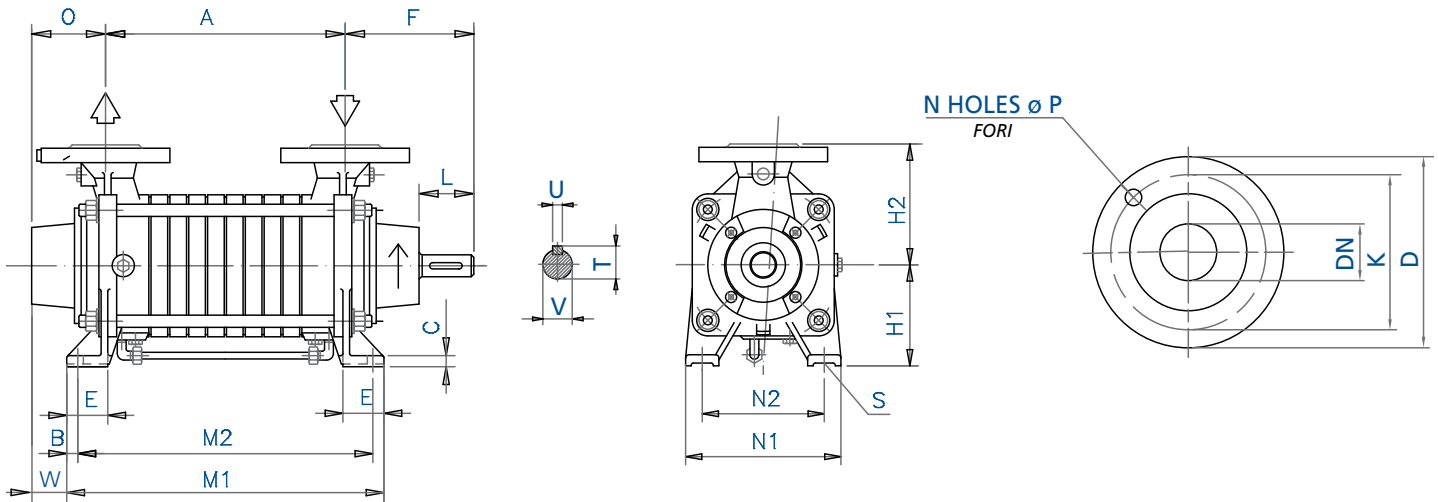

OVERALL DIMENSIONS (mm)

DIMENSIONI D'INGOMBRO

PUMP TYPE TIPO POMPA	A	B	C	E	F	H1	H2	M1	M2	N1	N2	O	S	V	T	U	L	DN	D	K	N	P	W	WEIGHT PESO KG
BT 201	108	12	11	40	108,5	100	100	182	158	140	105	71	12	14	16	5	35	20	105	75	4	14	34	14,5
BT 202	142	12	11	40	108,5	100	100	216	192	140	105	71	12	14	16	5	35	20	105	75	4	14	34	16
BT 203	176	12	11	40	108,5	100	100	250	226	140	105	71	12	14	16	5	35	20	105	75	4	14	34	17,5
BT 204	210	12	11	40	108,5	100	100	284	260	140	105	71	12	14	16	5	35	20	105	75	4	14	34	19
BT 205	244	12	11	40	108,5	100	100	318	294	140	105	71	12	14	16	5	35	20	105	75	4	14	34	20,5
BT 206	278	12	11	40	108,5	100	100	352	328	140	105	71	12	14	16	5	35	20	105	75	4	14	34	22
BT 291-301-311	144	12	12	45	113	112	135	228	204	170	135	70	12	19	21,5	6	40	32	140	100	4	18	28	22,5
BT 292-302-312	184	12	12	45	113	112	135	268	244	170	135	70	12	19	21,5	6	40	32	140	100	4	18	28	26
BT 293-303-313	224	12	12	45	113	112	135	308	284	170	135	70	12	19	21,5	6	40	32	140	100	4	18	28	29,5
BT 294-304-314	264	12	12	45	113	112	135	348	324	170	135	70	12	19	21,5	6	40	32	140	100	4	18	28	33
BT 295-305-315	304	12	12	45	113	112	135	388	364	170	135	70	12	19	21,5	6	40	32	140	100	4	18	28	36,5
BT 296-306-316	344	12	12	45	113	112	135	428	404	170	135	70	12	19	21,5	6	40	32	140	100	4	18	28	40
BT 297-307-317	384	12	12	45	113	112	135	468	444	170	135	70	12	19	21,5	6	40	32	140	100	4	18	28	43,5
BT 401	152	12	13	50	151	132	140	252	228	195	155	97	12	24	27	8	45	40	150	110	4	18	47	30
BT 402	207	12	13	50	151	132	140	307	283	195	155	97	12	24	27	8	45	40	150	110	4	18	47	35
BT 403	262	12	13	50	151	132	140	362	338	195	155	97	12	24	27	8	45	40	150	110	4	18	47	40
BT 404	317	12	13	50	151	132	140	417	393	195	155	97	12	24	27	8	45	40	150	110	4	18	47	45
BT 405	372	12	13	50	151	132	140	472	448	195	155	97	12	24	27	8	45	40	150	110	4	18	47	50
BT 406	427	12	13	50	151	132	140	527	503	195	155	97	12	24	27	8	45	40	150	110	4	18	47	55
BT 501	171	15	15	55	151	160	165	281	251	215	170	97	14	24	27	8	45	50	165	125	4	18	42	39
BT 502	246	15	15	55	151	160	165	356	326	215	170	97	14	24	27	8	45	50	165	125	4	18	42	49
BT 503	321	15	15	55	151	160	165	431	401	215	170	97	14	24	27	8	45	50	165	125	4	18	42	59
BT 504	396	15	15	55	151	160	165	506	476	215	170	97	14	24	27	8	45	50	165	125	4	18	42	69
BT 505	471	15	15	55	151	160	165	581	551	215	170	97	14	24	27	8	45	50	165	125	4	18	42	79
BT 506	546	15	15	55	151	160	165	656	626	215	170	97	14	24	27	8	45	50	165	125	4	18	42	89
BT 651	190	15	16	55	184	180	180	300	270	245	195	117	14	28	31	8	65	65	185	145	4	18	62	52
BT 652	280	15	16	55	184	180	180	390	360	245	195	117	14	28	31	8	65	65	185	145	4	18	62	67
BT 653	370	15	16	55	184	180	180	480	450	245	195	117	14	28	31	8	65	65	185	145	4	18	62	82
BT 654	460	15	16	55	184	180	180	570	540	245	195	117	14	28	31	8	65	65	185	145	4	18	62	97
BT 655	550	15	16	55	184	180	180	660	630	245	195	117	14	28	31	8	65	65	185	145	4	18	62	112



PERFORMANCE TABLE

Data refer to liquids with following properties:
 Viscosity 1 centistoke.
 Specific gravity: 1 Kg/dm³

CAST IRON - BRONZE: Q/ H= ± 5%
 P= 0/+10%

STAINLESS STEEL: Q= ± 5%
 H= 0/-10%
 P= 0/+10%

DATI DI FUNZIONAMENTO

Caratteristiche per liquidi aventi:
 Viscosità=1°cSt.
 Peso specifico: 1 Kg/dm³

GHISA - BRONZO: Q/ H= ± 5%
 P= 0/+10%

ACCIAIO INOSSIDABILE: Q= ± 5%
 H= 0/-10%
 P= 0/+10%

OPERATING CHARTS CAMPI DI LAVORO

1450 RPM - 50 Hz

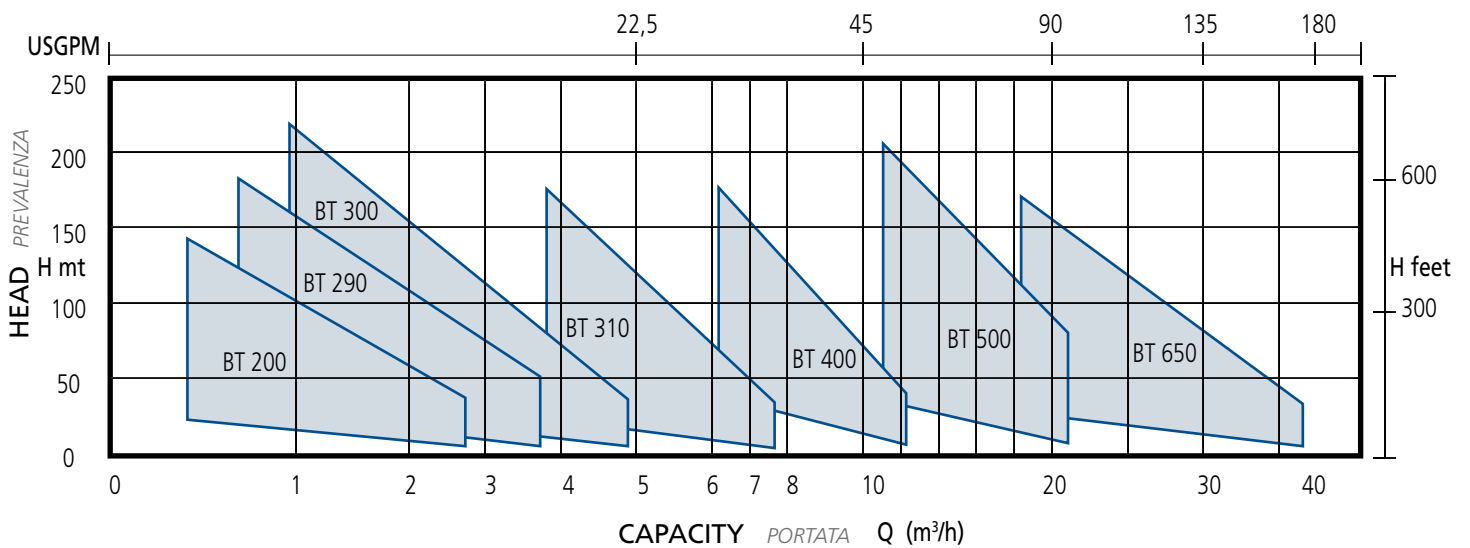

1750 RPM - 60 Hz

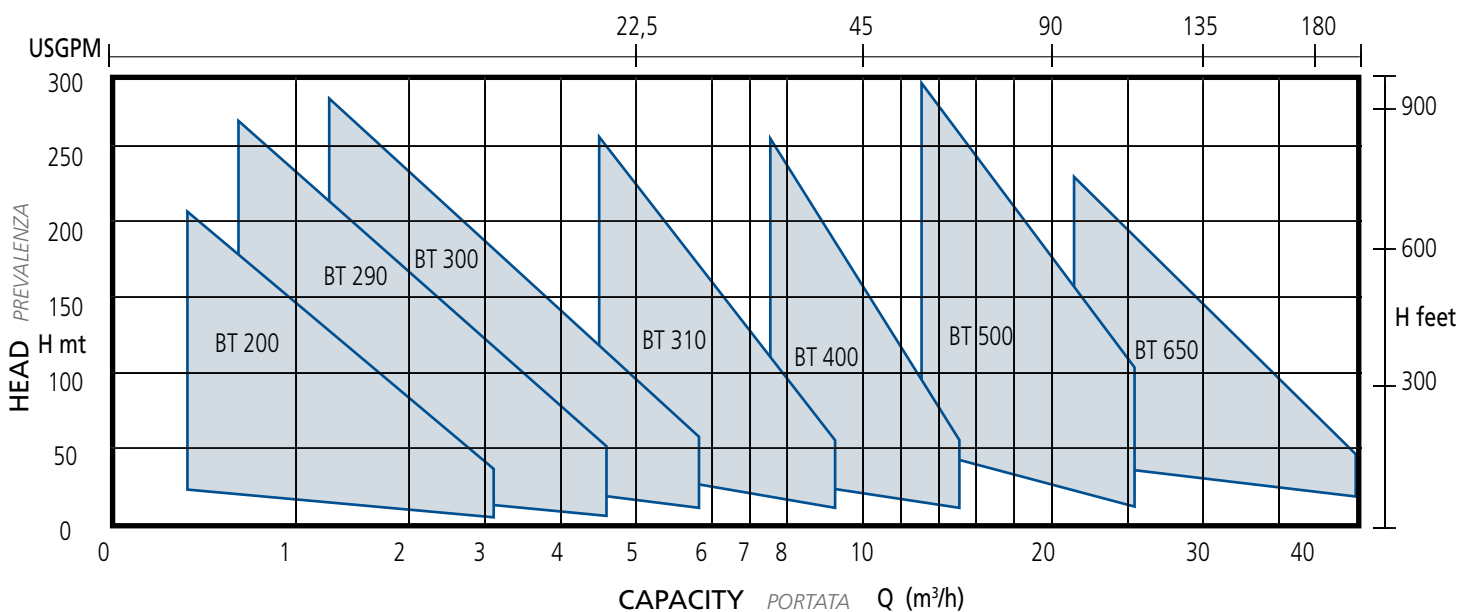

CAPACITY PORTATA		Q	m ³ /h	0,3	0,6	0,9	1,5	2,4	3,6	4,8	6	7,5				
			l/min	5	10	15	25	40	60	80	100	125				
TYPE				H	KW	H	KW	H	KW	H	KW	H	KW	H	KW	
TIPO																
BT 201	BRANCHES Ø 20 BOCCHE Ø 20			25	0,48	23	0,45	20	0,4	15	0,35	8	0,25			
BT 202				50	0,9	46	0,8	40	0,75	30	0,6	15	0,45			
BT 203				74	1,3	70	1,2	60	1,1	45	0,9	21	0,6			
BT 204				98	1,65	92	1,55	80	1,4	60	1,2	28	0,8			
BT 205				123	2,1	114	1,9	100	1,75	75	1,1	35	0,9			
BT 206				148	2,5	139	2,3	120	2,05	90	1,7	40	1,1			
NPSH m				2		2		2		2,2		3,1				
BT 291	BRANCHES Ø 32 BOCCHE Ø 32					34	0,65	31,5	0,6	28	0,55	20	0,45	10	0,35	
BT 292						68	1,25	63	1,2	56	1,15	40	1	20	0,8	
BT 293						102	2	94,5	1,9	82	1,75	60	1,45	30	1,2	
BT 294						136	2,65	126	2,6	109	2,35	80	2	40	1,55	
BT 295						170	3,4	157	3,25	137	2,95	98	2,5	50	1,9	
BT 296						204	4,1	190	4	163	3,5	119	3,1	60	2,35	
NPSH m						1		1		1,1		1,2		1,5		
BT 301	BRANCHES Ø 32 BOCCHE Ø 32							40	1	35	0,9	25	0,75	16	0,55	
BT 302								80	2	70	1,85	55	1,5	35	1,1	
BT 303									120	2,95	105	2,5	80	2,2	50	1,6
BT 304									159	4,05	140	3,7	108	3	70	2,8
BT 305									198	5	170	4,55	130	3,85	85	3,3
BT 306									235	5,9	205	5,3	160	4,4	101	3,35
NPSH m								1,1		1,1		1,2		1,5	2,2	
BT 311	BRANCHES Ø 32 BOCCHE Ø 32									25	0,95	20	0,75	12	0,55	
BT 312										50	1,85	40	1,55	25	1,2	
BT 313										78	2,85	60	2,35	40	1,75	
BT 314										104	3,85	80	3,15	50	2,35	
BT 315										129	4,8	98	4,05	69	2,95	
BT 316										153	5,65	117	4,8	80	3,45	
BT 317										180	6,6	135	5,5	92	4,05	
NPSH m										1,6		1,7		2,2	3	
CAPACITY PORTATA		Q	m ³ /h	6	7,5	9	10,5	12	15	18	21	24	30	36		
			l/min	100	125	150	175	200	250	300	250	400	500	600		
BT 401	BRANCHES Ø 40 BOCCHE Ø 40			32	1,7	28	1,5	20	1,35	12	1,1	7	0,9			
BT 402				63	3,25	50	2,85	40	2,3	27	2	14	1,5			
BT 403				95	4,95	78	4,25	60	3,55	40	2,85	21	2,15			
BT 404				125	6,55	100	5,75	78	4,7	52	3,7	29	2,95			
BT 405				155	8,1	125	7	95	5,9	66	4,8	35	3,6			
BT 406				185	9,55	150	8,1	115	6,9	80	5,5	42	4,25			
NPSH m				2		2,1		2,5		3		3,7				
BT 501	BRANCHES Ø 50 BOCCHE Ø 50							35	3,85	32	3,7	26	2,95	20	2,6	
BT 502								75	7,95	68	7,35	53	6,25	40	5,15	
BT 503								110	11,5	100	10,7	80	9,2	59	7,5	
BT 504								150	15,1	135	14	105	12,1	80	9,9	
BT 505								185	19	169	17,6	132	15,1	100	12,5	
BT 506								220	22,1	200	20,6	159	17,6	119	14,7	
NPSH m								2,4		2,5		2,7		3	3,5	
BT 651	BRANCHES Ø 65 BOCCHE Ø 65									37	6,4	31	5,6	27	5,5	
BT 652										74	12,5	65	11	53	9,9	
BT 653											110	18	95	16,2	80	14,7
BT 654											145	23,5	127	21	106	19,1
BT 655											185	28,7	160	26,5	132	23,5
NPSH m										4		4		4,2	4,5	
NPSH m															5	



ATEX on request



POMPE GARBARINO S.p.A.

Headquarters:

Via Marengo, 44 - 15011 Acqui Terme (AL) - Italy - Tel. +39 0144.388671 - Fax +39 0144.55260
E-mail: info@pompegarbarino.it

Milan Branch:

Viale Andrea Doria, 31 - 20124 Milano - Italy - Tel. +39 02.67070037 - Fax +39 02.67070097
E-mail: info.filiale@pompegarbarino.it

www.pompegarbarino.com