

Graymills

PUMP PRODUCTS CATALOG



Pumps

Pump and Tank Systems

Filters

Accessories

graymills.com 1.888.GRAYMILLS (1-888-472-9645)

Pump/Reference Flow Chart

Graymills offers pumps and systems for a wide variety of industrial applications, including:

- Centrifugal Pumps in Immersion, Suction and Flange-Mount Sidewall Styles
- Machine Tool Coolant Pumps in conventional and high-pressure models; and for use as replacements in existing equipment
- Gear Pumps for heavy liquids and greases
- Drum and Transfer Pumps
- Corrosion Resistant Pumps
- Standard Pump/Tank Systems from 2 to 110 gallons capacity available upon request.
- Filtration and Oil Coalescing Products
- Coil/Strip Stock Lubrication Systems

If you don't see a standard product or system to fit your specific application, contact the factory or a Graymills representative at **1-888-472-9645** or at info@graymills.com.

PUMP	Approximate GPM of Water at Specific Feet of Head																		
	5'	10'	14'	18'	24'	35'	45'	55'	60'	65'	70'	80'	85'	90'	100'	110'	120'	130'	140'
HR15H	6																		
HR35	12																		
HR45	14	4																	
FM60H		18	15	8															
FM70H			18	14	5														
TN30		30	17																
TN40		48	37	22															
TN50			72	54	20														
TN60			120	100	40														
TN70			160	140	70														
TN30H1/4		30	25	8															
TN30H1/2					36	28													
TN30H3/4						45	25												
TN30H1							35	25											
TN30H1-1/2								50	42	30	10								
TN40H								62	55	40	18								
TN50H									90	79	68	43	20						
TN50HH									100	90	80	60	40						
LV20	25	18	10																
LV40			30	26	20														
LV50			36	34	30	20													
LV60				42	37	30	18												
LV70					45	35	30	10											
VP30	10	6																	
VP40	12	9	6																
VP50	13	10	7	2															
HP500A												150	50						
HP500B														100					
HP500C															100				
HP750B																210	100		
HP750C																	125		
HP750D																			50
HP1000C																			
HP1000D																			
HSP115		110	105	100	95	80	60	40											
HSP120								75											
HSP130								105											
HSP150						160	155	150	140	135	132	130	120	115	110	95	80	45	
HSP230							135	115	90	70	40								
HSP250							190	174	165	155	145	125	113	100					

PUMP	Approximate GPM of Water at Specific Feet of Head																		
	5'	10'	15'	20'	25'	35'	45'	50'	55'	60'	65'	70'	75'	80'	100'	125'	150'	175'	200'
BSW/CSW 300H1/6	16	12	5																
BSW/CSW 300H1/4		18	11	3															
BSW/CSW 300H1/2				45	38	10													
BSW/CSW 300H3/4				47	47	28													
DSW/ESW 300H1/4		22	11																
DSW/ESW 400H1/2			40	25															
DSW/ESW 300H1/2					37														
DSW/ESW 300H3/4						30													
DSW/ESW 300H1						48	28												
DSW/ESW 300H1-1/2							48	39	28	16									
DSW/ESW 400H2							80	68	50	33	15								
DSW/ESW 500H3								90	80	68	55	42	22						
IMS08	4																		
IMV08	4																		
IMS25	18	14	11	9	6														
IMV25	18	14	11	9	6														
IMS50	37	33	30	27	22	12													
IMV50	37	33	30	27	22	12													
IMS75	47	45	42	40	37	29	19												
IMV75	47	45	42	40	37	29	19												
IMS100	50	48	47	44	41	35	26	21	15										
IMV100	50	48	47	44	41	35	26	21	15										
Double Diaphragm 1/4"								1.4	1.3	1.2	1.2	1.1	1.1	0.9	0.8	0.5			
Double Diaphragm 1/2"								7.5	7.4	7.1	6.9	6.9	6.0	5.0	4.1	2.1			
Double Diaphragm 3/4"								11	11	10.7	10.7	10.3	10	9.5	9	8	6	4	2
Double Diaphragm 1"								21	21	20	19	18	17	15	12	6			

PUMP	Approximate GPM of Water at Specific Feet of Head																		
	25'	35'	45'	50'	75'	100'	125'	150'	175'	200'	250'	300'	350'	400'	450'	500'	550'	600'	700'
MSPR5					35	31	27	18	10										
MSPR7					36	34	32	29	25	18	10								
MSPR9					37	36	34	32	30	27	24	10							
MSPR13					37	36	36	34	33	32	30	27	22	16	10				
MVP4	28	26	26	25	20	10	8	0											
MVP6		27	26	25	24	22	20	17	13	7									
MVP8		27	26	25	25	25	23	22	19	17	5								
MVP12		27	26	26	26	26	26	26	26	24	22	17	13	6					
MVP16		27	27	27	27	27	27	27	27	26	25	22	17	13	6	14	10	5	
MVP20		27	27	27	27	27	27	27	27	26	25	23	21	19	17	14	11	2	



Agitator Series



TN Series



IM Series



VP Series



HP Series



MVP Pump

A. Pump Selection 4

B. Pumps by Type

Centrifugal	
Immersion	6-16
Suction	17
Flange ("Side Wall") Mount	18-19
Multi-Stage	20-21
Double Diaphragm Pumps	22-23
Gear Pumps (SG)	24

Pumps—Application Specific

Keeping Solids in Suspension (Agitator)	
TNRT/TNRSS	9
HRTG	9
Water & Corrosion Resistant	
TNRT/TNRSS	9
HRTG	9
HSP	13
VP	14
LV	15
MSPRSS	21
Machine Tool Coolants	
TN	6-8
HR	10
FM	11
HP, HSP	12-13
IMV/IMS	16-17
BSW, CSW, DSW, ESW	18-19
MVP	20
MSPR/MSPRSS	21
High Pressure, Multi-Stage	
MVP	20
MSPR/MSPRSS	21
Heavy Liquids	
Double Diaphragm	22-23
SG	24
Drum Pumps	
TNRT	9
Double Diaphragm	22-23

C. Pump and Tank Systems

3-50 Gallon Tank Capacity	25-28
85 and 110 Gallon Tank Capacity	29
Agitator Round Tank	25
Low Profile Tank Systems	29
Custom/OEM Tank Systems	26

D. Filtration/Oil Coalescing

Oil Separators/Coalescer	32
Bed Filter/Magnetic Separator	33
Filters/Surge Suppressor Filters	35

E. Lubrication Systems for Coil/Strip Stock

Stock Lubricating Systems	30-31
---------------------------------	-------

F. Accessories

Pump Mounting Adapters	34
Pail Liners, Hoses, Other	35
Drum Length Mixer	35



A-B.



C.



D.



E.



F.

Pump Selection

HOW TO USE THIS SECTION

The following information identifies the major factors to be considered in specifying a pump. If you are familiar with pump applications, you will need to refer only to the Motor Selection information in this section. Flow charts for each model appear throughout the pump section.

TO SELECT THE RIGHT PUMP

The more data you can identify, the more quickly and precisely an appropriate pump can be specified.

1. Maximum flow required (GPM).
2. Maximum pressure required (See TDH).
3. Description of the proposed piping installation. (Pipe diameter, height to which liquid will be pumped, number of fittings, total piping length).
4. Type of liquid being pumped (Water, acid, slurry, etc.).
5. Mounting/installation requirements.
6. Voltage, hertz and phase.

PUMP TYPES AVAILABLE



Superflo® Centrifugal Pumps

Centrifugal pumps operate at relatively low pressure. They will pass abrasives and bits of solid material without binding or appreciable wear and require minimal maintenance. Pump discharge can be restricted without damage to pump or motor. Viscosity range up to 500 SSU.

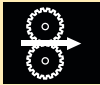

Gear Pumps

Ideal for applications where consistently high pressure is required to feed lubricants, drawing compounds, heavy viscosity oils and other fluids which are free of abrasives and scale. Viscosity range up to 5,000 SSU.



Diaphragm Pumps

Air powered, they deliver variable flow rates up to 40 GPM. Can be used for pumping a wide variety of fluids up to 10,000 CPS.



High Pressure, Multi-Stage Pumps

Designed to meet delivery requirements where high pressure is needed.

TOTAL DEVELOPED HEAD (TDH)

TDH is the total resistance against which the pump is working. This resistance is comprised of three general factors: Dynamic Head, Static Head, and Velocity Head.

1. **Dynamic Head** is the flow resistance created by friction in piping, valves, fittings and by liquid viscosity.* To derive maximum flow from a pump, use the largest piping possible and minimize any restrictive components such as 90 degree elbows, reducers or valves.
2. **Static Head** is the height to which the liquid must be raised. Note: When using the Flow Charts in the pump section, both Dynamic Head and Static Head must be included in estimating the TDH against which the pump will operate.
3. **Velocity Head** is the pressure required to accelerate the liquid to its flow velocity. This is usually a negligible factor of TDH and can be disregarded unless piping is smaller than the pump discharge and/or flow velocities are greater than 15 feet per second.

*The thicker the viscosity of a liquid, the more resistance it has to flow. Most pump viscosities throughout this catalog are stated in SSUs (Saybolt's Second Universal). 70°F water = 31 SSU. Light hydraulic oil = 350 SSU. #10 oil = 500 SSU. When using Pump flow charts, be sure to note the designated fluid viscosity.

HEAD FEET/PSI CONVERSIONS

Pump curves throughout the pump section are based on (TDH) feet of water pressure. Here are the formulas to convert head feet and pounds per square inch (PSI).

$$\text{Head feet} = \text{PSI} \times 2.31 \div \text{Specific Gravity}$$

$$\text{PSI} = \text{Head feet} \times \text{Specific Gravity} \div 2.31$$

(Specific gravity of water = 1)

MOTOR SELECTION FOR PUMPS—HOW TO ORDER

Pumps and Pumping Units are available with motors of all standard electrical characteristics. The most commonly used types are listed below with their Graymills Suffix. Other types of motors will be quoted upon request.

1. After selecting the pump desired, select the type of motor with your required electrical characteristics. All Graymills pump motors are rated for 60 Hz operation and will operate continuously within plus or minus 5% of the rated voltage. Air motors are available for many models.
2. Add the suffix letter to the base model number and also state voltage, hertz and phase when ordering.

VOLTAGE SUFFIX CHART

Suffix	A	B	E	F	Z	GAM/GAMC
Voltage	115	230	115/230	230/460	575	Air motor
Hertz	50/60	50/60	50/60	50/60	60	
Phase	1	1	1	3	3	

PUMP PERFORMANCE—50 HERTZ

RPM and Performance of standard pumps at 60 Hz will be reduced when running at 50 Hz.

SPECIAL POWER REQUIREMENTS

Graymills supplies pumps worldwide and can supply motors meeting the electrical requirements of most areas. We regularly supply the following voltages; 220 volts, 50 Hz, 1 Ph; 380 or 415 volts, 50 Hz, 3 Ph. Please consult factory for more information.

AIR MOTORS

Most Graymills pumps can be equipped with rotary air motors, which include needle valve and muffler. We recommend the use of an air pressure filter-regulator-lubricator.

SPECIAL PUMP TANK COMBINATIONS

Graymills supplies special systems to thousands of customers. We welcome your inquiry on special combinations of pumps, tanks and filters.



Superflo® Centrifugal Pumps

Graymills pumps have diverse applications and specifications. . . but they all share many common design elements and qualities that make them the industry standard. Take a look at the cut-away of the HR Series pump below. What you see is representative of the quality of our entire line of pumps and pump & tank systems.

Features, capabilities and materials vary from pump to pump. In each you'll find the Graymills constants of advanced design, construction, and reliability.

Superflo Pump Features

1. Totally enclosed NEMA standard motor with lifetime-lubricated sealed ball bearings. (Other motor options available.)
2. Rigid coupling and shaft assembly facilitates "off-the-shelf" motor replacement.
3. Each impeller shaft is custom machined and balanced right on the pump.
4. Lightweight, glass-filled Celcon impeller eliminates metal-to-metal contact. More abrasive-resistant than metal, its light weight allows shafts up to 20" long to run true without a lower bearing. Field replacements do not require balancing.
5. No seals, packings or bearings below liquid level (on most models under 20" column length).
6. Materials and coating—such as nickel plating, Teflon® coating and stainless steel—are available.

Feel free to call us if you have any questions... or if you have unique requirements that need special attention.

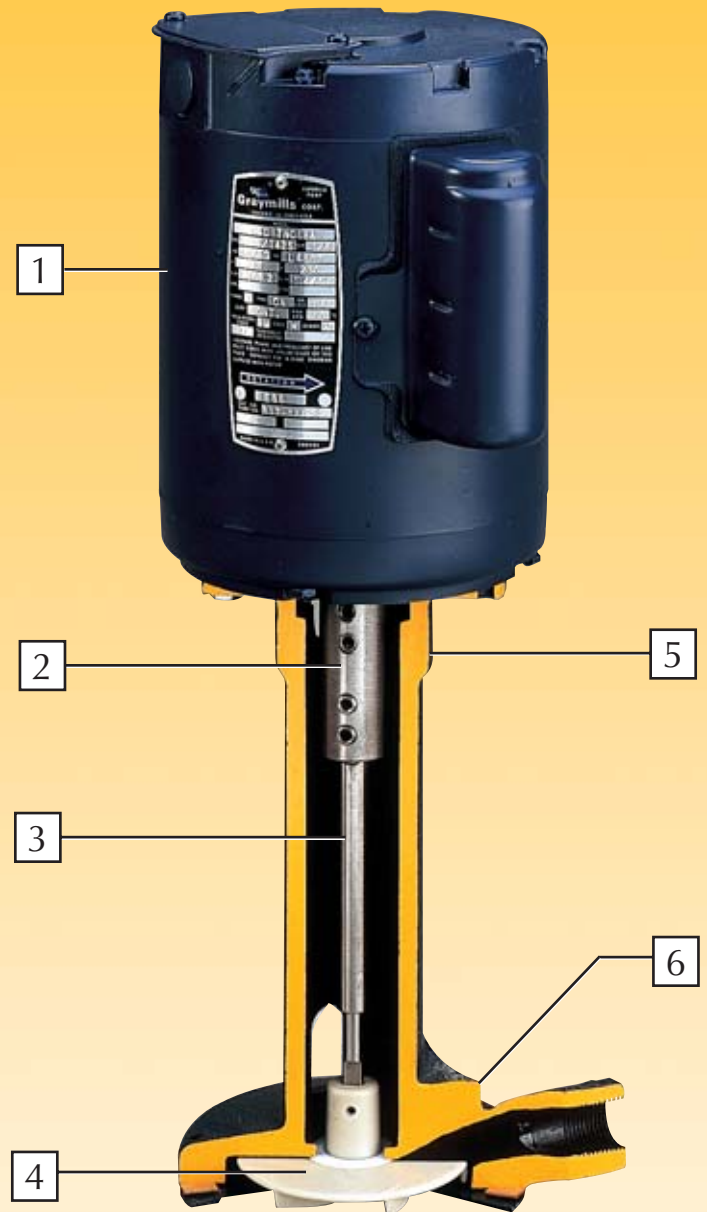

Before packing your pump for shipment, the assembler affixes a Quality Assurance label bearing his name. Responsible for tests and inspections, he is the final authority in determining that your pump meets Graymills standards.

TN Series



The TN Series offers five sizes to provide progressively higher flow rates and head pressures. Within most sizes, the high speed "H" models provide the highest head pressures. TN pumps cover a wide range of applications (no bearings or seals in the liquid except 24" and 36" lengths), including thin to heavy viscosities and liquids containing abrasives and solids. Virtually maintenance free. TN pumps can be combined with tanks to provide you with a complete, ready-to-install pumping system.



TN30 SERIES SPECIFICATIONS

Most pumps available as pump/tank combinations. See pages 25-29 or consult factory.

TN30: 1/8, 1/4 HP, 1725 RPM, 1" NPT vertical discharge. Maximum viscosity: 500 SSU

TN30H: Available in 1/2, 3/4, 1 and 1-1/2 HP, 3450 RPM, 1" NPT vertical discharge. Maximum viscosity: 500 SSU.

MATERIALS

Pump Body and Volute: Cast iron

Shaft: Carbon steel

Impeller: Double suction, Celcon

Special Materials: All TN Series pumps are available with nickel plating, Teflon® coating or stainless steel shafts for extra corrosion and abrasion resistance. Consult factory for special pricing.

TN30 Series

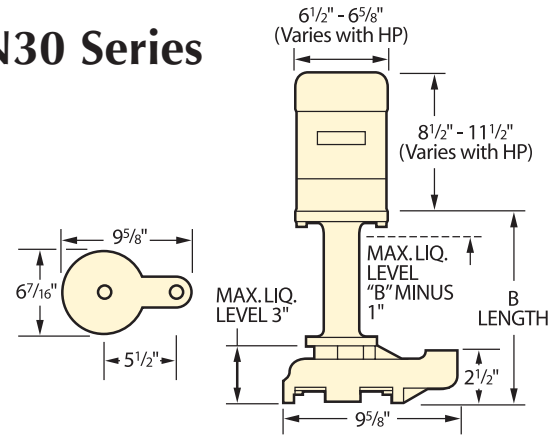

TN30/TN30H ORDER INFORMATION

B LENGTH	MODEL	HP	VOLTAGE SUFFIX
7 5/8"	TN31	1/8	F, Z, GAMC
7 5/8"	TN31	1/4	E, F, Z, GAMC
10 1/2"	TN33	1/8	F, Z, GAMC
10 1/2"	TN33	1/4	E, F, Z, GAMC
12 3/4"	TN36	1/8	F, Z, GAMC
12 3/4"	TN36	1/4	E, F, Z, GAMC
13 7/8"	TN37	1/8	F, Z, GAMC
13 7/8"	TN37	1/4	E, F, Z, GAMC
16"	TN38	1/8	F, Z, GAMC
16"	TN38	1/4	E, F, Z, GAMC
24"	TNW324	1/4	E, F, Z, GAMC
36"	TNW336	1/4	E, F, Z, GAMC
7 5/8"	TN31H	1/2, 3/4, 1, 1-1/2	E, F, Z
10 1/2"	TN33H	1/2, 3/4, 1, 1-1/2	E, F, Z
12 3/4"	TN36H	1/2, 3/4, 1, 1-1/2	E, F, Z
13 7/8"	TN37H	1/2, 3/4, 1, 1-1/2	E, F, Z

VOLTAGE SUFFIX CHART

Suffix	A	B	E	F	Z	GAM/GAMC
Voltage	115	230	115/230	230/460	575	Air motor
Hertz	50/60	50/60	50/60	50/60	60	
Phase	1	1	1	3	3	

TN30 SERIES PERFORMANCE

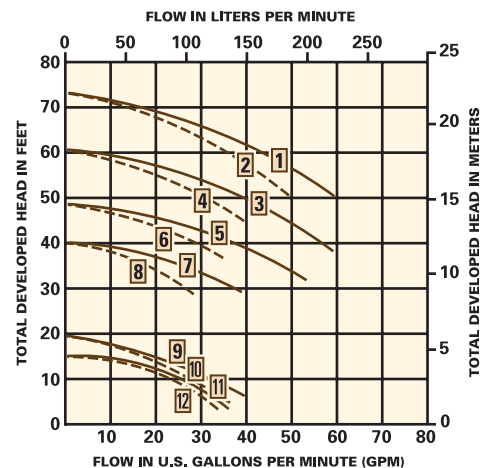

1. TN30H 1-1/2 HP water
2. TN30H 1-1/2 HP 300 SSU oil
3. TN30H 1 HP water
4. TN30H 1 HP 300 SSU oil
5. TN30H 3/4 HP water
6. TN30H 3/4 HP 300 SSU oil
7. TN30H 1/2 HP water
8. TN30H 1/2 HP 300 SSU oil
9. TN30 1/4 HP water
10. TN30 1/4 HP 300 SSU oil
11. TN30 1/8 HP water
12. TN30 1/8 HP 300 SSU oil



The TN Series offers five sizes to provide progressively higher flow rates and head pressures. Within most sizes, the high speed "H" models provide the highest head pressures. TN pumps cover a wide range of applications (no bearings or seals in the liquid except 24" and 36" lengths), including thin to heavy viscosities and liquids containing abrasives and solids. Virtually maintenance free. TN pumps can be combined with tanks to provide you with a complete, ready-to-install pumping system.

TN40/50 Series

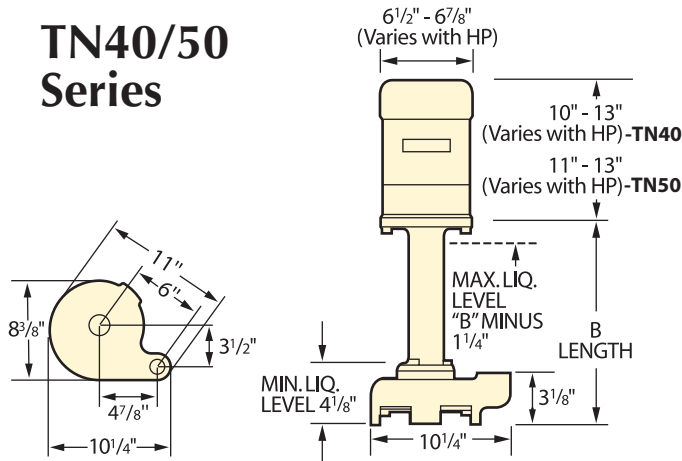

TN40 SERIES PERFORMANCE

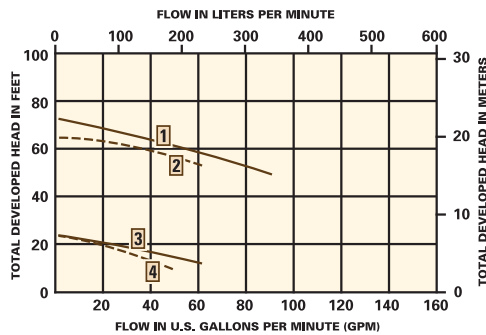

1. TN40H water
2. TN40H 300 SSU oil
3. TN40 water
4. TN40 300 SSU oil

TN50 SERIES PERFORMANCE

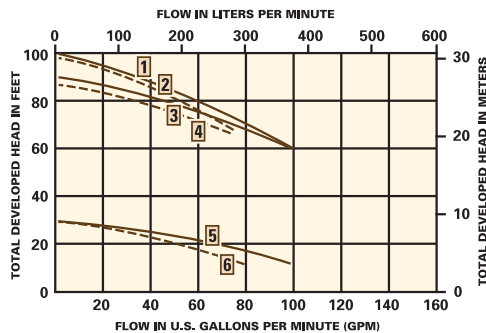

1. TN50HH water
2. TN50HH 300 SSU oil
3. TN50H water
4. TN50H 300 SSU oil
5. TN50 3/4 HP water
6. TN50 3/4 HP 300SSU oil

VOLTAGE SUFFIX CHART

Suffix	A	B	E	F	Z	GAM/GAMC
Voltage	115	230	115/230	230/460	575	Air motor
Hertz	50/60	50/60	50/60	50/60	60	
Phase	1	1	1	3	3	

TN40/50 SERIES SPECIFICATIONS

Most pumps available as pump/tank combinations. See pages 25-29 or consult factory.

TN40: 1/2 HP, 1725 RPM, 1 1/4" NPT vertical discharge. Maximum viscosity: 500 SSU.

TN40H: 2 HP, 3450 RPM, 1 1/4" NPT vertical discharge. Maximum viscosity: 500 SSU.

TN50: 3/4 HP, 1725 RPM, 1 1/4" NPT vertical discharge. Maximum viscosity: 500 SSU.

TN50H: 3 HP, 3450 RPM, 1 1/2" NPT vertical discharge. Maximum viscosity: 500 SSU.

TN50HH: The TN50HH has the same specifications as the TN50H, but with a larger diameter impeller to produce higher pressure.

MATERIALS

Pump Body and Volute: Cast iron

Shaft: Carbon steel

Impeller: Double suction, Celcon

Special Materials: All TN Series pumps are available with nickel plating, Teflon® coated or stainless steel shafts for extra corrosion and abrasion resistance. Consult factory for special pricing.

TN40/TNW40H ORDER INFORMATION

B LENGTH	MODEL	HP	VOLTAGE SUFFIX
7 7/8"	TN41	1/2	E, F, Z, GAMC
10 3/8"	TN43	1/2	E, F, Z, GAMC
12 7/8"	TN46	1/2	E, F, Z, GAMC
14 1/4"	TN47	1/2	E, F, Z, GAMC
16 3/8"	TN48	1/2	E, F, Z, GAMC
23 5/8"	TNW424	1/2	F
35 5/8"	TNW436	1/2	F
10 3/8"	TNW43H	2	F
12 7/8"	TNW46H	2	F
14 1/4"	TNW47H	2	F
16 3/8"	TNW48H	2	F
19 5/8"	TNW420H	2	F

TN50/TN50H/TN50HH ORDER INFORMATION

B LENGTH	MODEL	HP	VOLTAGE SUFFIX
10 3/8"	TN53	3/4	E, F, Z, GAMC
12 7/8"	TN56	3/4	E, F, Z, GAMC
14 1/4"	TN57	3/4	E, F, Z, GAMC
16 3/8"	TN58	3/4	E, F, Z, GAMC
23 5/8"	TNW524	3/4	E, F, Z, GAMC
10 3/8"	TNW53H	3	F
12 7/8"	TNW56H	3	F
14 1/4"	TNW57H	3	F
16 3/8"	TNW58H	3	F
19 5/8"	TNW520H	3	F
10 3/8"	TNW53HH	3	F
12 7/8"	TNW56HH	3	F
14 1/4"	TNW57HH	3	F
16 3/8"	TNW58HH	3	F
19 5/8"	TNW520HH	3	F

TN Series



The TN Series offers five sizes to provide progressively higher flow rates and head pressures. Within most sizes, the high speed "H" models provide the highest head pressures. TN pumps cover a wide range of applications (no bearings or seals in the liquid except 24" and 36" lengths), including thin to heavy viscosities and liquids containing abrasives and solids. Virtually maintenance free. TN pumps can be combined with tanks to provide you with a complete, ready-to-install pumping system.



TN60/70 SERIES SPECIFICATIONS

Most pumps available as pump/tank combinations. See pages 25-29 or consult factory.

TN60: 1 HP, 1725 RPM, 1 1/2" NPT vertical discharge. Maximum viscosity: 500 SSU.

TN70: 1-1/2 HP, 1725 RPM, 2" NPT vertical discharge. Maximum viscosity: 500 SSU.

MATERIALS

Pump Body and Volute: Cast iron

Shaft: Carbon steel

Impeller: Double suction, Celcon

Special Materials: All TN Series pumps are available with nickel plating, Teflon® coated or stainless steel shafts for extra corrosion and abrasion resistance. Consult factory for special pricing.

TN60/70 Series

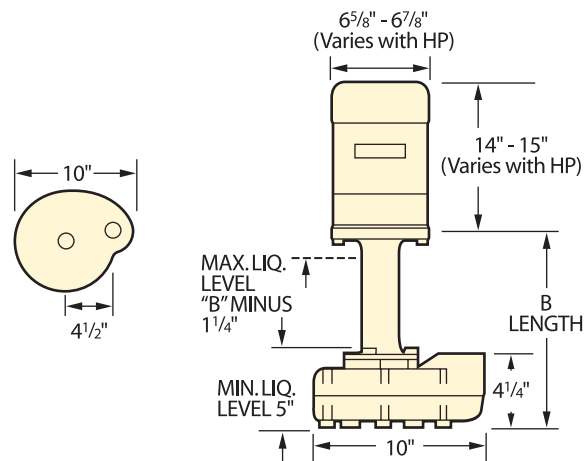

TN60/70 ORDER INFORMATION

B LENGTH	MODEL	HP	VOLTAGE SUFFIX
11 3/8"	TN63	1	F, Z
15"	TNW67	1	F, Z
17 1/4"	TNW68	1	F, Z
24"	TNW624	1	F, Z
11 3/8"	TN73	1-1/2	F, Z
15"	TNW77	1-1/2	F, Z
17 1/4"	TNW78	1-1/2	F, Z
24"	TNW724	1-1/2	F, Z

VOLTAGE SUFFIX CHART

Suffix	A	B	E	F	Z	GAM/GAMC
Voltage	115	230	115/230	230/460	575	Air motor
Hertz	50/60	50/60	50/60	50/60	60	
Phase	1	1	1	3	3	

TN60/70 SERIES PERFORMANCE

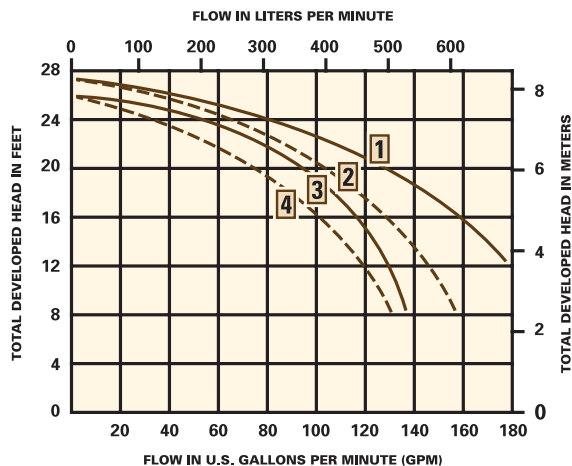

1. TN70 water
2. TN70 300 SSU oil
3. TN60 water
4. TN60 300 SSU oil



Agitator Series

Agitator pumps are designed for use with liquids containing solids which must be kept in suspension or require constant circulation to maintain uniform viscosity. A port in the pump volute bypasses a jet stream of fluid to "stir" tank contents. A port plug is furnished so that the bypass can be eliminated when tank agitation is not desired.



TNRT/TNRSS Series

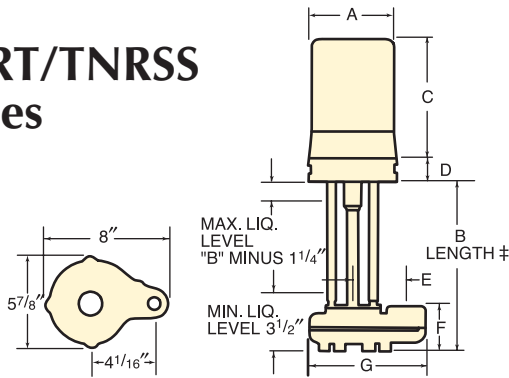

‡ See Order Information Chart on the right hand column of this page for B Length Dimensions

MODEL	A*	C Max.	D	E	F	G
TNRT30	6 1/2"	8 1/2"	1 5/16"	5 1/2"	2 1/2"	9 5/8"
TNRT30H	6 1/2"	11 1/2"	1 5/16"	5 1/2"	2 1/2"	9 5/8"
TNRT40	6 1/2"	10"	1 5/16"	6"	3 1/2"	10 1/4"
TNRT40H	6 1/2"	13"	1 5/16"	6"	3 1/2"	10 1/4"
TNRSS30	6 1/2"	8 1/2"	1 5/16"	4 1/16"	2 9/16"	8"
TNRSS30H	6 1/2"	11 1/2"	1 5/16"	4 1/16"	2 9/16"	8"

*Shroud on fan-cooled motors (H models) increases this dimension approx. 3/4".

TNRT/TNRSS SERIES PERFORMANCE

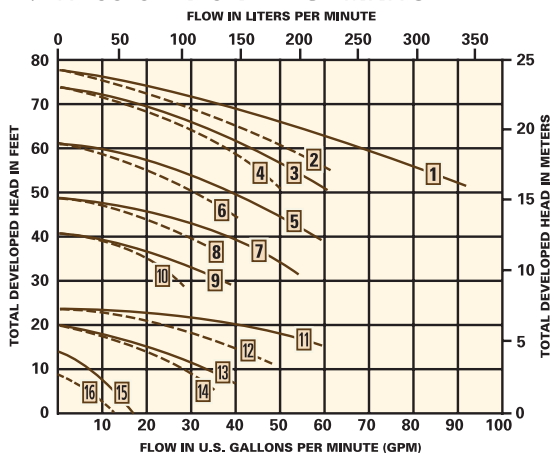

1. TNRT40H 2 HP (water)
2. TNRT40H 2 HP (300SSU oil)
3. TNRT/TNRSS30H 1-1/2 HP (water)
4. TNRT/TNRSS30H 1-1/2 HP (300SSU oil)
5. TNRT/TNRSS30H 1 HP (water)
6. TNRT/TNRSS30H 1 HP (300SSU oil)
7. TNRT/TNRSS30H 3/4 HP (water)
8. TNRT/TNRSS30H 3/4 HP (300SSU oil)
9. TNRT/TNRSS30H 1/2 HP (water)
10. TNRT/TNRSS30H 1/2 HP (300SSU oil)
11. TNRT40 1/2 HP (water)
12. TNRT40 1/2 HP (300SSU oil)
13. TNRT30 1/4 & 1/2 HP (water)
14. TNRT30 1/4 & 1/2 HP (300SSU oil)
15. HRTG45 1/8 HP (water)
16. HRTG45 1/8 HP (300SSU oil)

AGITATOR SERIES SPECIFICATIONS

Available in both closed column (HRTG model) and easy-to-clean Tri-Rod design (TNR Models). In order to extend motor life, rod style pumps are equipped with a vapor diffuser which prevents vapors from diluting the motor bearing grease. Most pumps available as pump/tank combinations. See pages 25-29 or consult factory.

HRTG: 1/8 HP, 1725 RPM, 1/2" NPT horizontal discharge. Maximum viscosity: 500 SSU. For dimensional data, see HR45, page 10.

TNRT30: 1/4 or 1/2 HP, 1725 RPM, 3/4" NPT vertical discharge. Maximum viscosity: 500 SSU.

TNRT30H: 1/2, 3/4, 1, 1-1/2 HP, 3450 RPM, 1" NPT vertical discharge. Maximum viscosity: 500 SSU.

TNRT40: 1/2 HP, 1725 RPM, 1" NPT vertical discharge. Maximum viscosity: 500 SSU.

TNRT40H: 2 HP, 3450 RPM, 1 1/4" NPT vertical discharge. Maximum viscosity: 500 SSU.

MATERIALS*

HRTG: Pump Body: Teflon®-coated cast iron. **Shaft:** Carbon steel or optional stainless steel. **Impeller:** Celcon.

TNRT SERIES: Volute: Teflon®-coated cast iron. **Shaft and Rods:** 416 Series stainless steel. **Impeller:** Celcon.

TNRSS SERIES: Shaft, Rods and Volute: 316 Series stainless steel. **Impeller:** Chemically inert Ryton.

* Nickel plating available—consult factory

AGITATOR ORDER INFORMATION

B LENGTH	MODEL	HP	VOLTAGE SUFFIX
----------	-------	----	----------------

TEFLON® COATED CAST IRON MODELS

8"	HRTG45	1/8	E, F, GAM
7 5/8"	TNRT31	1/4, 1/2	E, F, GAMC
10 1/8"	TNRT33	1/4, 1/2	E, F, GAMC
12 3/4"	TNRT36	1/4, 1/2	E, F, GAMC
13 7/8"	TNRT37	1/4, 1/2	E, F, GAMC
16"	TNRT38	1/4, 1/2	E, F, GAMC
36"	TNRT336**	1/4, 1/2	E, F, GAMC
13"	TNRT46	1/2	E, F, GAMC
16 3/4"	TNRT48	1/2	E, F, GAMC
36"	TNRT436**	1/2	E, F, GAMC
12 3/4"	TNRT36H	1/2, 3/4, 1, 1 1/2	E, F
13"	TNRT46H	2	E, F

STAINLESS STEEL MODELS

7 5/8"	TNRSS31	1/4, 1/2	E, F, GAMC
10 1/8"	TNRSS33	1/4, 1/2	E, F, GAMC
12 3/4"	TNRSS36	1/4, 1/2	E, F, GAMC
13 7/8"	TNRSS37	1/4, 1/2	E, F, GAMC
16"	TNRSS38	1/4, 1/2	E, F, GAMC
10 1/8"	TNRSS33H	1/2, 3/4, 1, 1 1/2	E, F
12 3/4"	TNRSS36H	1/2, 3/4, 1, 1 1/2	E, F

**Note: Due to its length, this pump has a lower hardened bushing and cannot be used to pump liquids containing abrasives.

See page 4 for voltage information.

HR Series



HR Series pumps are widely used for circulating thin liquids and abrasives. Impellers are open type. No bearings, packings or seals below liquid level.

HR SERIES SPECIFICATIONS

HR Series pumps feature many of the same durable construction features of our TN Series pumps, but in a size more appropriate to applications requiring a smaller size and less flow. Most pumps available as pump/tank combinations. See pages 25-29 or consult factory.

HR35: 1/25 HP, 1500 RPM, 1/2" NPT horizontal discharge. Maximum viscosity: 150 SSU.

HR45/49: 1/8 HP, 1725 RPM, 1/2" NPT horizontal discharge. Maximum viscosity: 500 SSU. HR45 pump is available as an Agitator style pump. See HRTG Model on page 9.

MATERIALS

Pump Body and Volute: Cast iron

Shaft: Carbon steel

Impeller: Celcon

Special Materials: All HR Series pumps are available with nickel plating, Teflon® coating or stainless steel shafts for extra corrosion and abrasion resistance. Consult factory for special pricing.

HR Series

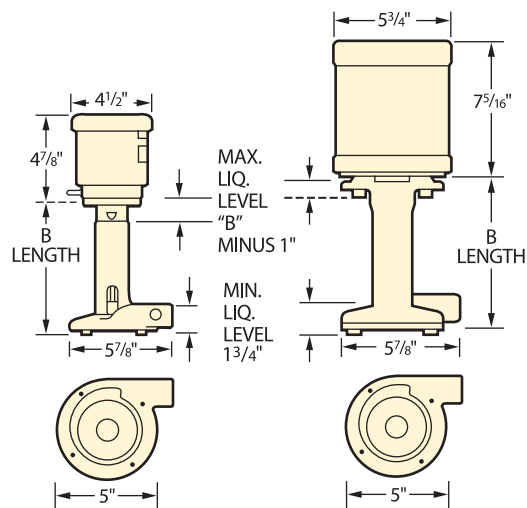

HR35

HR45/49

HR ORDER INFORMATION

B LENGTH	MODEL	HP	VOLTAGE SUFFIX
8"	HR35	1/25	A, B, GAM
8"	HR45	1/8	A, B, E, F, GAM
9"	HR49	1/8	A, B, E, F, GAM

VOLTAGE SUFFIX CHART

Suffix	A	B	E	F	Z	GAM/GAMC
Voltage	115	230	115/230	230/460	575	Air motor
Hertz	50/60	50/60	50/60	50/60	60	
Phase	1	1	1	3	3	

HR SERIES PERFORMANCE

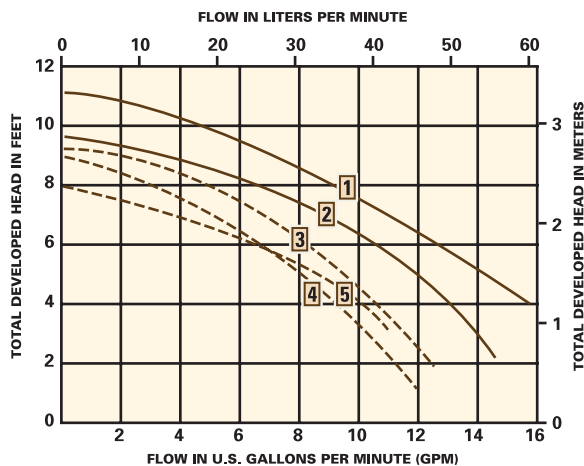

1. HR45/49 water
2. HR35 water
3. HR45/49 100 SSU oil
4. HR45/49 300 SSU oil
5. HR35 100 SSU oil



FM Series

FM Series pumps are compact, yet offer the performance and dependability of larger pumps. Graymills' volute design enables FM Series pumps to pump down to an extremely low level. Discharge is above the integral mounting flange.



FM Series

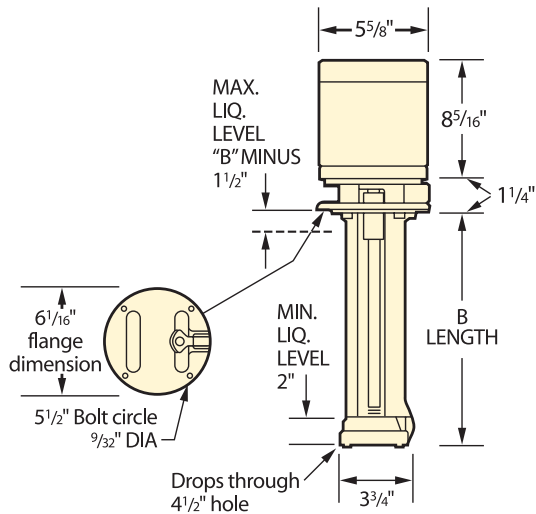

FM SERIES SPECIFICATIONS

These pumps will drop through a 4 1/2" hole supported by their integral mounting flange. Discharge is above the mounting flange. Discharge diameter and maximum viscosity for each pump are listed below. Pump performance and available motor voltages are shown at left. Most pumps available as pump/tank combinations. See pages 25-29 or consult factory.

FM60: 1/8 HP, 3450 RPM, 1/2" NPT horizontal discharge. Maximum viscosity: 500 SSU.

FM70: 1/4 HP, 3450 RPM, 1/2" NPT horizontal discharge. Maximum viscosity: 500 SSU.

MATERIALS

Pump Body and Volute: Cast iron

Shaft: Carbon steel

Impeller:

FM60: Celcon

FM70: Aluminum

Special materials: All FM Series pumps are available with nickel plating, Teflon® coating or stainless steel shafts for extra corrosion and abrasion resistance. Consult factory for special pricing.

FM ORDER INFORMATION

B LENGTH	MODEL	HP	VOLTAGE SUFFIX
3 1/2"	FM63H	1/8	E, F, Z
6"	FM66H	1/8	E, F, Z
8 1/2"	FM68H	1/8	E, F, Z
12 1/2"	FM612H	1/8	E, F, Z
3 1/2"	FM73H	1/4	F, Z
6"	FM76H	1/4	F, Z
8 1/2"	FM78H	1/4	F, Z
12 1/2"	FM712H	1/4	F, Z

FM SERIES PERFORMANCE

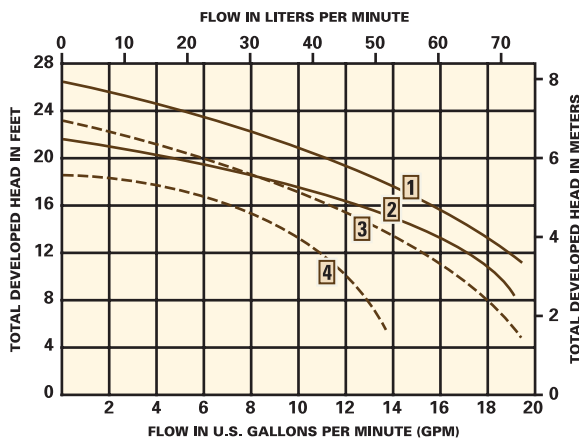

1. FM70H water
2. FM60H water
3. FM70H 300 SSU oil
4. FM60H 300 SSU oil

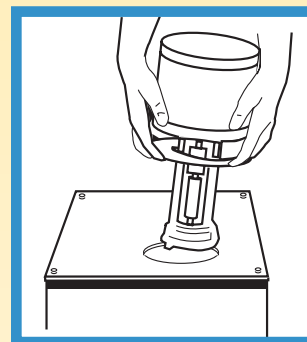

Easy Mount

The FM Series pumps feature an integral mounting flange. Consult factory for variations in mounting.

Pump drops through 4-1/2" hole and mounts on integral flange.

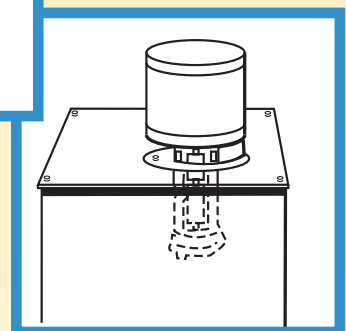

VOLTAGE SUFFIX CHART

Suffix	A	B	E	F	Z	GAM/GAMC
Voltage	115	230	115/230	230/460	575	Air motor
Hertz	50/60	50/60	50/60	50/60	60	
Phase	1	1	1	3	3	



HP Series



HP Series pumps are designed for reliable, heavy duty, high flow pumping of industrial slurries, abrasives, and other fluids. Interchangeability of motors and impellers allows you to specify the combination that best meets your needs.

HP SERIES SPECIFICATIONS

Pump performance can be varied by specifying a different motor and impeller size. Use the performance chart below to identify the performance curves required by your application. Performance Curves 1 through 4 identify the pump performance for each of 4 impeller options (A, B, C, D). Diagonal lines express horsepower (HP). Once you have selected the performance parameter required, the Order Information chart at right allows you to determine the horsepower/impeller combination.

Optional mounting accessories are available on page 34 for HP Series pumps. Most pumps available as pump/tank combinations. See pages 25-29 or consult factory.

All Models: 230/460V, 60/50 Hz, 3 Ph motors. 2 1/2" NPT horizontal discharge. Maximum viscosity: 500 SSU.

HP500: 5 HP, 3450 RPM

HP750: 7-1/2 HP, 3450 RPM

HP1000: 10 HP, 3450 RPM

MATERIALS

Pump Body and Volute: Cast iron

Shaft: Carbon steel

Impeller: Double suction, Celcon

Special Materials: All HP Series pumps are available with nickel plating, Teflon® coating or stainless steel shafts for extra corrosion and abrasion resistance. Consult factory for special pricing.

VOLTAGE SUFFIX CHART

Suffix	A	B	E	F	Z	GAM/GAMC
Voltage	115	230	115/230	230/460	575	Air motor
Hertz	50/60	50/60	50/60	50/60	60	
Phase	1	1	1	3	3	

HP Series

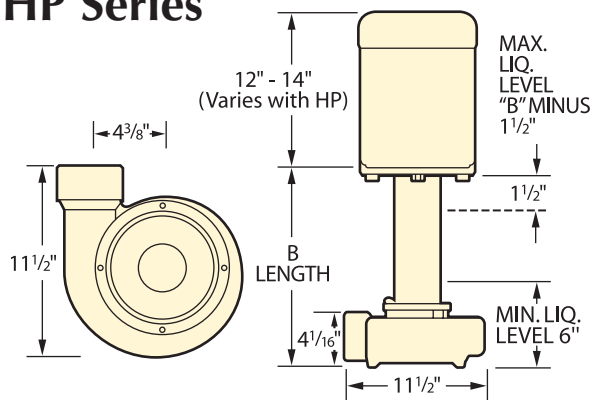

HP ORDER INFORMATION

B LENGTH	IMPELLER SIZE (Dia.)			
	5" (A)	5 1/2" (B)	6" (C)	6 1/2" (D)
5 HP MODELS				
15"	HP515HA-F	HP515HB-F	HP515HC-F	
24"	HP524HA-F	HP524HB-F	HP524HC-F	
7-1/2 HP MODELS				
15"		HP7.515HB-F	HP7.515HC-F	HP7.515HD-F
24"		HP7.524HB-F	HP7.524HC-F	HP7.524HD-F
10 HP MODELS				
15"			HP1015HC-F	HP1015HD-F
24"			HP1024HC-F	HP1024HD-F

HP SERIES PERFORMANCE

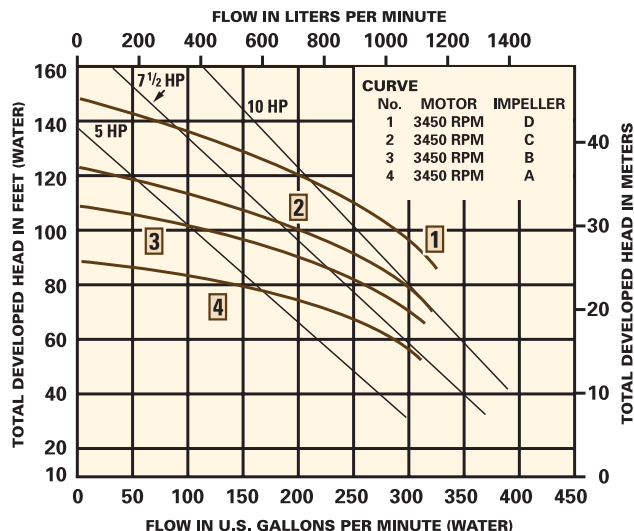

To use the chart, locate your required operating point (intersection GPM & TDH). If the operating point is between two curves, select the higher of the two. The required motor horsepower will be shown by the first diagonal line to the right of the operating point.

HSP Series

Performance, reliability, quality of construction and premium materials are features that will make the HSP your choice in pumps. HSP pumps feature a seal-less design to eliminate leaking and reduce maintenance time and cost over the life of the pump.



HSP Series

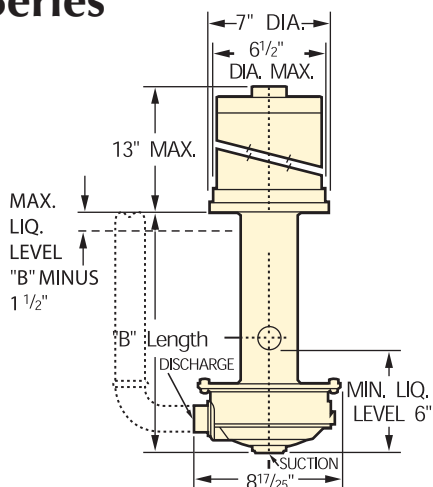

HSP SERIES SPECIFICATIONS

HSP pumps provide high performance capabilities with the reliability of stainless steel construction at an affordable price. For the cost of cast iron, you can upgrade your existing pumps to this series of stainless steel immersion pumps. The durable, fabricated stainless steel construction resists corrosion and is suitable for use in a variety of chemical environments. Select 14" or the 24" for deeper tanks without requiring use of a tailpipe.

These powerful pumps deliver up to 175 GPM @ 55 TDH to meet the most demanding fluid pumping needs. This stainless steel pump is ideal for a multitude of applications where conventional cast iron pumps are not suitable or where corrosion resistance is necessary.

All Models: 230/460V, 60/50Hz, 3 Ph motors, Horizontal Discharge. Maximum viscosity: 400 SSU.

HSP115: 1-1/2 HP, TEFC, 1 1/4" discharge x 1 1/2" suction

HSP120: 2 HP, TEFC, 1 1/4" discharge x 1 1/2" suction

HSP130: 3 HP, TEFC, 1 1/4" discharge x 1 1/2" suction

HSP150: 5 HP, ODP, 1 1/4" discharge x 1 1/2" suction

HSP230: 3 HP, TEFC, 1 1/2" discharge x 2" suction

HSP250: 5 HP, ODP, 1 1/2" discharge x 2" suction

MATERIALS

Pump Body and Volute: Stainless steel

Impeller, Column and Shaft: Stainless steel

Casing and Impeller O-Rings: Viton

Bushing: Stainless steel

HSP ORDER INFORMATION

B LENGTH	MODEL	HP	MOTOR VOLTAGE
14"	HSP115-F14	1-1/2	F, Z
24"	HSP115-F24	1-1/2	F, Z
14"	HSP120-F14	2	F, Z
24"	HSP120-F24	2	F, Z
14"	HSP130-F14	3	F, Z
24"	HSP130-F24	3	F, Z
14"	HSP150-F14	5	F, Z
24"	HSP150-F24	5	F, Z
14"	HSP230-F14	3	F, Z
24"	HSP230-F24	3	F, Z
14"	HSP250-F14	5	F, Z
24"	HSP250-F24	5	F, Z

VOLTAGE SUFFIX CHART

Suffix	A	B	E	F	Z	GAM/GAMC
Voltage	115	230	115/230	230/460	575	Air motor
Hertz	50/60	50/60	50/60	50/60	60	
Phase	1	1	1	3	3	

HSP100 SERIES PERFORMANCE

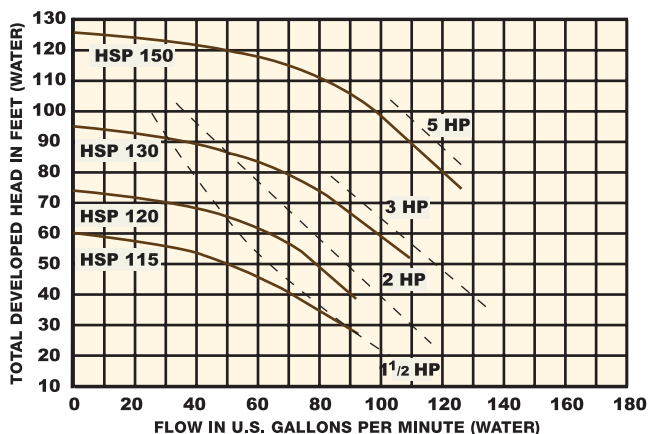

HSP200 SERIES PERFORMANCE

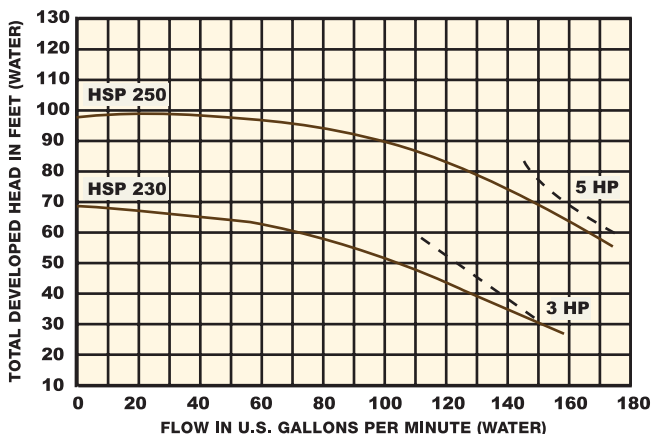

VP Series

VP Series pumps are specially designed to withstand highly abrasive and/or caustic liquids. The high strength glass-filled thermoplastic construction of these pumps provides a cost-effective alternative to brass or stainless steel.

VP SERIES SPECIFICATIONS

All VP Series pumps have permanently lubricated sealed ball bearing motors with guards in pump column to protect motor from splashing and vapors. A labyrinth chamber above the volute eliminates splashing at low liquid levels. Celcon, a tough glass-filled thermoplastic combining high mechanical strength, stiffness and stability through a broad range of temperatures, is used in all VP Series pumps and impellers. Pump performance, maximum viscosity and motors available for each model are shown below. Most pumps available as pump/tank combinations. See pages 25-29 or consult factory.

All Models: 5/8" O.D. slip-on vertical discharge.

VP20: 1/25 HP, 1550 RPM, fan cooled, overload protection. Maximum viscosity: 250 SSU.

VP30: 1/15 HP, 3000 RPM, fan cooled, overload protection. Maximum viscosity: 250 SSU.

VP40: Similar to VP30, but larger impeller delivers higher flow rate. Maximum viscosity: 250 SSU.

VP50: 1/8 HP, 3450 RPM electric or 1/4HP air motor. Maximum viscosity: 400 SSU.

MATERIALS

Pump Body, Volute and Impeller: Celcon

Shaft: VPJ models, 416 stainless steel
VPM models, 316 stainless steel

CONSTRUCTION FEATURES

- Hi-strength heavy wall pump body (choice of "B" lengths 5", 8" and 10")
- Exclusive motor guard assembly to provide maximum protection against splash and vapor
- Labyrinth chamber for fast priming and low level liquid operation
- Molded plastic intake screen
- One piece molded 6 vane impeller pre-balanced for smooth efficient operation
- Stainless steel fasteners

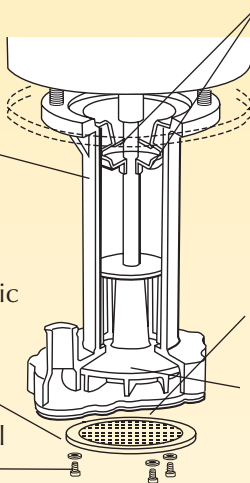

VP Series

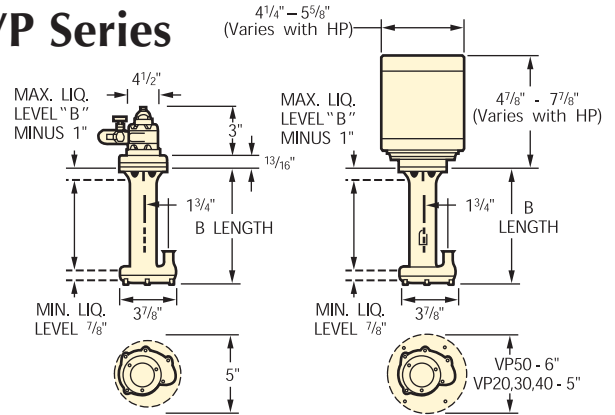

Air Motor

Electric Motor

VP ORDER INFORMATION

B LENGTH	MODEL	HP	VOLTAGE SUFFIX
5"	VPJ25	1/25	A, B
5"	VPJ35	1/15	A, B
8"	VPJ38	1/15	A, B
10"	VPJ310	1/15	A, B
5"	VPM35	1/15	A, B
8"	VPM38	1/15	A, B
10"	VPM310	1/15	A, B
5"	VPJ45	1/15	A, B
8"	VPJ48	1/15	A, B
10"	VPJ410	1/15	A, B
5"	VPM45	1/15	A, B
8"	VPM48	1/15	A, B
10"	VPM410	1/15	A, B
5"	VPJ55	1/8	A, B, F, GAM
8"	VPJ58	1/8	A, B, F, GAM
10"	VPJ510	1/8	A, B, F, GAM
5"	VPM55	1/8	A, B, F, GAM
8"	VPM58	1/8	A, B, F, GAM
10"	VPM510	1/8	A, B, F, GAM

VP SERIES PERFORMANCE

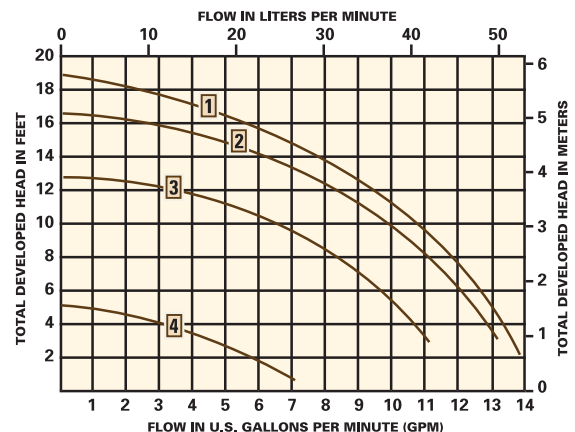

1. VP50 Series, 1/8 HP, water
2. VP40 Series, 1/15 HP, water
3. VP30 Series, 1/15 HP, water
4. VP20 Series, 1/25 HP, water



LV Series

LV Series pumps are designed with stainless steel columns and shafts, and industrial grade thermoplastic volutes and impellers, to withstand corrosive environments, while delivering high volume and high head performance with minimal horsepower requirements. Interchangeability of motors and impellers allows you to specify the combination which best meets your needs.



LV Series

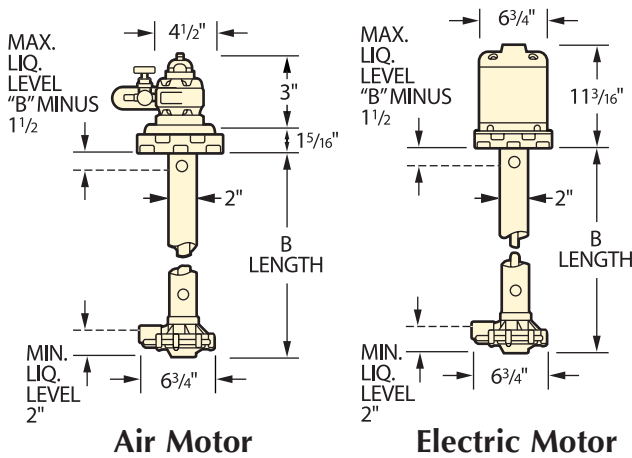

LV SERIES SPECIFICATIONS

Celcon, a tough glass-filled thermoplastic combining high mechanical strength, stiffness and stability through a broad range of temperatures, is used in all LV Series pumps and impellers. It has excellent abrasion and chemical resistance and can be used to pump water up to 170° F.

All models include vapor diffusers to help isolate the motor and permit airflow created by shaft rotation to diffuse any harmful vapors that may shorten bearing life.

Electric motor LV models with "B" lengths of 18¹/₄" or more have a lower shaft support consisting of a carbon bushing and stainless steel sleeve. Optional mounting accessories are available on page 34 for LV Series pumps.

Most pumps available as pump/tank combinations. See pages 25-29 or consult factory.

All Models: 3/4" NPT horizontal discharge. Maximum viscosity: 300 SSU.

LV20: 1/8 HP, 1725 RPM

LV40: 1/3 HP, 3450 RPM

LV50: 1/2 HP, 3450 RPM

LV60: 3/4 HP, 3450 RPM

LV70: 1 HP, 3450 RPM

NOTE: All LV available in a 0-3000 RPM air motor. Flow rates are dependent upon air flow and can be fine tuned to your application.

MATERIALS

Pump Column: 316 stainless steel

Volute: Celcon

Shaft: 316 stainless steel

Impeller: Celcon

VOLTAGE SUFFIX CHART

Suffix	A	B	E	F	Z	GAM/GAMC
Voltage	115	230	115/230	230/460	575	Air motor
Hertz	50/60	50/60	50/60	50/60	60	
Phase	1	1	1	3	3	

LV ORDER INFORMATION

B LENGTH	1/8 HP	1/3 HP	1/2 HP	3/4 HP	1 HP
8 ⁵ / ₈ "	LVM21	LVM41	LVM51	LVM61	LVM71
10 ⁷ / ₈ "	LVM22	LVM42	LVM52	LVM62	LVM72
12 ¹ / ₂ "	LVM23	LVM43	LVM53	LVM63	LVM73
18 ¹ / ₄ "	LVM24	LVM44	LVM54	LVM64	LVM74
24"	LVM25	LVM45	LVM55	LVM65	LVM75
34"	LVM27	LVM47	LVM57	LVM67	LVM77
VOLTAGE SUFFIX	A, B, F, GAM	A, B, F, GAM	A, B, F, GAM	A, B, F, GAM	E, F, GAM

LV SERIES PERFORMANCE

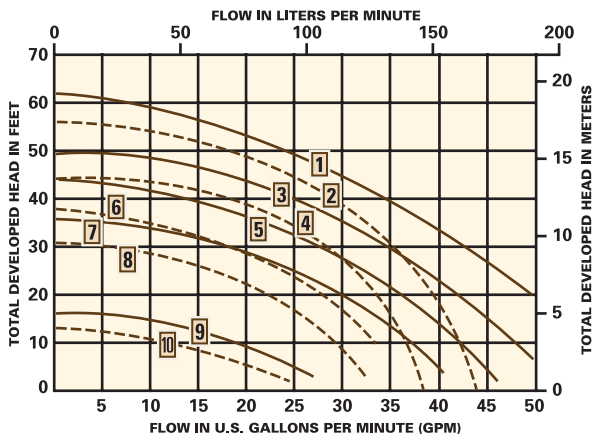

- LV70 Series, 1 HP, water
- LV70 Series, 1 HP, 250 SSU oil
- LV60 Series, 3/4 HP, water
- LV60 Series, 3/4 HP, 250 SSU oil
- LV50 Series, 1/2 HP, water
- LV50 Series, 1/2 HP, 250 SSU oil
- LV40 Series, 1/3HP, water
- LV40 Series, 1/3HP, 250 SSU oil
- LV20 Series, 1/8 HP, water
- LV20 Series, 1/8 HP, 250 SSU oil

IMV Series

IMV models are dependable, economical replacements for immersion pumps commonly supplied as original equipment on machine tools. No bearings, seals, or packing are immersed in liquid, making them ideal for pumping liquids containing fine contaminants.

IMV SERIES SPECIFICATIONS

IMV Series immersion pumps feature totally enclosed motors with sealed, permanently lubricated bearings. Discharge information is provided below. Most pumps available as pump/tank combinations. See pages 25-29 or consult factory.

All Models: Maximum viscosity: 500 SSU.

IMV08: 1/8 HP, 3450 RPM, 3/8" NPT horizontal discharge above integral mounting flange.

IMV25: 1/4 HP, 3450 RPM, 1/2" NPT horizontal discharge above integral mounting flange.

IMV50: 1/2 HP, 3450 RPM, 3/4" NPT horizontal discharge above integral mounting flange.

IMV75: 3/4 HP, 3450 RPM, 1" NPT horizontal discharge above integral mounting flange.

IMV100: 1 HP, 3450 RPM, 1" NPT horizontal discharge above integral mounting flange.

MATERIALS

Pump Body and Volute: Cast iron

Shaft: Carbon steel

Impeller: IMV08 and IMV25, plastic
IMV50, 75 and 100, aluminum

IMV Series (Immersion Style)

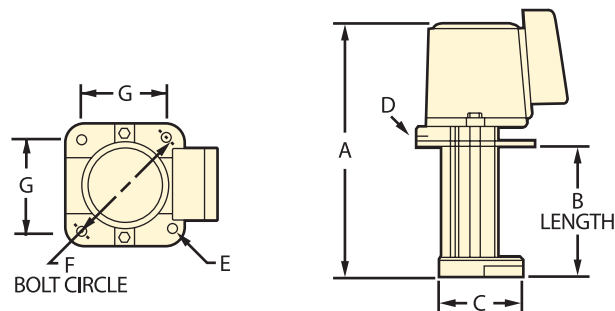

IMV DIMENSIONS

MODEL	A	B Length	C	D	E	F	G
IMV08	11 3/4"	6"	3 1/2"	3/8"	5/16"	5"	3 17/32"
IMV25	14 5/8"	7"	4 3/4"	1/2"	5/16"	6 3/8"	4 3/8"
IMV50	17 7/8"	9 1/2"	5 5/16"	3/4"	5/16"	6 3/4"	4 3/4"
IMV75	20 1/2"	11"	6"	1"	5/16"	7 5/16"	5 1/8"
IMV100	20 1/2"	11"	6"	1"	5/16"	7 5/16"	5 1/8"

Note: When ordering a replacement pump, be sure to check the dimensions of the pump you are replacing to get the most accurate pump fit.

IMV ORDER INFORMATION

B LENGTH	MODEL	HP (KW)	MAX FLOW	VOLTAGE SUFFIX
6"	IMV08	1/8 (.09)	10 GPM	E, F
7"	IMV25	1/4 (.19)	20 GPM	E, F
9 1/2"	IMV50	1/2 (.37)	35 GPM	E, F
11"	IMV75	3/4 (.56)	45 GPM	F
11"	IMV100	1 (.75)	50 GPM	F

VOLTAGE SUFFIX CHART

Suffix	A	B	E	F	Z	GAM/GAMC
Voltage	115	230	115/230	230/460	575	Air motor
Hertz	50/60	50/60	50/60	50/60	60	
Phase	1	1	1	3	3	

IMV SERIES PERFORMANCE

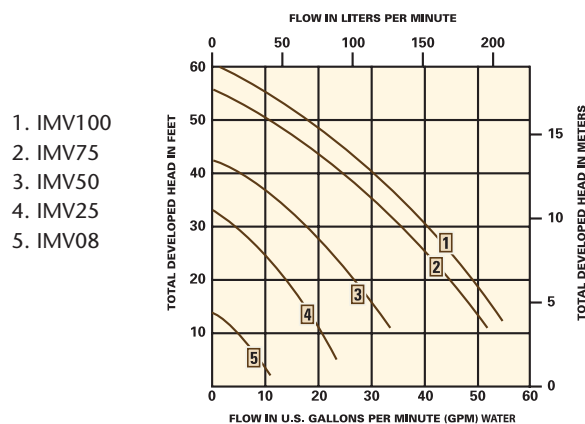

CROSS REFERENCE CHART FOR IMMERSION-STYLE PUMPS

GRAYMILLS	GUSHER	AMT	TEEL/DAYTON	FUJI	OLD FUJI#	MITSUBISHI	TOSHIBA	HITACHI	YASUKAWA
IMV08	VBV-18	534A-95	4RC28	VKP-043A	VKP-032A	NQ-60J	OPF-60M	CPD-041	VFPC-01M
IMV08		534B-95	4XZ23	VKP-043A	VKP-041A			CPD-063	VFPC-01DL
IMV08					VKP-051A				VFPC-06D1F
IMV25	VBV-14	535A-95	4RC29	VKP-063A	VKP-061A	NQ-100J	OPF-100M	CPD-103	VFPC-100
IMV25		535B-95	4XZ24	VKP-073A	VKP-071A	NQ-180J	OPF-180M	CPD-183	VFPC-180JF
IMV50	VBV-12	536A-95	4XZ25	VKP-083A	VKP-071A	NQ-180J	OPF-180M	CPD-183	VFPC-180JF
IMV50					VKP-081A	NQ-250J	OPF-250M	CPD-253	VFPC-250JF
IMV75	VBV-34	537A-95	4XZ26	VKP-093A	VKP-091A	NQ-400J	OPF-400M	CPD-403	VFPC-400JF
IMV100	VBV-10	537B-95	4XZ27		VKP-112A				VFPC-750
IMV100					VKS-113A				VFPC-170MM

IMS Series

IMS models are dependable, economical replacements for suction pumps commonly supplied as original equipment on machine tools. They should not be used to circulate fluids containing fine contaminants. Not recommended for applications requiring the circulation of liquids containing large amounts of foreign matter.



IMS Series (Suction Style)

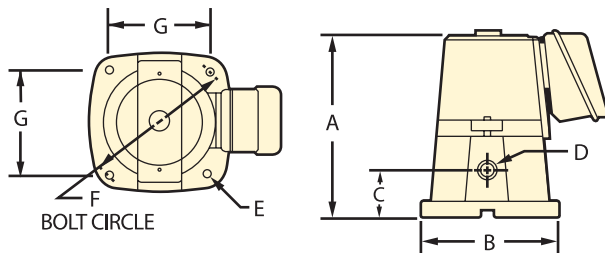

IMS SERIES SPECIFICATIONS

All motors are completely protected from soil and dust, and feature permanently lubricated, sealed bearings. Motors larger than 1/4 HP are fan cooled. With a maximum 2 ft. suction lift, IMS Series suction style pumps may be mounted above liquid level as well as other locations remote from the tank. Discharge information, pump performance and available motors are shown below.

All Models: Maximum viscosity: 500 SSU.

IMS08: 1/8 HP, 3450 RPM, 3/8" NPT horizontal discharge above integral mounting flange.

IMS25: 1/4 HP, 3450 RPM, 3/4" NPT horizontal discharge above integral mounting flange.

IMS50: 1/2 HP, 3450 RPM, 3/4" NPT horizontal discharge above integral mounting flange.

IMS75: 3/4 HP, 3450 RPM, 1" NPT horizontal discharge above integral mounting flange.

IMS100: 1 HP, 3450 RPM, 1" NPT horizontal discharge above integral mounting flange.

MATERIALS

Pump Body and Volute: Cast iron

Shaft: Carbon steel

Impeller: IMS08 and IMS25, plastic
IMS50, 75 and 100, aluminum

IMS ORDER INFORMATION

MODEL	HP (KW)	MAX FLOW	VOLTAGE SUFFIX
IMS08	1/8 (.09)	9.5 GPM	E, F
IMS25	1/4 (.19)	20 GPM	E, F
IMS50	1/2 (.37)	32 GPM	E, F
IMS75	3/4 (.56)	43 GPM	F
IMS100	1 (.75)	48 GPM	F

VOLTAGE SUFFIX CHART

Suffix	A	B	E	F	Z	GAM/GAMC
Voltage	115	230	115/230	230/460	575	Air motor
Hertz	50/60	50/60	50/60	50/60	60	
Phase	1	1	1	3	3	

IMS DIMENSIONS

MODEL	A	B	C	D	E	F	G
IMS08	6 7/8"	5 1/2"	1 5/8"	1/2"	5/16"	5 1/2"	3 7/8"
IMS25	9"	7 3/8"	2 1/8"	3/4"	5/16"	7 1/4"	5 1/8"
IMS50	10 1/4"	7 3/8"	2 1/8"	3/4"	5/16"	8 7/16"	5 31/32"
IMS75	11 3/4"	8"	2 1/2"	1"	5/16"	8 5/8"	6 3/32"
IMS100	11 3/4"	8"	2 1/2"	1"	5/16"	8 5/8"	6 3/32"

Note: When ordering a replacement pump, be sure to check the dimensions of the pump you are replacing to get the most accurate pump fit.

IMS SERIES PERFORMANCE

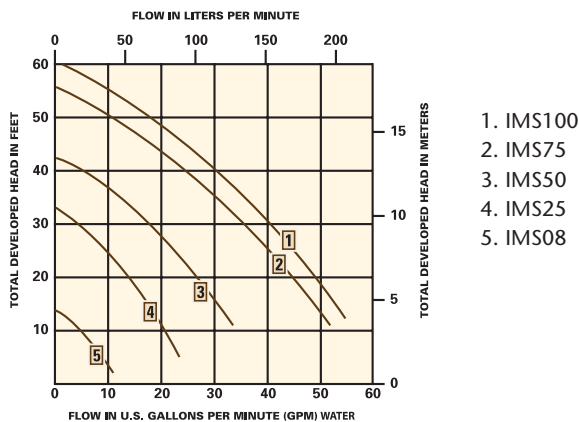

CROSS REFERENCE CHART FOR SUCTION-STYLE PUMPS

GRAYMILLS	GUSHER	AMT	TEEL/DAYTON	FUJI	OLD FUJI#	MITSUBISHI	TOSHIBA	HITACHI	YASUKAWA
IMS08	VBH-18	538A-95	4RC26	VKN-043A	VKN-041A	NP-60J	OPF-60M	CPS-041	VFPC-01F
IMS08		538B-95	4XZ18	VKN-053A	VKN-051A			CPS-063	VFPC-061JF
IMS25	VBH-14	539A-95	4RC27	VKN-063A	VKN-061A	NP-100J	OPF-100M	CPS-103	VFPC-101JF
IMS25	VHG-14	539B-95	4XZ19	VKN-073A	VKN-071A	NP-180J	OPF-180M	CPS-183	VFPC-181JF
IMS50	VBH-12	540A-95	4XZ20	VKN-083A	VKN-081A	NP-250J	OPF-250M	CPS-253	VFPC-251JF
IMS75	VBH-34	541A-95	4XZ21	VKN-093A	VKN-091A	NP-400J	OPF-400M	CPS-403	VFPC-401JF
IMS100	VBH-10	541B-95	4XZ22		VKN-112A				

Flange Mount Series



Flange Mount pumps are designed to mount to the outer wall of integral machine sumps or tanks. All Flange Mount pumps have two horizontal discharge ports as standard, with a single internal port available as an option. Sealed pumps are available for applications in which the pump motor is mounted below liquid level.

BSW/CSW SERIES SPECIFICATIONS

These pumps are identical in performance, differing only in flange and discharge size. Discharge diameter and maximum viscosity for each model are listed below. Pump performance and available motor suffixes are shown below. When ordering specify either BSW or CSW flange. Most pumps available as pump/tank combinations. See pages 25-29 or consult factory.

Sealed pumps are used when pump motor is mounted below liquid level.

BSW/CSW100H: 1/8 HP, 3450 RPM, 1/2" NPT horizontal discharge. Maximum viscosity: 500 SSU.

BSW/CSW200H: 1/4 HP, 3450 RPM, 1/2" NPT horizontal discharge. Maximum viscosity: 500 SSU.

BSW/CSW300H: 1/2 or 3/4 HP, 3450 RPM, 3/4" NPT horizontal discharge. Maximum viscosity: 500 SSU.

MATERIALS

Pump Body and Volute: Cast iron

Shaft: Carbon steel

Impeller: BSW/CSW100H: Celcon
 BSW/CSW200H: Aluminum
 BSW/CSW300H: Celcon
 DSW/ESW(ALL): Celcon

BSW/CSW ORDER INFORMATION—NON-SEALED PUMPS

B LENGTH	MODEL	HP	VOLTAGE SUFFIX
8"	BSW/CSW108H	1/8	A, B, F
10 1/2"	BSW/CSW111H	1/8	A, B, F
14 5/8"	BSW/CSW115H	1/8	A, B, F
8"	BSW/CSW208H**	1/4	A, B, F
10 1/2"	BSW/CSW211H**	1/4	A, B, F
14 5/8"	BSW/CSW215H**	1/4	A, B, F
8"	BSW/CSW308H	1/2, 3/4	E, F
10 1/2"	BSW/CSW311H	1/2, 3/4	E, F
12 1/4"	BSW/CSW313H	1/2, 3/4	E, F
14"	BSW/CSW314H	1/2, 3/4	E, F

BSWS/CSWS ORDER INFORMATION—SEALED PUMPS

B LENGTH	MODEL	HP	VOLTAGE SUFFIX
6"	BSWS/CSWS106H	1/8	A, B, F
6"	BSWS/CSWS206H**	1/4	A, B, F
6"	BSWS/CSWS306H	1/2, 3/4	E, F

**These models have cast aluminum impellers.

VOLTAGE SUFFIX CHART

Suffix	A	B	E	F	Z	GAM/GAMC
Voltage	115	230	115/230	230/460	575	Air motor
Hertz	50/60	50/60	50/60	50/60	60	
Phase	1	1	1	3	3	

BSW/CSW Series

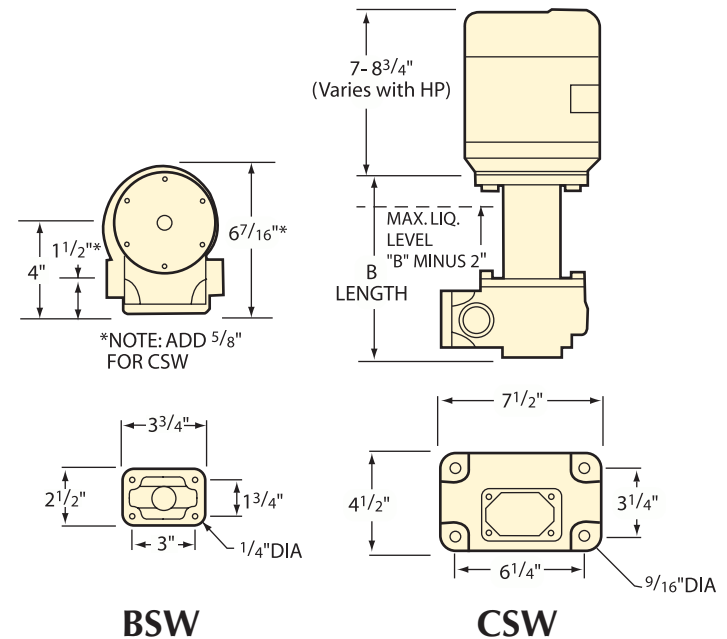

BSW/CSW SERIES PERFORMANCE

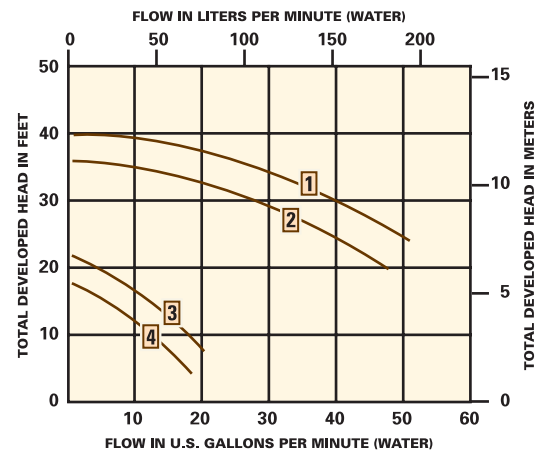

1. BSW/CSW300H-3/4
2. BSW/CSW300H-1/2
3. BSW/CSW200H-1/4
4. BSW/CSW100H-1/8

Flange Mount Series

DSW/ESW Series

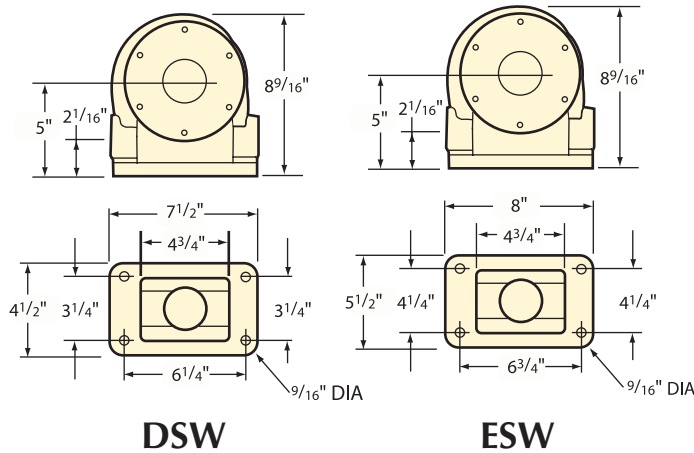
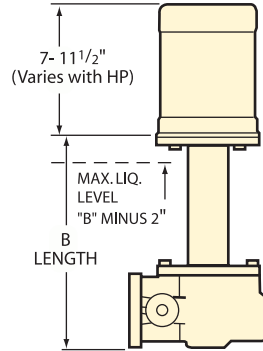

DSW

ESW

DSW/ESW SERIES PERFORMANCE

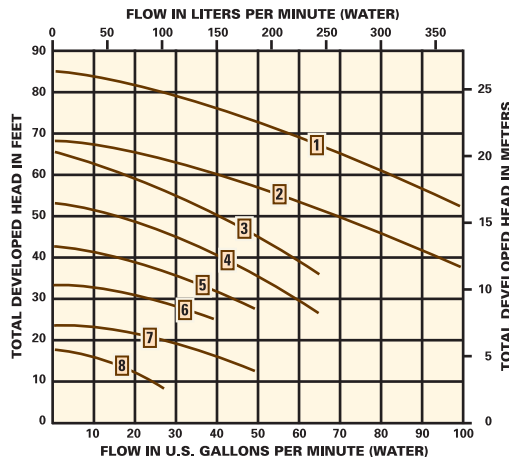

- | | |
|----------------------|--------------------|
| 1. DSW/ESW500H-3 | 5. DSW/ESW300H-3/4 |
| 2. DSW/ESW400H-2 | 6. DSW/ESW300H-1/2 |
| 3. DSW/ESW300H-1-1/2 | 7. DSW/ESW400-1/2 |
| 4. DSW/ESW300H-1 | 8. DSW/ESW300-1/4 |

DSW/ESW SERIES SPECIFICATIONS

These pumps are identical in performance, differing only in flange and discharge size. Discharge diameter and maximum viscosity for each model are listed below. Optional mounting accessories are available on page 34 for DSW/ESW pumps. Pump performance and available motor voltages are shown below.

DSW/ESW 300: 1/4 HP, 1725 RPM, 3/4" NPT horizontal discharge. Maximum viscosity: 500 SSU.

DSW/ESW 300H: 1/2, 3/4, 1, 1-1/2 HP, 3450 RPM, 1" NPT horizontal discharge. Maximum viscosities: 1/2, 3/4, 1 HP; 300 SSU. 1-1/2 HP; 500 SSU.

DSW/ESW 400: 1/2 HP, 1725 RPM, 1" NPT horizontal discharge. Maximum viscosity: 500 SSU.

DSW/ESW 400H: 2 HP, 3450 RPM. 1 1/2" horizontal discharge (DSW models supplied with 1 1/4" NPT reducer). Maximum viscosity: 300 SSU.

DSW/ESW 500H: 3 HP, 3450 RPM. 1 1/2" horizontal discharge (DSW models supplied with 1 1/4" NPT reducer). Maximum viscosity: 300 SSU.

DSW/ESW ORDER INFORMATION

B LENGTH	MODEL	HP	VOLTAGE SUFFIX
DSW—NON-SEALED PUMPS			
8 3/4"	DSW309	1/4	E, F
11 1/4"	DSW312	1/4	E, F
13 1/2"	DSW314	1/4	E, F
14 3/4"	DSW315	1/4	E, F
16 7/8"	DSW317	1/4	E, F
8 3/4"	DSW309H	1/2, 3/4, 1, 1-1/2	E, F
11 1/4"	DSW312H	1/2, 3/4, 1, 1-1/2	E, F
13 1/2"	DSW314H	1/2, 3/4, 1, 1-1/2	E, F
14 3/4"	DSW315H	1/2, 3/4, 1, 1-1/2	E, F
8 3/4"	DSW409	1/2	E, F
11 1/4"	DSW412	1/2	E, F
13 1/2"	DSW414	1/2	E, F
14 3/4"	DSW415	1/2	E, F
16 7/8"	DSW417	1/2	E, F
8 3/4"	DSW409H	2	F
11 1/4"	DSW412H	2	F
13 1/2"	DSW414H	2	F
14 3/4"	DSW415H	2	F
16 7/8"	DSW417H	2	F
8 3/4"	DSW509H	3	F
11 1/4"	DSW512H	3	F
13 1/2"	DSW514H	3	F
14 3/4"	DSW515H	3	F
16 7/8"	DSW517H	3	F

ESW—NON-SEALED PUMPS

9 1/4"	ESW310	1/4	E, F
11 3/4"	ESW312	1/4	E, F
14"	ESW314	1/4	E, F
15 1/4"	ESW316	1/4	E, F
17 3/8"	ESW318	1/4	E, F
9 1/4"	ESW310H	1/2, 3/4, 1, 1-1/2	E, F
11 3/4"	ESW312H	1/2, 3/4, 1, 1-1/2	E, F
14"	ESW314H	1/2, 3/4, 1, 1-1/2	E, F
9 1/4"	ESW410	1/2	E, F
11 3/4"	ESW412	1/2	E, F
14"	ESW414	1/2	E, F
15 1/4"	ESW416	1/2	E, F
17 3/8"	ESW418	1/2	E, F
9 1/4"	ESW410H	2	F
11 3/4"	ESW412H	2	F
14"	ESW414H	2	F
15 1/4"	ESW416H	2	F
17 3/8"	ESW418H	2	F
9 1/4"	ESW510H	3	F
11 3/4"	ESW512H	3	F
14"	ESW514H	3	F
15 1/4"	ESW516H	3	F
17 3/8"	ESW518H	3	F

DSWS/ESWS—SEALED PUMPS

8 3/4"	DSWS309	1/4	F
8 3/4"	DSWS409	1/2	F
8 3/4"	DSWS309H	1/2, 3/4, 1, 1-1/2	F
9 1/4"	ESWS310	1/4	F
9 1/4"	ESWS310H	1/2, 3/4, 1, 1-1/2	F
9 1/4"	ESWS410	1/2	F

See page 4 for voltage information.



MVP Multi-stage Series



MVP pumps, available in 4, 6, 8, 12, 16 and 20 stages, are designed to meet fluid delivery requirements where high pressure is needed to accomplish chip removal in addition to dissipating heat. The multi-stage construction offers the ability to cost-effectively match the pump to your application for pressures up to 326 psi and flows up to 28 gpm.

MVP SERIES SPECIFICATIONS

Stainless steel impellers, column and shaft provide robust construction for long service life. The ability to mount the pump both horizontally and vertically without loss of performance makes the MVP the most versatile high pressure pump on the marketplace.

The MVP's steady, pulsation-free fluid flow permits greatly increased feed rates while preventing thermal shock to cutting tools.

The cast iron frame and coupling provide a rugged interface between motor and shaft, resulting in a solid connection that eliminates vibration.

These versatile pumps can be used in applications where high pressure fluid delivery is required.

All Models: 1" NPT discharge, 230/460V

MVP4: 1HP, 3450 RPM, Maximum Discharge Pressure 65 PSI

MVP6: 2 HP, 3450 RPM, Maximum Discharge Pressure 95 PSI

MVP8: 2 HP, 3450 RPM, Maximum Discharge Pressure 120 PSI

MVP12: 3 HP 3450 RPM, Maximum Discharge Pressure 190 PSI

MVP16: 4 HP 3450 RPM, Maximum Discharge Pressure 250 PSI

MVP20: 5 HP 3450 RPM, Maximum Discharge Pressure 326 PSI

MATERIALS

Discharge Head and Frame: Cast iron

Shaft: Stainless Steel

Bowl: Stainless Steel

Column: Stainless Steel

Impeller/Diffuser: Stainless Steel

MVP Series

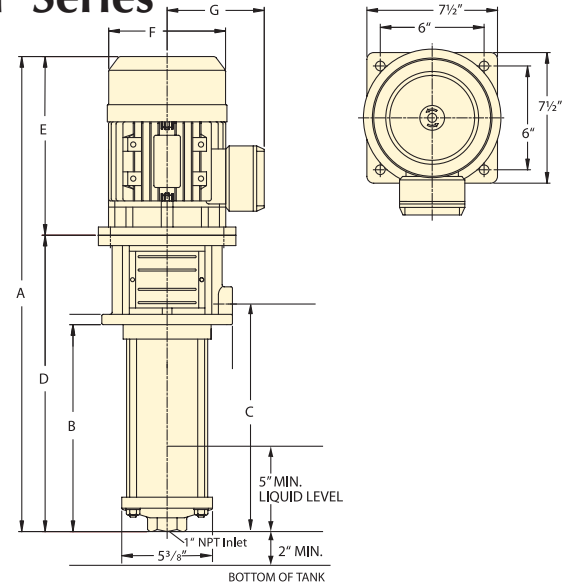

MODEL	HP	A	B	C	D	E	F	G
MVP4	1	21"	5 1/2"	6 3/4"	10 3/4"	10 1/2"	6 1/4"	5 3/8"
MVP6	2	23 1/2"	7 1/8"	8 1/4"	12 1/4"	11 1/4"	6 3/4"	5 3/4"
MVP8	2	25"	8 3/4"	9 7/8"	13 3/4"	11 1/4"	6 3/4"	5 3/4"
MVP12	3	29 1/4"	11 7/8"	13"	17"	12 1/4"	6 3/4"	5 3/4"
MVP16	4	33 3/4"	15"	16 1/8"	20"	13 1/2"	7 3/8"	6 3/8"
MVP20	5	37 1/4"	18 1/8"	19 1/4"	23 1/4"	14"	7 5/8"	6 3/8"

MVP SERIES PERFORMANCE

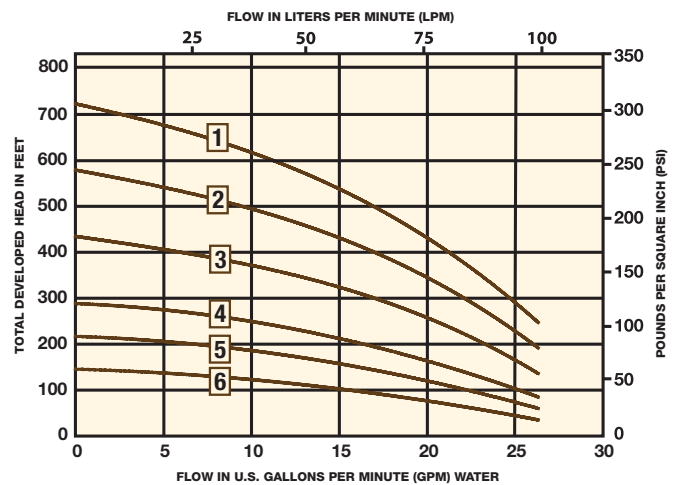

1. MVP20, 326 PSI Max Discharge
2. MVP16, 250 PSI Max Discharge
3. MVP12, 190 PSI Max Discharge
4. MVP8, 120 PSI Max Discharge
5. MVP6, 95 PSI Max Discharge
6. MVP4, 65 PSI Max Discharge



MSPR Multi-stage Series

MSPR Multi-stage, high pressure pumps, available in 5, 7, 9 or 13 stages, are designed to meet fluid delivery requirements where high pressure is needed to accomplish chip removal in addition to dissipating heat. The multi-stage construction offers the ability to cost-effectively match the pump to your application for pressures up to 180 psi and flows up to 38 gpm.



MSPR/MSPRSS Series

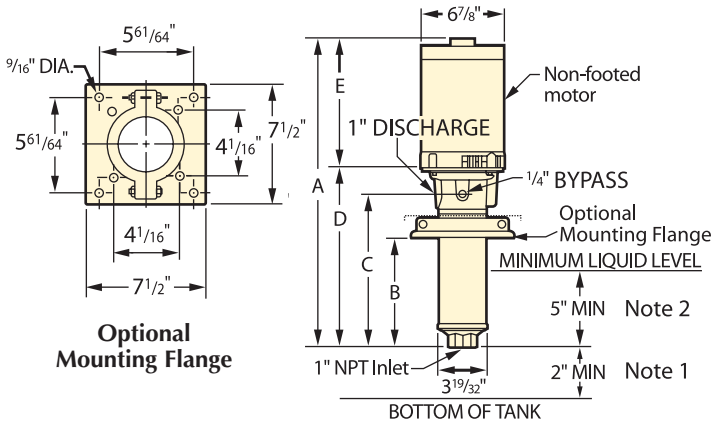

MSPR/MSPRSS ORDER INFORMATION

MODEL	STAGES	HP	A	B	C	D	E
MSPR/MSPRSS5	5	1	21 1/4"	6 1/4"	9 1/4"	11 1/4"	10"
MSPR/MSPRSS7	7	1 1/2	24"	8"	11 1/2"	13 1/4"	10 3/4"
MSPR/MSPRSS9	9	2	26"	9 5/8"	13"	15"	11"
MSPR/MSPRSS13	13	3	30 1/2"	13 1/2"	16 3/4"	18 3/4"	11 3/4"

Note 1: Graymills uses B length to define the measurement from the bottom of the volute to the bottom of mounting flange.

Note 2: Intake of pump must be a minimum of 2" above bottom of tank.

Note 3: Liquid level must always cover at least 5" of pump at all times.

MSPR/MSPRSS SERIES SPECIFICATIONS

Designed for long service life, pumps have rugged cast iron (MSPR) or stainless steel (MSPRSS) discharge head and frame while the corrosion resistant 300 series stainless steel and thermoplastic internal components are encased in a stainless steel shell. Mechanical seal has carbon/ceramic faces, Viton elastomers and stainless steel parts. May be mounted vertically or horizontally without loss of performance.

The MSPR Pump offers steady, pulsation-free coolant delivery while preventing thermal shock to cutting tools and greatly increasing feed rates. Perfect for "through the tool" machining applications and substantially lengthens tool life.

For variable capacity, centrifugal pump design allows flow adjustment by installing a valve in the pump discharge line (use of the included by-pass kit may be required). Integral discharge simplifies plumbing. No extra holes in tank lid.

Most pumps available as pump/tank combinations. See pages 25-29 or consult factory.

All Models: 1" NPT horizontal discharge, 230/460V.

MSPR5: 1 HP, 3450 RPM. Maximum Discharge Pressure 60 PSI. Maximum Viscosity 300 SSU.

MSPR7: 1-1/2 HP, 3450 RPM. Maximum Discharge Pressure 90 PSI. Maximum Viscosity 300 SSU.

MSPR9: 2 HP, 3450 RPM. Maximum Discharge Pressure 120 PSI. Maximum Viscosity 300 SSU.

MSPR13: 3 HP, 3450 RPM. Maximum Discharge Pressure 180 PSI. Maximum Viscosity 300 SSU.

MSPR/MSPRSS SERIES PERFORMANCE

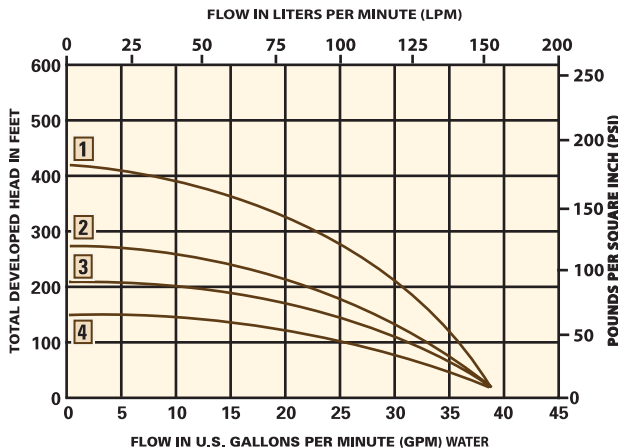

1. MSPR13, 180 PSI Max Discharge
2. MSPR9, 120 PSI Max Discharge
3. MSPR7, 90 PSI Max Discharge
4. MSPR5, 60 PSI Max Discharge

MATERIALS

Discharge Head and Frame:

- MSPR, Cast iron
- MSPRSS, Stainless steel

Shaft: Stainless steel

Bowl: Stainless steel

Column: Stainless steel

Impeller/Diffuser: Polycarbonate

Special Materials: Consult Factory for Pricing



Double Diaphragm Series



The Double Diaphragm Series is a high pressure, air-driven diaphragm pump, ideal for fluid transfer. They are corrosion-resistant, self-priming, self-cleaning, and portable. Surge suppressor is available when smooth flow is required.

DOUBLE DIAPHRAGM SERIES SPECIFICATIONS

Double diaphragm pumps operate by the movement of two flexible diaphragms which move back and forth, alternately filling and emptying two chambers. Diaphragms do have a pulsating flow and are best used with a Graymills surge suppressor/filter. Flow is controlled with the air inlet valve, which then determines pump speed. Graymills pumps are self-priming with a dry lift capability ranging from 10' to 18' and a maximum flow rate of 40 GPM. Operates on standard air service.

- The unique "slide-valve" design in 1/4", 1/2" and 1" models prevents stalling even when running at the lowest speeds
- Pumps are designed for easy maintenance with a minimum number of parts. The air valve assembly is externally serviceable (no need to dismantle pump)
- For applications requiring controlled flow rates from a trickle up to 40 gallons per minute
- No air line lubrication is necessary (1/4", 1/2", 1" only)
- Self-priming with the ability to pump liquids containing small solids

MATERIALS

1/4", 1/2", 1" Models

- Pump Body:** 1/4", 1/2", Polypropylene
1", Polypropylene or Aluminum
- Diaphragms:** 1/4", Teflon®
1/2" & 1", Teflon® or Hytrel.
- Ball Check Valves:** 1/4" Polypropylene
1/2" & 1", Teflon® or Hytrel.

3/4" Model

- Pump Body:** Teflon® Coated Aluminum.
- Diaphragms:** Gylon® (enhanced PTFE)
- Ball Check Valves:** Delrin or Stainless Steel.*

*3/4" Models with standard Delrin ball checks handle viscosities up to 1100 CPS; with optional stainless steel ball checks, 2250 CPS.

AIR-OPERATED DOUBLE DIAPHRAGM TRANSFER PUMP MODEL DPTG-50-DRUM

- Features 1-in/1-out 1/2" pump with Teflon® diaphragms and bottom suction manifold
- Quick priming and immediate flow. Runs dry without damage
- Handles fluid viscosities up to 5,000 CPS and solids up to 0.09 inches
- Pump slides in and out of drums through bung adapter without the need to disconnect hoses
- Pump is never immersed inside the drum

Double Diaphragm Series

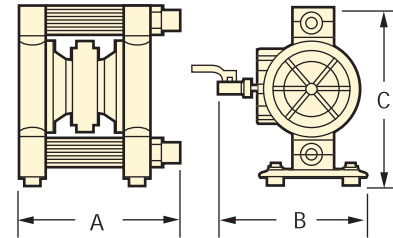

1/4", 1/2", 1" Models

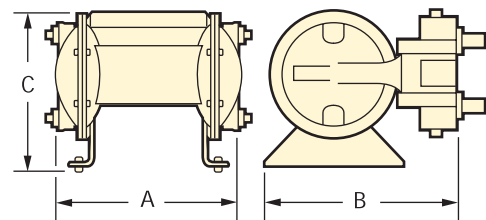

3/4" Models

MODEL	A	B	C
1/4"	6 ⁷ / ₃₂ "	6 ¹ / ₂ "	5 ¹³ / ₁₆ "
1/2"	8 ⁷ / ₈ "	9 ⁵ / ₃₂ "	11 ³ / ₄ "
3/4"	10"	10 ¹ / ₄ "	9"
1"	13 ⁷ / ₃₂ "	13 ³ / ₈ "	17"

DOUBLE DIAPHRAGM PUMP SPECIFICATIONS

MODEL	1/4"	1/2"	3/4"	1"
Dry Lift Capability	10 ft.	15 ft.	18 ft.	18 ft.
Total Developed Head	150 ft.	150 ft.	231 ft.	150 ft.
Air Consumption@70 PSI	7 CFM	18 CFM	10 CFM	30 CFM
Maximum Flow	5 GPM	15 GPM	12 GPM	40 GPM
Air Inlet (NPT-F)	1/4"	1/4"	1/8"	1/2"
Maximum Inlet Pressure	100 PSI	100 PSI	100 PSI	100 PSI
Maximum Viscosity (Centipoise)	500	5,000	2,250*	10,000
Inlet/Outlet Options				
1 Inlet/1 Outlet	X	X	X	X
1 Inlet/2 Outlets			X	

*3/4" Models with standard Delrin ball checks handle viscosities up to 1100 CPS; with optional stainless steel ball checks, 2250 CPS.

Double Diaphragm Series



1" Polypropylene
(also available in aluminum)

1/2" Polypropylene



1/4" Polypropylene



3/4" Aluminum

DOUBLE DIAPHRAGM PUMP ORDER INFORMATION

PUMP	DIAPHRAGMS	BALL CHECKS	INLET / OUTLET CONFIGURATION
1/4" Models			
DPTG-25	Teflon®	Polypropylene	1 in / 1 out
1/2" Models			
DPHG-50	Hytrel	Hytrel	1 in / 1 out
DPTG-50	Teflon®	Teflon®	1 in / 1 out
DPTG-50-DRUM	Teflon®	Teflon®	1 in / 1 out
3/4" Models			
DDPB-11TC	Gylon®	Delrin	1 in / 1 out
DDPB-12TC	Gylon®	Delrin	1 in / 2 out
DDPB-11TSSC	Gylon®	Stainless Steel	1 in / 1 out
DDPB-12TSSC	Gylon®	Stainless Steel	1 in / 2 out
1" Models - Aluminum			
DAHG-100	Hytrel	Hytrel	1 in / 1 out
DATG-100	Teflon®	Teflon®	1 in / 1 out
1" Models - Polypropylene with ANSI Flange			
DPTG-100	Teflon®	Teflon®	1 in / 1 out
DPHG-100	Hytrel	Hytrel	1 in / 1 out

Other configurations available. Consult factory.

Valve Kit Story



3/4" DDP Repair Kit varies.

Theirs



Quick-Change Air Valve Service Kits Have Over 50% Fewer Parts than Competitors... and the Pump is Externally Serviceable

Graymills diaphragm pumps feature air valve service kits that are 100% externally serviceable and contain a maximum of 10 parts. Competitor service kits have 20 to 30 parts that need to be replaced and their pumps must be completely disassembled to service the air valve. Look at these remarkable differences:

- Extremely reliable—resists stalling.
- Fewer parts—repair kits have up to 50% fewer parts than traditional valve kits.
- Ease of repair—the air valve can be repaired externally. The pump itself never has to be disassembled. Repairs are so easy they can take place where the pump is installed, which saves time, money and frustration.
- Unique U-cup seals—last longer and are more reliable than o-ring seals.
- Less prone to icing—no small passages where ice can build.
- No lubrication required—pump performance will not be adversely affected by "dirty" or unconditioned air.

SG Gear Series

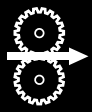

The SG Series are gear pumps specially designed for high pressure applications. These pumps are recommended for use with liquids that have some lubricating qualities and are relatively free of abrasives and scale. **NOTE: NOT TO BE USED TO PUMP NON-LUBRICATING LIQUIDS, SUCH AS WATER.**

SG SERIES SPECIFICATIONS

SG Series gear pumps provide pressure up to 70 PSI and 3 GPM for applications where consistently high pressure is needed for small tubing, oil hole drills, high velocity jets through nozzles and for heavy viscosity oils. Cutting oils, coolants, lubricants, drawing compounds and some solvents are the types of fluids typically pumped with SG Series pumps. These pumps and systems are recommended for use with liquids that have some lubricating quality and are relatively free from abrasives and scale. SG Series gear pumps are often preferred for small lathes and drills.

SG Series pumps mount vertically in tanks and containers. They are self-priming and the intake can be located several feet below the pump. All units are supplied with relief valve and intake filter. Most pumps available as pump/tank combinations. See pages 25-29 or consult factory.

SG1: 1/25 HP, 1500 RPM. Maximum pressure: 22 PSI, 3/8" NPT vertical discharge. Maximum viscosity: 2000 SSU.

SG2: 1/8 HP, 1725 RPM. Maximum pressure: 40 PSI, 3/8" NPT vertical discharge. Maximum viscosity: 5000 SSU.

SG4: 1/4, 1/2 HP, 1725 RPM. Maximum pressure: 1/4 HP- 50 PSI, 1/2 HP- 70 PSI, 3/8" NPT vertical discharge. Maximum viscosity for both: 5000 SSU.

MATERIALS

Pump Body: Cast iron

Gears: Hardened steel

Bearings: Bronze with Oilite

SG Series

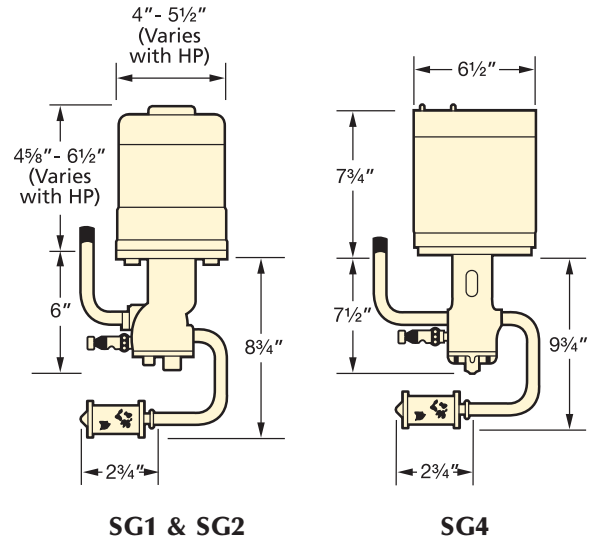

SG ORDER INFORMATION

MODEL	HP	RPM SUFFIX	VOLTAGE	PERFORMANCE
SG1	1/25	1500	A, B	1 GPM at 10 PSI Maximum 22 PSI
SG2	1/8	1725	A, B, F	1.2 GPM at 10 PSI Maximum 40 PSI
SG4	1/4	1725	E, F	3 GPM at 10 PSI Maximum 50 PSI
SG4	1/2	1725	E, F	3 GPM at 10 PSI Maximum 70 PSI

VOLTAGE SUFFIX CHART

Suffix	A	B	E	F	Z	GAM/GAMC
Voltage	115	230	115/230	230/460	575	Air motor
Hertz	50/60	50/60	50/60	50/60	60	
Phase	1	1	1	3	3	

Specialty Pumps and Tanks

These pumping systems offer special design features or operating characteristics that allow them to be used in applications where more traditional systems don't fit or work well. Details like built-in sumps, internal agitation to keep solids in suspension, compact footprint or low profiles provide the flexibility required to fit those special applications.



5 Gallon Round

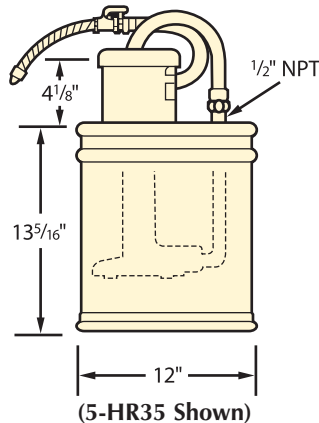

MODEL	PUMP MODEL	HP	VOLTAGE SUFFIX
5 GALLONS			
5-HR35	HR35	1/25	A, B
5-SG1	SG1	1/25	A, B

5 GALLON ROUND TANK SYSTEM

The 5-HR35 tank system can be used for light oils and other liquids to 150 SSU.

5-HR35: 1/25 HP, 1500 RPM, 1/2" NPT discharge centrifugal pump with 6' cord, plug and switch, 4' neoprene 1/2" ID hose, 1/4" ID flexible metal nozzle and valve, mesh screen filter bowl. May be ordered without hose and nozzle.

5-SG1: 1/25 HP, 1500 RPM, 3/8" NPT discharge gear pump with 6' cord, plug and switch, 4' neoprene 3/8" ID hose, flexible metal nozzle and valve, mesh screen filter bowl. May be ordered without hose and nozzle.

The 5-SG1 system is recommended for applications requiring consistently high pressure for liquids that have some lubricating value and are relatively free of abrasives and scale. Maximum viscosity: 2,000 SSU.

AGITATOR ROUND TANK SYSTEMS

These systems are designed for a wide variety of liquids that require constant circulation to maintain uniform viscosity or contain solids which must be kept in suspension. This is accomplished by use of a by-pass in the volute that diverts some of the flow from the discharge in the pump base. All pump bodies used in these systems feature Teflon®-coated cast iron construction with open column, tri-rod design for easy pump clean-up. Polyethylene tank liners are available for easier clean-up and additional resistance to corrosion and abrasion. See page 35 for details. All motors 1725 RPM. For additional information on pumps see Agitator Series on page 9.

2-HRTG: 2 gallon stainless steel tank and lid, 1/8 HP, 1/2" NPT discharge. Maximum viscosity: 500 SSU. Delivers 2 GPM at 10' head.

10-TNRT: 10 gallon mild steel tank with nickel plated lid, 1/4 or 1/2 HP, 3/4" NPT discharge. Maximum viscosity: 500 SSU.

20-TNRT: 20 gallon mild steel tank with nickel plated lid, 1/4 or 1/2 HP, 1" NPT discharge. Maximum viscosity: 500 SSU.

30-TNRT: 30 gallon mild steel tank with nickel plated lid, 1/4 or 1/2 HP, 1" NPT discharge. Maximum viscosity: 500 SSU.

Agitator Round Tank Systems

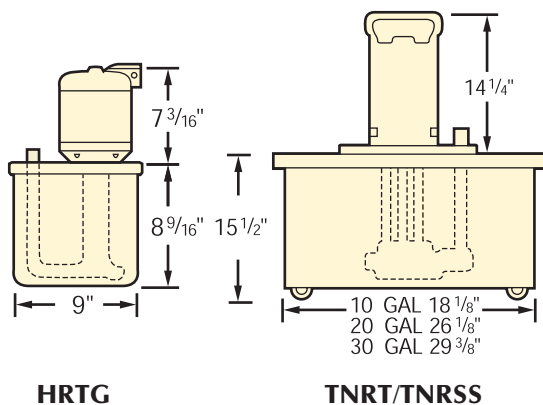

MODEL	PUMP MODEL	HP	VOLTAGE SUFFIX
AGITATOR ROUND TANK SYSTEMS			
2-HRTG	HRTG	1/8	E, F, GAM
10-TNRT	TNRT36	1/4, 1/2	E, F, GAMC
20-TNRT	TNRT36	1/4, 1/2	E, F, GAMC
30-TNRT	TNRT36	1/4, 1/2	E, F, GAMC

MODEL	PUMP MODEL	HP	VOLTAGE SUFFIX
STAINLESS STEEL AGITATOR SYSTEMS			
10-TNRSS	TNRSS36	1/4, 1/2	E, F, GAMC
20-TNRSS	TNRSS36	1/4, 1/2	E, F, GAMC
30-TNRSS	TNRSS36	1/4, 1/2	E, F, GAMC

AGITATOR TNRSS STAINLESS STEEL SYSTEMS

All three systems feature upgraded, all stainless steel pumps with 1" NPT discharge and round stainless steel tanks and lids. Maximum viscosity: 500 SSU. Available in 10, 20 and 30 gallon sizes.

Pump and Tank Systems

At Graymills, we recognize the need to combine the rugged dependability of our pumps with a variety of tank sizes and shapes, to provide a comprehensive line of fluid collection and recirculating systems. We know that these tank systems will see a lot of hard work and rough treatment during their long working lives. That's why Graymills designs its tanks the way they should be built . . . like a tank. To prove our point, take a look at the cutaway below and notice the built-in durability and quality.

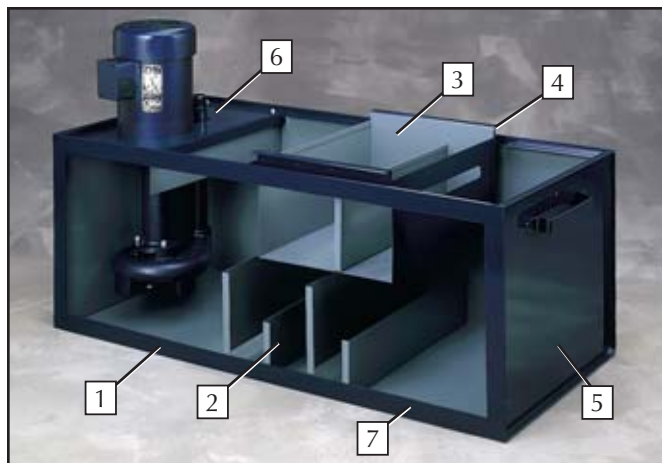

Features, capabilities and materials differ from tank to tank, but each follows in the Graymills tradition of quality and dependability. We don't believe in short-cuts that might compromise the quality of our products . . . or your satisfaction. And if you need a special, one-of-a-kind pumping system, we are ready to design and build one to meet your specific requirements. For more information on any of our products or help in ordering, call us or a member of our nationwide network of distributors. We're ready to solve your pumping and fluid circulating problems.

A wide selection of standard pump and tank systems are available to meet your requirements.

1. Durably constructed of cold rolled steel with a powder coated finish. Stainless tanks also available.
2. Tank systems larger than 5 gallons contain from one to four baffles, carefully sized and positioned to make solids settle out and keep circulated fluid clean.
3. Depending on tank size and flow requirements, tanks larger than 5 gallons are equipped with either a wire mesh screen bowl or chip collection basket. On the coolant return, chip collection baskets have an extra baffle and a fluid return slot to further aid the settling process.
4. Tank and collection basket edges are hemmed to eliminate exposed sharp edges and increase rigidity.
5. For improved adhesion all exterior tank surfaces are cleaned with a phosphatized wash prior to powder coating.
6. Lids are recessed to contain spills.
7. To assure maximum strength and uniformity, tanks are jig and fixture assembled and spot welded prior to MIG seam welding. Every tank is then dye penetrant-tested for 24 hours. Not even a pinhole leak can slip past this procedure. As a result of these stringent procedures, each tank carries Graymills' one year warranty.

We also manufacture custom systems for unique applications and OEMs.

Standard Systems Selection

Tank Size	Tank Features	Pumps Available in Standard Units (Reference page numbers for complete pump data)
3 Gallon	Screen filter bowl	VPJ25 (page 14)
5 Gallon	Screen filter bowl	HR35 (page 10)
6 Gallon	Screen filter bowl; 1 baffle in tank	HR35 (page 10), FM68H (page 11)
10 Gallon	Screen filter bowl or chip basket; 1 baffle in tank	TN33 (page 6), HR35, HR45 (page 10), FM68H (page 11)
17 Gallon	Screen filter bowl or chip basket; 2 baffles in tank	TN33, TN333H (page 6), FM68H (page 11)
21 Gallon	Chip basket and 1 baffle in tank	TN31 (page 6), TN41 (page 7)
34 Gallon	Chip basket and 3 baffles in tank	TN37H-1, TN37H-1½ (page 6), TNW46H, TN56 (page 7), TNW67, TNW77 (page 8)
50 Gallon	Chip basket and 4 baffles in tank	TN37H-1, TN37H-1½ (page 6), TN46, TN56, TN57H-3 (page 7), TN67, TN77 (page 8)
85 Gallon	Chip basket and 3 baffles in tank	TN37H-1½ (page 6), TN57, TN57H-3 (page 7), TN77 (page 8)
110 Gallon	Chip basket and 3 baffles in tank	TN57, TN57H-3 (page 7), TN77 (page 8)

Pump/Tank systems available for High Pressure MSPR and MVP pumps. Consult Factory.

3-6-10-17 GALLON SYSTEMS

All units are constructed with 18 gauge steel and contain a screen filter bowl.

3 GALLON TANK SYSTEM

3-VPJ25: Features a Graymills VPJ25 abrasive resistant pump made of high strength thermoplastic. Pump: 1/25 HP, 1500 RPM, 5/8" ID discharge. Maximum viscosity: 300 SSU. Tank is 18 gauge steel. Four feet of 1/2" vinyl hose. Screen filter bowl.

6 GALLON TANK SYSTEMS

6-HR35: 1/25 HP, 1500 RPM. Maximum viscosity: 150 SSU. Optional 3/8" ID flexible metal nozzle with valve and 4' neoprene 1/2" ID hose. 1/2" NPT discharge.

6-HR45: 1/8 HP, 1725 RPM. Maximum viscosity: 500 SSU. Optional 3/8" ID flexible metal nozzle with valve and 4' neoprene 1/2" ID hose. 1/2" NPT discharge.

Pump and Tank Systems

3-6-10-17 GALLON TANK SYSTEMS

Pump and Tank systems with 3-17 gallon capacities are furnished with either a mesh screen bowl or chip collection basket. Consult model listings below for availability of these options.



6-FM68H: 1/8 HP, 3450 RPM. Maximum viscosity: 500 SSU. 1/2" NPT discharge.

6-SG2: 1/8 HP, 1725 RPM. Maximum viscosity: 5,000 SSU. Includes intake filter, relief valve and 3/8" discharge pipe. Hoses, fittings and special filters available as accessories. Recommended for use with Graymills Stocklube® Systems.

10 GALLON TANK SYSTEMS

Tanks are constructed from 18 gauge steel with a single built-in baffle. Either a chip basket or a screen filter bowl can be ordered, depending on the model. All "X" prefix models have chip baskets instead of screen filter bowls.

10-IMV: 1/8 HP, 3450 RPM, 1/2" NPT discharge through integral flange. Maximum viscosity: 500 SSU. 10-IMV does not come with baffle.

11-HR35: 1/25 HP, 1500 RPM. 1/2" NPT discharge. Maximum viscosity: 150 SSU. Optional 3/8" ID flexible metal nozzle and valve, 4' neoprene 1/2" ID hose.

11-HR45: 1/8 HP, 1725 RPM, 1/2" NPT discharge. Maximum viscosity: 500 SSU. Optional 3/8" ID flexible metal nozzle with valve, 4' neoprene 1/2" ID hose.

11-FM68H: 1/8 HP, 3450 RPM, 1/2" NPT discharge through integral flange. Maximum viscosity: 500 SSU.

X11-TN33: 1/4 HP, 1725 RPM. 3/4" NPT discharge. Maximum viscosity: 500 SSU. Chip basket standard.

11-SG1: 1/25 HP, 1500 RPM, gear pump. Maximum viscosity: 2,000 SSU. Optional 1/4" flexible metal nozzle with valve, 4' neoprene 3/8" ID hose. 6' cord, plug, and switch.

11-SG2: 1/8 HP, 1725 RPM, gear pump. Maximum viscosity: 5,000 SSU. Includes 1/4" flexible metal nozzle with valve, 4' neoprene 3/8" ID hose.

11-SG4: 1/4 HP or 1/2 HP, 1725 RPM, gear pump. Maximum viscosity: 5,000 SSU. Includes 1/4" flexible metal nozzle with valve, 4' neoprene 3/8" ID hose. Recommended for use with Graymills Stocklube® Systems.

17 GALLON TANK SYSTEMS

Tanks are constructed of 16 gauge steel with two built-in baffles and either a chip basket or screen filter bowl.

17-FM68H: 1/8 HP, 3450 RPM, 1/2" NPT discharge through integral flange. Maximum viscosity: 500 SSU. 18 mesh screen bowl. Available with optional chip basket.

X17-TN33: 1/4 HP, 1725 RPM, 3/4" NPT discharge. Maximum viscosity: 500 SSU. Chip basket standard.

X17-TN33H: 3/4 HP, 3450 RPM, 1" NPT discharge. Maximum viscosity: 300 SSU. Chip basket standard.

3-6-10-17 Gallon

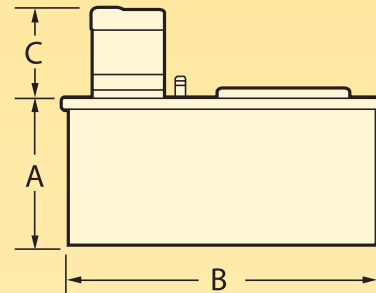

TANK SIZE (GAL.)	A	B	C*(Max.)	WIDTH
3	6 1/4"	16"	4 3/8"	9"
6	9"	18"	7 3/8"	9 1/2"
10-IMV	10 1/2"	24"	5 1/2"	9 3/4"
10	11 3/8"	25"	8 1/2"	10"
17	11 1/2"	28"	11 1/2"	14"

* Motor height changes with HP, maximum.

ORDER INFORMATION

MODEL	PUMP MODEL	HP	VOLTAGE SUFFIX
3 GALLONS			
3-VJ5	VPJ25	1/25	A, B
6 GALLONS			
6-HR35	HR35	1/25	A, B
6-HR45	HR45	1/8	A, B, E, F
6-FM68H	FM68H	1/8	E, F
6-SG2	SG2	1/8	A, B, F
10 GALLONS			
10-IMV	IMV08	1/8	E, F
11-HR35	HR35	1/25	A, B
11-HR45	HR45	1/8	A, B, E, F
11-FM68H	FM68H	1/8	A, B, F
X11-TN33	TN33	1/4	E, F
11-SG1	SG1	1/25	A, B
11-SG2	SG2	1/8	A, B, F
11-SG4	SG4	1/4	E, F
11-SG4	SG4	1/2	E, F
17 GALLONS			
17-FM68H	FM68H	1/8	E, F
X17-TN33	TN33	1/4	E, F
HIGH HEAD MODELS			
X17-TN33H	TN33H	3/4	F

"X" prefix in part number indicates chip basket is standard. Air motors available for certain models. Consult factory.

Pump and Tank Systems

21-34-50 GALLON TANK SYSTEMS

These mid-range pumping systems offer larger pumps and greater volume along with our chip basket feature to handle higher flow rates. Their size versus performance ratio makes them easily adaptable to a variety of applications as an upgrade to a standard pumping system, a capable addition to an existing machine tool or a central system for a multiple machine set-up.



21-34-50 GALLON SYSTEMS

21 GALLON TANK SYSTEMS

This unit's low height, 9^{3/4}", makes it ideal for applications with a low fluid return or for replacing old close-couple pumps. Tank is 16 gauge steel with one baffle. Chip basket standard. Maximum viscosity for either pump is 500 SSU.

X21-TN31: 1/4 HP, 1725 RPM, 3/4" NPT discharge.

X21-TN41: 1/2 HP, 1725 RPM, 1" NPT discharge.

X21-MSPR5: 1 HP, 3450 RPM. Maximum viscosity: 300 SSU. 1" NPT discharge.

34 GALLON TANK SYSTEMS

These models offer a wide variety of pumps to handle high head/volume requirements. Tank is 16 gauge steel, with three baffles built-in. Chip basket standard, except for 38-SG2.

X38-TN37: 1/4 HP, 1725 RPM, 3/4" NPT discharge.

Maximum viscosity: 500 SSU.

X38-TN46: 1/2 HP, 1725 RPM, 1" NPT discharge.

Maximum viscosity: 500 SSU.

X38-TN56: 3/4 HP, 1725 RPM, 1^{1/4}" NPT discharge.

Maximum viscosity: 500 SSU.

38-SG2: 1/8 HP, 1,725 RPM, gear pump. Maximum viscosity: 5,000 SSU. Screen filter bowl, 1/4" flexible metal nozzle with valve and 4' neoprene 3/8" ID hose.

X38-TN37H-1: 1 HP, 3450 RPM, 1" NPT discharge.

Maximum viscosity: 500 SSU.

X38-TN37H-1-1/2: 1-1/2 HP, 3450 RPM, 1" NPT discharge.

Maximum viscosity: 500 SSU.

X38-MSPR7: 1-1/2 HP, 3450 RPM. Maximum viscosity:

300 SSU. 1" NPT discharge.

50 GALLON TANK SYSTEMS

These systems provide the extra settling capabilities necessary for high flow applications. Tank is made of 16 gauge steel, with four baffles built-in. Chip basket standard.

X55-TN56: 3/4 HP, 1725 RPM, 1^{1/4}" NPT discharge.

Maximum viscosity: 500 SSU.

X55-TNW67: 1 HP, 1725 RPM, 1^{1/2}" NPT discharge.

Maximum viscosity: 500 SSU.

X55-TNW77: 1-1/2 HP, 1725 RPM, 2" NPT discharge.

Maximum viscosity: 500 SSU.

X55-TN37H-1: 1 HP, 3450 RPM, 1" NPT discharge.

Maximum viscosity: 500 SSU.

X55-TN37H-1-1/2: 1-1/2 HP, 3450 RPM, 1" NPT discharge.

Maximum viscosity: 500 SSU.

X55-TNW46H: 2 HP, 3450 RPM, 1^{1/4}" NPT discharge.

Maximum viscosity: 500 SSU.

X50-MSPR9: 2 HP, 3450 RPM. Maximum viscosity:

500 SSU. 1" NPT discharge.

21-34-50 Gallon

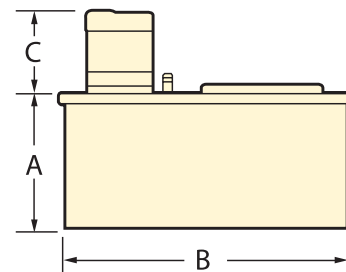

OVERALL DIMENSIONS

TANK SIZE (GAL.)	A	B	C *	(MAX.) WIDTH
21	9 ^{3/4} "	36"	10"*	16"
34	16 ^{1/2} "	37 ^{1/2} "	11 ^{1/2} **	16"
50	16 ^{1/2} "	42"	15"*	20"

* Motor height changes with HP, maximum.

ORDER INFORMATION

MODEL	PUMP MODEL	HP	VOLTAGE SUFFIX
21 GALLONS			
X21-TN31	TN31	1/4	E, F,
X21-TN41	TN41	1/2	E, F,
HIGH HEAD MODELS			
X21-MSPR5	MSPR5	1	F

34 GALLONS

X38-TN37	TN37	1/4	E, F
X38-TN46	TN46	1/2	E, F
X38-TN56	TN56	3/4	E, F
38-SG2	SG2	1/8	A, B, F
HIGH HEAD MODELS			
X38-TN37H-1	TN37H	1	F
X38-TN37H-1-1/2	TN37H	1-1/2	F
X38-MSPR7	MSPR7	1-1/2	F

50 GALLONS

X55-TN56	TN56	3/4	E, F
X55-TNW67	TNW67	1	E, F
X55-TNW77	TNW77	1-1/2	E, F
HIGH HEAD MODELS			
X55-TN37H	TN37H-1	1	F
X55-TN37H	TN37H-1-1/2	1-1/2	F
X55-TNW46H	TNW46H	2	F
X50-MSPR9	MSPR9	2	F

"X" prefix in part number indicates chip basket is standard.

Air motors available for certain models. Consult factory.

Pump/Tank systems available for High Pressure MSPR and MVP pumps. Consult Factory.

Pump and Tank Systems

85 AND 110 GALLON TANK SYSTEMS

Capable of handling very large or multiple machine installations along with many other applications where extra capacity is needed. Our largest standard systems offer the volumes and flow rates to meet the most demanding applications.



85 and 110 Gallon

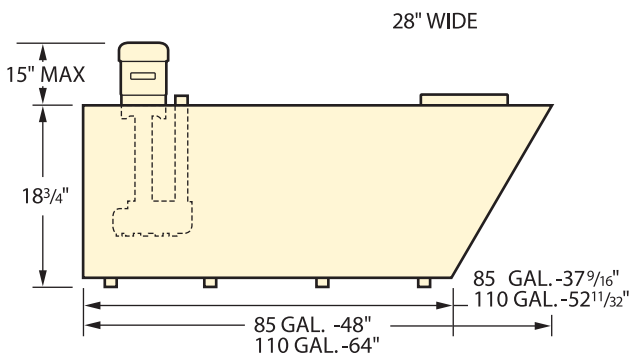

MODEL	PUMP MODEL	HP	VOLTAGE SUFFIX
85 GALLONS			
X85-TN57	TN57	3/4	E, F
X85-TNW77	TNW77	1-1/2	F
HIGH HEAD MODELS			
X85-TN37H-1-1/2	TN37H	1-1/2	F
X85-TNW57H	TNW57H	3	F
110 GALLONS			
X110-TN57	TN57	3/4	F
X110-TNW77	TNW77	1-1/2	F
HIGH HEAD MODELS			
X110-TNW57H	TNW57H	3	F

85 and 110 GALLON SYSTEMS

These two systems deliver the highest head and the greatest volume of the standard tank systems. Tanks are made of 12 gauge steel with three baffles in the tank and another in the chip basket. Channels support the tank off floor. A sloping end is featured for easy chip removal. Larger sizes available.

85 GALLON TANK SYSTEMS

X85-TN57: 3/4 HP, 1725 RPM, 1¹/₄" NPT discharge.

Maximum viscosity: 500 SSU.

X85-TNW77: 1-1/2 HP, 1725 RPM, 2" NPT discharge.

Maximum viscosity: 500 SSU.

X85-TN37H-1-1/2: 1-1/2 HP, 3450 RPM, 1" NPT discharge.

Maximum viscosity: 500 SSU.

X85-TNW57H: 3 HP, 3450 RPM, 1¹/₂" NPT discharge.

Maximum viscosity: 500 SSU.

110 GALLON TANK SYSTEMS

X110-TN57: 3/4 HP, 1725 RPM, 1¹/₄" NPT discharge.

Maximum viscosity: 500 SSU.

X110-TNW77: 1-1/2 HP, 1725 RPM, 2" NPT discharge.

Maximum viscosity: 500 SSU.

X110-TNW57H: 3 HP, 3450 RPM, 1¹/₂" NPT discharge.

Maximum viscosity: 500 SSU.

Low Profile Tank Systems

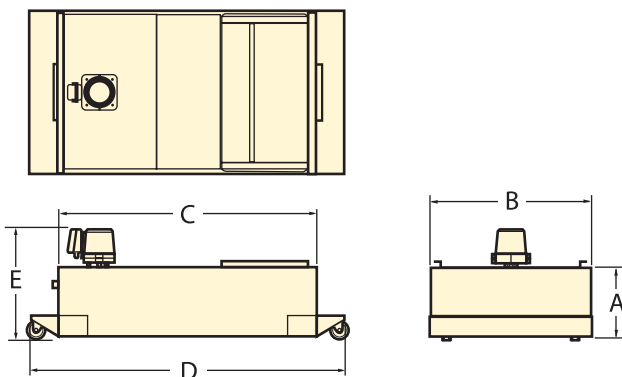

LOW PROFILE TANK DIMENSIONS

MODEL	Capacity	PUMP	A	B	C	D	E
X21-IMV08	21	IMV08	9 ³ / ₄ "	16"	36"	44"	15 ¹ / ₂ "
X30-IMV25	30	IMV25	9 ³ / ₄ "	20"	40"	48"	17 ³ / ₈ "
X50-IMV50	50	IMV50	12"	24"	45"	53"	20 ³ / ₈ "

These units combine the same durable features of our standard units with lower working heights, portability, and our economical IM Series pumps. They deliver outstanding value while

providing years of service. All units feature 16 gauge construction, chip baskets, internal baffles and swivel casters.



X21-IMV08: 1/8 HP, 3450 RPM, 3/8" NPT Discharge, Maximum Viscosity: 500 SSU.

X30-IMV25: 1/4 HP, 3450 RPM, 1/2" NPT Discharge, Maximum Viscosity: 500 SSU.

X50-IMV50: 1/2 HP, 3450 RPM, 3/4" NPT Discharge, Maximum Viscosity: 500 SSU.

Stocklube® Systems

Graymills Stocklube Systems provide neat, controlled lubrication of coil or strip stock. They save time, save lubricant, extend die life and prevent slippery floor hazards. Stocklube systems eliminate inefficient hand-brushing and messy containers. Ruggedly constructed to complement press speeds up to 300 FPM.

STOCKLUBE SYSTEM FEATURES

The systems consist of a lubricating head assembly and a pump and tank unit. Lubricating heads are available in three sizes for maximum sheet width of 6", 12" and 24" and are adjustable for stock thickness up to $\frac{3}{16}$ ".

Clean, uniform lubrication reduces die wear

The stock is coated with lubricant as it passes through application rollers operating under spring tension. Excess lubricant is squeezed off by the wiper rollers and drains to the pump reservoir where it is filtered and recirculated to the head. Stocklube heads are easily adjusted to lubricate stock up to $\frac{3}{16}$ ", either top, bottom or both sides simultaneously.

Uniform lubricant flow is easily adjusted with convenient manifold needle valves. In addition, the wiper rollers tend to clean dirt from the stock surface to keep foreign material from damaging dies. Dual manifold needle valves provide finger tip adjustment of the lubricant flowing on to the stock. This control allows operation at various production speeds.

Choice of steel or urethane rollers

Smooth steel rollers are standard with Graymills Stocklube Systems. Optional urethane-covered rollers are available for uniform lubricant distribution on stock with slightly irregular surfaces or burred edges.

Choice of centrifugal or gear pump systems

Centrifugal pump systems are for use with light oils and water-soluble mixtures up to 500 SSU. They will handle fluids containing abrasives or scale. For complete information, see FM60 Series centrifugal pumps, page 11.

Gear pump systems are for use with heavier lubricants (up to 5000 SSU) which are free of abrasives or scale. For complete pump information, see SG2 and SG4 Series gear pumps on page 24.

R6, R12, R24

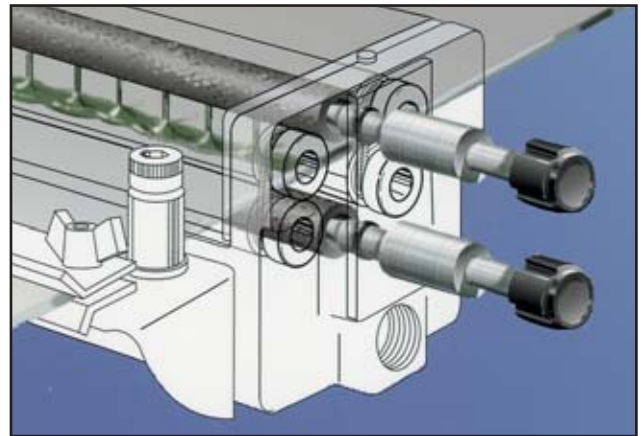
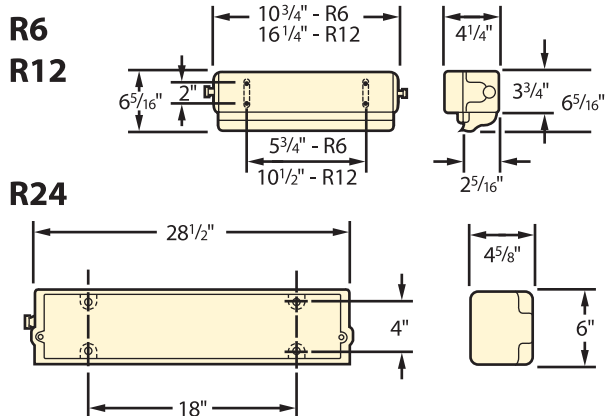

Dual manifold needle valves provide finger tip adjustment of the lubrication flowing on to the stock. This control allows operation at various production speeds.

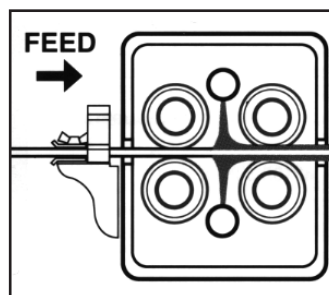

Independent manifold valves permit application of lubricant to either top, bottom or both sides simultaneously. There is no waste with a Graymills Stocklube System because unused lubricant is recirculated.

Stocklube Systems



Combine these for complete System Model Number

MAXIMUM STOCK WIDTH	HEAD ONLY MODEL NO.	PUMP & TANK MODEL NO.	MOTOR HP	MOTOR SUFFIX	MAXIMUM VISCOSITY	TANK CAPACITY GALLONS	TYPE OF PUMP
6"	R6 STEEL ROLLERS	6FM68H	1/8	A, B, F	500	6	CENTRIFUGAL
		6SG2	1/8	A, B, F	5,000	6	GEAR
	R6U URETHANE ROLLERS	11SG4	1/4	E, F	5,000	10	GEAR
		11SG4	1/2	E, F	5,000	10	GEAR
12"	R12 STEEL ROLLERS	6FM68H	1/8	A, B, F	500	6	CENTRIFUGAL
		11FM68H	1/8	A, B, F	500	10	CENTRIFUGAL
	R12U URETHANE ROLLERS	6SG2	1/8	A, B, F	5,000	6	GEAR
		11SG4	1/4	E, F	5,000	10	GEAR
24"	R24 STEEL ROLLERS OR R24U URETHANE ROLLERS	11FM68H	1/8	A, B, F	500	10	CENTRIFUGAL
		11SG4	1/4	E, F	5,000	10	GEAR
		11SG4	1/2	E, F	5,000	10	GEAR

*Note: Other pump and tank combinations available.

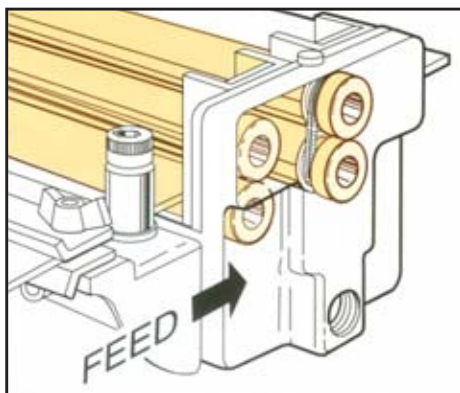

Six-inch and twelve-inch models have two sets of rollers. These units also have inlet roller guides adjustable for stock widths as narrow as one-inch to facilitate the feeding of sheet stock.

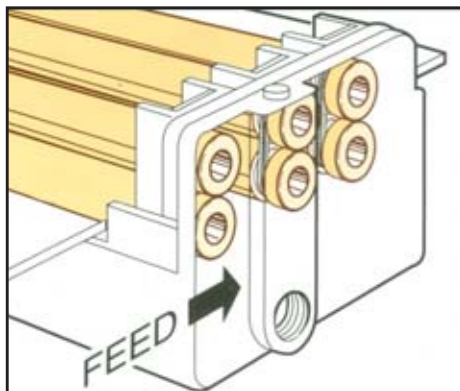

Twenty-four-inch models have three sets of rollers to assure even distribution of the lubricant on larger sheet widths.

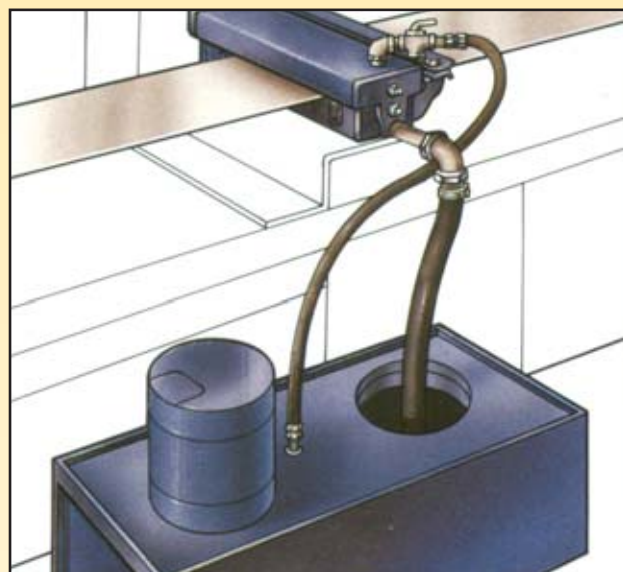

Stocklube units are easily installed in a variety of positions on all types of presses. The preferred position is between the roll feed mechanism and the fabricating equipment.

VOLTAGE SUFFIX CHART

Suffix	A	B	E	F	Z	GAM/GAMC
Voltage	115	230	115/230	230/460	575	Air motor
Hertz	50/60	50/60	50/60	50/60	60	
Phase	1	1	1	3	3	

Oil Separator

The Graymills Oil Separator is designed for the separation and removal of emulsified and free oil from water-based machine tool coolants used in CNC machining centers and lathes. It is effective for tramp oil separation in machine-tool systems using water-based synthetic and semi-synthetic coolant.



OSEP 5/5S SERIES FEATURES

The OSEP-5 uses simple, mechanical separation to achieve a very high level of oil removal. Unlike traditional oil skimmers which are very inefficient, the OSEP-5 works continuously even while the machine is in operation.

Easy to install and requiring low maintenance, the OSEP-5 is economical to operate, has no moving parts and requires no separate power source when installed on a recirculating system. The system extends solution life, returning virtually oil-free fluid back to the coolant sump typically reducing oil to parts per million. Its large capacity chamber can handle large sumps with ease and can even be used with centralized coolant systems holding hundreds of gallons of coolant.

It will extend the life and quality of your coolant, prevent rancidity from anaerobic bacterial growth and is a cost effective addition for any machine shop or production facility. Available in mild steel (OSEP-5) or stainless steel (OSEP-5S) the system is built to last with construction of heavy gauge steel that is MIG welded and leak tested.

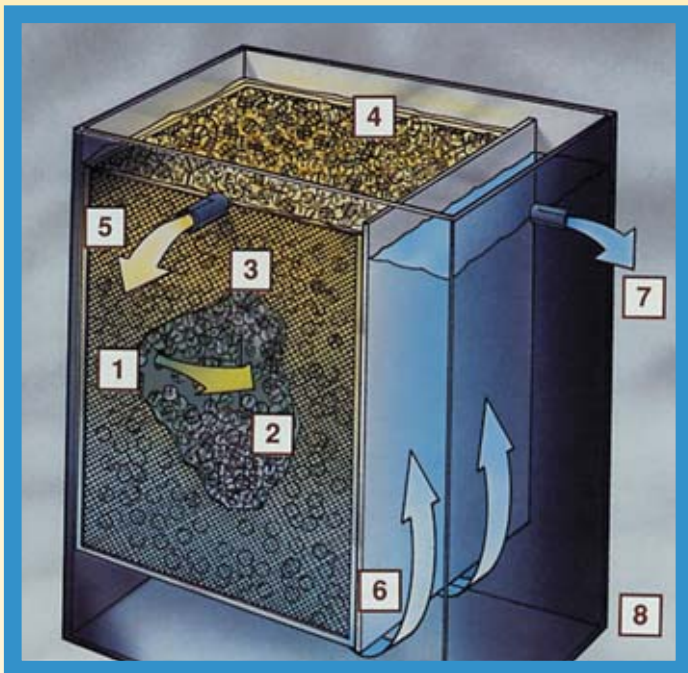

OSEP-5/5S

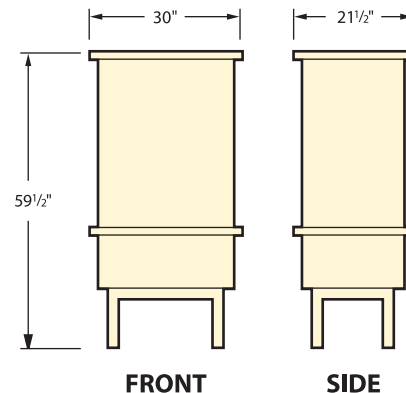

OSEP 5/5S ORDER INFORMATION

DIMENSIONS	30" W x 21 1/2" D x 59 1/2" H
CAPACITY	120 Gallons
FLOW RATE	5 GPM

Notes: The oil separator is intended for water-based solutions and will not function with solvent-based or chemically emulsified fluids. Systems that do not have a recirculation pump require the separator to be equipped with its own pump. Consult factory for details.

HIGHLY EFFICIENT OIL REMOVAL

1. Adjustable inlet valve controls flow at five GPM to assure sufficient separation time.
2. Oily solution enters larger separator chamber.
3. Emulsified oil adheres to polypropylene spheres which are non-wearing and require no replacement.
4. Formed droplets separate and rise to the surface to form an oil layer.
5. Oil layer gravity feeds to recovery container for proper disposal, reuse or reclamation.
6. Separated oil-free coolant fluid passes under baffle to second chamber.
7. Virtually oil-free coolant flows back to principle reservoir.
8. Bottom drain facilitates clean-out when required.

Bed Filter/Magnetic Separator/Coolant Tank

This durable, hard-working, automatic system is designed to keep your cutting, grinding, drilling and milling machinery operating at peak performance while keeping the coolant free of swarf, dirt, chips, grit and other machining by-products. By filtering out harmful contaminants, coolant life is greatly extended saving both coolant replacement and labor change-out costs.



Bed Filter/Coolant tank

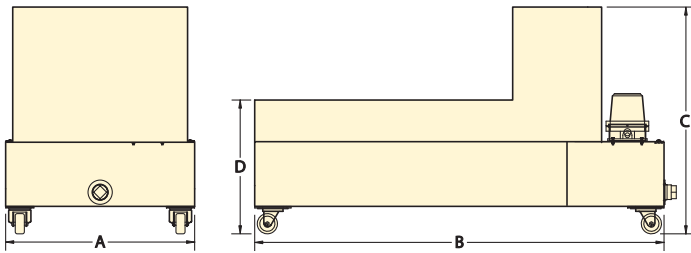

BED FILTER ORDER INFORMATION

BED FILTER*	BF40	BF80
Width (A)	21 ⁵ / ₈ "	21 ¹ / ₂ "
Length (B)	41"	61"
Overall Height (C)	28 ¹ / ₄ "	28 ¹ / ₄ "
Inlet Height (D)	17"	17"
Motor	Gear 25W	Gear 40W
Filter Paper m Width	20"	20"

TANK*	CT40	CT80
Width	23 ³ / ₈ "	23 ³ / ₈ "
Length	50 ⁵ / ₈ "	70 ¹ / ₂ "
Height	8"	8"
Capacity	35 Gallon	50 Gallon
Pump	230/460V/3ph	230/460V/3ph
HP	1/8	1/4
Max Flow Rate	10 GPM	20 GPM

* Custom colors for OEM applications are available for tank, filter and separator.

BED FILTER/MAGNETIC SEPARATOR/COOLANT TANK SPECIFICATIONS

Rugged, heavy-duty Bed Filter/Coolant Tank combination is available in 35 and 50 gallon tank sizes. Make the right decision for your shop floor—choose the high performance Bed Filter/Coolant Tank/Magnetic Separator from Graymills.

Rugged, durable construction

Constructed of 14 gauge steel, this reliable Bed Filter/Coolant tank is built to give years of service on your shop floor.

Extra-strength chain links

Industrial strength chain links resist binding and offer trouble-free and kink-free operation. Heavy center rods add durability and strength.

Float and shut-off mechanism

Specially designed float mechanism is engaged when the dirty fluids blind off the filter paper. A switch starts the motor which moves the filter media along replacing it with clean filter media to allow the filtration process to continue—automatically!

Larger sizes available. Consult factory for details.

Magnetic Separator

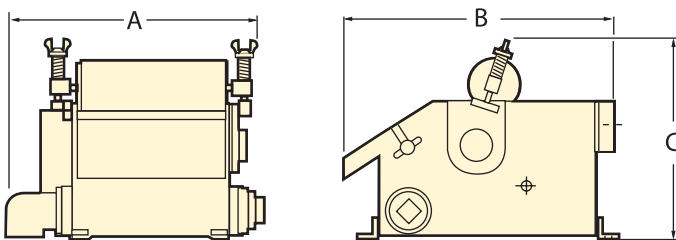

MAGNETIC SEPARATOR ORDER INFORMATION

MAGNETIC SEPARATOR*	MS40	MS80
Width (A)	12.0"	15.0"
Length (B)	18.5"	20.9"
Height (C)	11.8"	13.6"
Motor	230/460V/3ph	230/460V/3ph

* Custom colors for OEM applications are available for tank, filter and separator.

MAGNETIC SEPARATOR

The Magnetic Separator may be added to the Bed Filter System for multi-layer protection or used alone where there is ferrous metal contamination. The Magnetic Separator removes ferrous metal debris from the sediment permitting simpler disposal of filter media.

- Simple flow-through design easily retrofits to existing systems.
- No filter media required so operating cost is low.



Accessories PUMPING SYSTEMS

Graymills offers a selection of products to help you complete and enhance your pump/tank system or pumping application.

MOUNTING ADAPTERS

TN SERIES

C-27667

Split center column flange. Mounts around column of all TN models. Bolt circle: 9¹/₂" or 9³/₄".

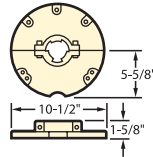

615-13597

Mounting plate, for TN 40 and 50 Series. Bolt circle: 14". **Must be factory installed.**

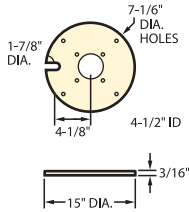

C-26700

Split column bracket bolts around pump column of all TN, DSW and ESW Series pumps.

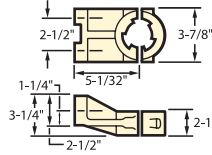

C-27670

Split offset column flange. Mounts around column of all TN models. Bolt circle: 9³/₄".

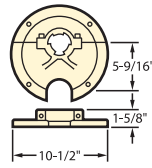

620-20826

Mounting plate, for TN 30, 40, and 50 Series. Bolt pattern, square: 10¹/₂" x 10¹/₂". **Must be factory installed.**

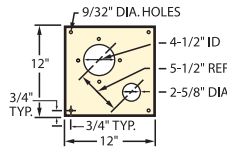

C-12499

Split column bracket bolts around pump column of all TN models. Bolt circle: 7¹/₂" or 7³/₄". Allow 2¹/₂" between base of motor and bottom of flange.

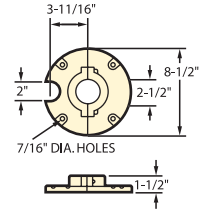

615-31890

Mounting plate, for all TN 30 models. Bolt circle: 9¹/₂". **Must be factory installed.**

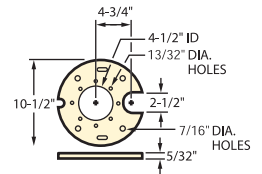

620-20827

Mounting plate, for TN 60 and 70 Series. Bolt pattern, square: 12¹/₂" x 12¹/₂". **Must be factory installed.**

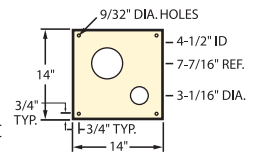

LV SERIES

615-21171-81

Mounting plate, stainless steel. For all LV models. Bolt circle: 9¹/₂" or 7³/₄". **Must be factory installed.**

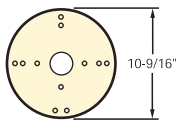

615-21432-81

Mounting plate, stainless steel. For all LV models. Bolt circle: 4¹/₂" or 7³/₄". **Must be factory installed.**

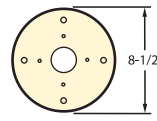

C-21217

Split column flange, bolts around pump column. Fits all LV models. Bolt circle: 7⁷/₈".

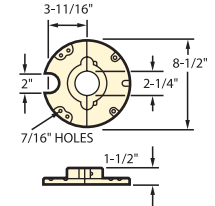

HSP, BSW/CSW, TNRSS, HP, MSPR

MP1

Split Casting For HSP pumps.

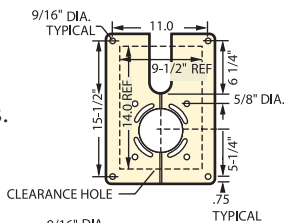

420-27800

Split Casting Mounting plate. Bolt pattern. 13" x 13". Fits all HP models.

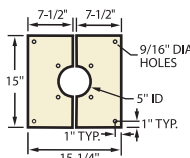

C-29096-81

Split mounting plate, stainless steel. Fits all TNRSS models. Can be factory or user installed.

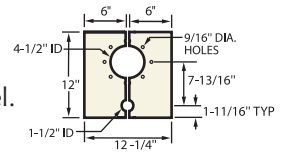

MC1

Split Casting For HSP pumps.

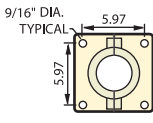

C-26699

Split column bracket bolts around CSW Series columns.

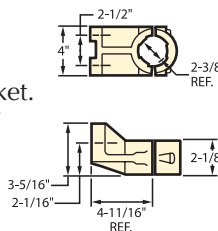

C-26705

Split column bracket bolts around BSW Series columns.

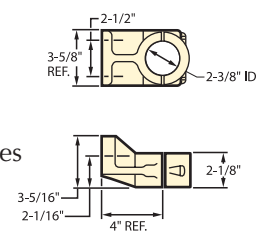



SUPERFLO LIQUID FILTERS (EFS/EFL)

Permanent magnet and reusable stainless steel cartridge trap ferrous particles, scale and contaminants to prevent costly damage. Collects up to 20 cu. in. of material without pressure drop. Available in 11¹/₄" length single cartridge model (EFS) or 19³/₄" length dual cartridge model (EFL). Teflon®-coated cast aluminum housing. Reusable stainless steel cartridges available in 30 (590), 60 (250), 100 (149), and 150 (99) mesh (micron). 1" NPT intake. Dual 1" NPT discharge ports; 3/4" NPT reducers provided.

SURGE SUPPRESSOR/FILTER FOR DOUBLE DIAPHRAGM SERIES PUMPS (EDPSF)

Enables smooth filtered flow from reciprocating-type pumps. Comes with pinch valve and is available in 30, 60, 100, and 150 mesh filtration. Teflon® coated cast aluminum housing with reusable stainless steel cartridge. 1" NPT bottom intake and dual 3/4" NPT discharge ports. Corrosion-resistant Teflon® finish. See price list for model numbers. Available in 30 (590), 60 (250), 100 (149), and 150 (99) mesh (micron).

UNIVERSAL MOUNTING BRACKETS (C-28953)

Cast aluminum multi-purpose bracket for filters and surge suppressors.

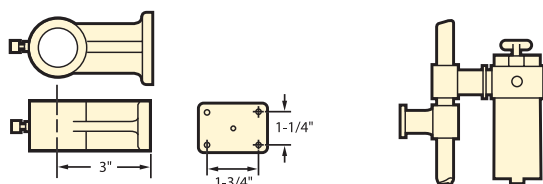

C-28953



A.



B.



C.



D.



E.

**FRL-1
FRL-2**

A. TANK LINERS

Reusable tank liner features built-in sump to conform to Graymills' standard round tanks. Made of high-density polyethylene. Fits Graymills' 10, 20 and 30 gallon round tanks. Disposable 2 and 5 gallon liner without sump also available. See price list for part numbers.

B. DRUM COVER

Two-piece cover for use with TNR 36" pumps and DPH-50 pumps. Available for 55 gallon drums.

C-35858: 55 gal. cover for TN30 Series

C-37237: 55 gal. cover for TN40 Series

C. MIX55-PAM

For use on 30 and 55 gallon drums. High torque piston air motor blends at low 500-540 RPM with air consumption of 5 CFM at 80 psi. Features include: adjustable mixing speed, mixing viscosities up to 10,000 CPS, reversible impeller direction, adjustable mounting clamp. Other size mixers available for standard Graymills tanks.

D. NOZZLES AND COOLANT LINES

Replacement/option for pumping units. Can be ordered assembled as shown or in separate components. Consult price list for various sizes available.

E. FILTER/REGULATOR/LUBRICATOR

Removes contaminants and moisture from compressed air while adding oil mist for lubrication. Available for air motors with 1/8" or 1/4" inlet and outlet. 1/4" model includes 0-160 PSI gauge. 1/8" "piggyback"- style filter regulator also available for 1/2" Double Diaphragm pump.

To see our diversified line of Parts Washers and Accessories visit
www.graymills.com



Rugged construction of our Solvent parts washers range in size from bench-top to large, feature packed immersion models provide years of trouble-free service.



High Pressure spray cabinets for non-abrasive cleaning of parts with intricate shapes and blind holes.



Total immersion cleaning, with agitation and optional Graymills Superflo[®] pump jet action, LiftKleens are available in solvent, aqueous and ultrasonic models.



Environmentally-friendly, Aqueous parts washers available in plastic or metal construction are designed for ease of use and maximum cleaning performance. Models available with bioremediation technology.

Graymills

Worldwide Distribution and Product Support

GM100-0907

Graymills Corporation
3705 N. Lincoln Ave.
Chicago, Illinois 60613-3594
Phone: 1-888-GRAYMILLS

www.graymills.com

© 2007 Graymills Corporation, Chicago