

## IMPIEGHI

- Le pompe serie BMF sono pompe volumetriche ad ingranaggi monoblocco adatte per il trasferimento di liquidi viscosi e privi di sostanze solide in sospensione.
- Sono pompe autoadescanti e vengono fornite con i motori a 4 poli per liquidi con viscosità fino a 10° E e con motori a 6 poli per liquidi con viscosità superiori.
- Vengono impiegate per il trasferimento di olio combustibile, prodotti petroliferi, prodotti cosmetici, prodotti alimentari, vernici, oli lubrificanti, ecc.

## COSTRUZIONE

- L'esecuzione standard delle pompe serie BMF è in ghisa con ingranaggi ed alberi in acciaio, tenuta meccanica in Viton.
- Le bocche di aspirazione e mandata sono dello stesso diametro e disposte sullo stesso asse.
- Nella versione standard possono funzionare con liquido alla temperatura max 140°C.
- Per temperature superiori o per applicazioni speciali si possono fornire flangiate per applicare a motori forma B3/B14 oppure B3/B5.
- Sulla mandata della pompa è possibile montare una valvola di sicurezza by-pass che protegga la pompa da pericolose sovrappressioni.
- La valvola by-pass è del tipo a ricircolo interno e si può tarare agendo sulla vite di regolazione.
- Il senso di rotazione è orario guardando dalla parte della pompa, la mandata è sulla sinistra (dalla parte della valvola by-pass), l'aspirazione è sulla destra.
- Le pompe BMF con tenuta appropriata possono essere reversibili.

## ESECUZIONI

BF - BFZ - BFX = pompe ricavate dalla serie BMF senza motore.

BFC - BFCZ - BFCX = pompe con campana per accoppiamento a motore forma B5.

BMFZ = esecuzione in bronzo per liquidi alimentari.

BMFX = esecuzione inox AISI 316 per liquidi speciali.

BCF - BCFZ - BCFX = pompe monoblocco nelle varie metallurgie con motore monofase.

.../6 indica motore a 6 poli.

V1 - V2 indicano la valvola by-pass.

Per liquidi speciali è consigliabile consultare il nostro ufficio tecnico.

## MOTORE

I motori sono del tipo ad induzione.

Isolamento classe F.

Protezione IP 54.

Albero speciale prolungato.

## ESECUZIONI SPECIALI

- Tensioni speciali, tropicalizzazione.
- Protezione IP 55.
- Motori ADPE.

## APPLICATIONS

- The BFM series are volumetric pumps with single-impelled gearing suitable for transferring of viscous and devoid of suspended solid substances liquids.
- These are selfpriming pumps and are supplied with 4-pole motors for liquids bearing a viscosity up to 10° E and with 6-pole motors for liquids with higher viscosity.
- They are employed for the transferring of fuel oil, petroliferous products, cosmetic items, foodstuffs, varnishes, lubricant oils, etc.

## CONSTRUCTION

- The standard execution of the BMF series pumps is in cast iron with steel gearing and shafts; mechanical seal in Viton.
- The suction and delivery nozzles have the same diameter and are on the same axis (in-line).
- In the standard version they can operate with a maximum liquid temperature of 140°C.
- For higher temperatures or particular applications the pumps can be supplied flanged to allow connection with B3/B14 or B3/B5 motor forms.
- It is possible to fix on the pump delivery an over-pressure by-pass valve thus protecting the pump from dangerous overpressures.
- The by-pass valve is of the inner recycle kind and it can be calibrated by acting on the adjusting screw.
- The sense of rotation is right-hand looking from the pump side, the delivery is on the left (from the by-pass valve side), the suction is on the right.
- The BMF pumps with suitable sealing can be reversible.

## EXECUTIONS

BF - BFZ - BFX = pumps derived from the serie BMF without motor.

BFC - BFCZ - BFCX = pumps BF with bell for coupling to motor form B5.

BMFZ = execution in bronze for alimentary liquids.

BMFX = execution in AISI 316 stainless steel for particular liquids.

BCF - BCFZ - BCFX = single-impelled pumps made in different metals with single-phase motor.

.../6 shows 6-pole motor.

V1 - V2 show the by-pass valve.

For particular liquids we advise you to contact our technical department.

## MOTOR

The motors are of the induction type.

Class F insulation.

IP 54 protection.

Special extended shaft.

## SPECIAL FEATURES

- Particular voltages, tropicalization.
- IP 55 protection.
- ADPE motors.

## UTILISATIONS

- Les pompes série BMF sont des pompes volumétriques à engrenages monoblocs aptes au transfert de liquides visqueux et privés de substances solides en suspension.
- Il s'agit de pompes automorçantes qui sont fournies avec moteurs à 4 poles pour liquides avec une viscosité jusqu'à 10° E et avec moteurs à 6 poles pour liquides à viscosité majeure.
- Ces pompes sont utilisées pour le transfert d'huiles combustibles, produits pétroliers, produits cosmétiques, produits alimentaires, peintures, huiles lubrifiants, etc.

## CONSTRUCTION

- L'exécution standard des pompes série BMF est en fonte avec engrenages et arbres en acier, garniture mécanique en Viton.
- Les orifices d'aspiration et refoulement ont le même diamètre et sont situés sur le même axe (exécution in-line).
- Dans la version standard les pompes peuvent marcher avec liquides à la température maximale de 140°C.
- Pour des températures supérieures ou pour des emplois particuliers on peut fournir les pompes bridées pour l'accouplement à moteurs en forme B3/B14 ou bien B3/B5.
- Sur le refoulement de la pompe on peut monter une soupape de surpression by-pass qui protège la pompe des surpressions dangereuses.
- La soupape by-pass est du type à recirculation et on peut la tarer en jouant sur la vis de régulation.
- Le sens de rotation est horaire en regardant du côté de la pompe, le refoulement est à gauche (du côté de la soupape by-pass), l'aspiration est à droite.
- Les pompes BMF, avec garniture apte, peuvent être réversibles.

## EXECUTIONS

BF - BFZ - BFX = pompes dérivées de la série BMF sans moteur.

BFC - BFCZ - BFCX = pompes BF avec lanterne pour accouplement à moteur en forme B5.

BMFZ = exécution en bronze pour liquides alimentaires.

BMFX = exécution en acier inoxydable AISI 316 pour liquides particuliers.

BCF - BCFZ - BCFX = pompes monobloc en différents métaux avec monophasé.

.../6 indique moteur à 6 poles.

V1 - V2 indiquent la soupape by-pass.

Pour des liquides particuliers il vaut mieux consulter notre département technique.

## MOTEUR

Les moteurs sont à induction.

Isolation Classe F.

Protection IP 54.

Arbre étendu special.

## EXECUTIONS SPECIALES

- Voltages particuliers, tropicalisation.
- Protection IP 55.
- Moteurs ADPE.

## PRESTAZIONI - PERFORMANCES

MOTORE A 1400 GIRI/MIN - R.P.M. 1400						MOTORE A 900 GIRI/MIN. - R.P.M. 900					
PREVALENZA - HEAD - HAUTER											
5 ATE				10 ATE				10 ATE			
TIPO TYPE	PORTATA DELIVERY DEBIT lt/h	POTENZA POWER PUISSANCE		TIPO TYPE	PORTATA DELIVERY DEBIT lt/h	POTENZA POWER PUISSANCE		TIPO TYPE	PORTATA DELIVERY DEBIT lt/h	POTENZA POWER PUISSANCE	
		KW	HP			KW	HP			KW	HP
BMF2	120	0.09	0.12	BMF2M	90	0.13	0.18	-	-	-	-
BMF3	210	0.13	0.18	BMF3M	160	0.18	0.25	-	-	-	-
BMF4	240	0.18	0.25	BMF4	210	0.18	0.25	-	-	-	-
BMF5	320	0.26	0.35	BMF5	300	0.26	0.35	BMF5/6	200	0.18	0.25
BMF10	600	0.26	0.35	BMF10M	580	0.37	0.5	BMF10/6	400	0.26	0.35
BMF15	900	0.37	0.5	BMF15M	850	0.55	0.75	BMF15/6	600	0.37	0.5
BMF25	1500	0.55	0.75	BMF25M	1400	0.75	1	BMF25/6	1000	0.55	0.75
BMF35	2100	0.75	1	BMF35M	2000	1.1	1.5	BMF35/6	1400	0.75	1
BMF50	3000	1.1	1.5	BMF50M	2900	1.5	2	BMF50/6	2000	1.1	1.5
BMF60	3600	1.5	2	BMF60M	3400	1.8	2.5	BMF60/6	2400	1.1	1.5

Prestazioni Teoriche con Olio 6° E  
Tolleranza +2% -5%

- Per viscosità fino a 10° E pompa con motore a 1400 Giri/Min.
- Per viscosità da 10 a 50° E pompa con motore a 900 Giri/Min.
- Per viscosità superiori interpellare il nostro ufficio tecnico.

Theoric Performances with oil 6° E  
Tolerances +2% -5%

- For viscosity up to 10° E pump with motor to 1400 R.P.M.
- For viscosity from 10 to 50° E pump with motor to 900 R.P.M.
- For higher viscosities please apply to our technical department.

Performances Théoriques avec huile 6° E  
Tolerances +2% -5%

- Pour viscosité jusqu'à 6° E pompe avec moteur à 1400 R.P.M.
- Pour viscosités de 10 à 50° E pompe avec moteur à 900 R.P.M.
- Pour viscosités supérieures veuillez consulter notre département technique.

**- REGIME DI ROTAZIONE CONSIGLIATO IN FUNZIONE ALLA VISCOSITÀ DEL LIQUIDO**

**- ADVISED ROTATION SPEED FOLLOWING THE VISCOSITY OF LIQUID**

**- VITESSE DE ROTATION CONSEILLÉE EN FONCTION DE LA VISCOSITÉ DU LIQUIDE**

GIRI/MIN. R.P.M.	1'500	1'000	750	600	500	300	200
VISCOSITÀ mm <sup>2</sup> /s (cst)	200	500	1'000	2'000	3'200	10'000	20'000



# DIMENSIONI E PESI - DIMENSIONS AND WEIGHTS - DIMENSIONS ET POIDS

**BF**

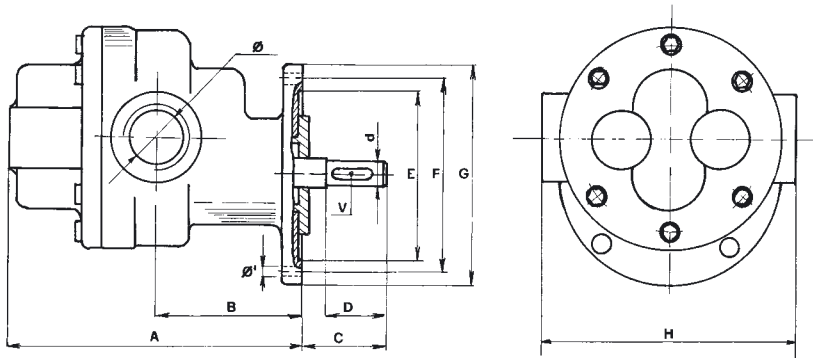

**BFC**

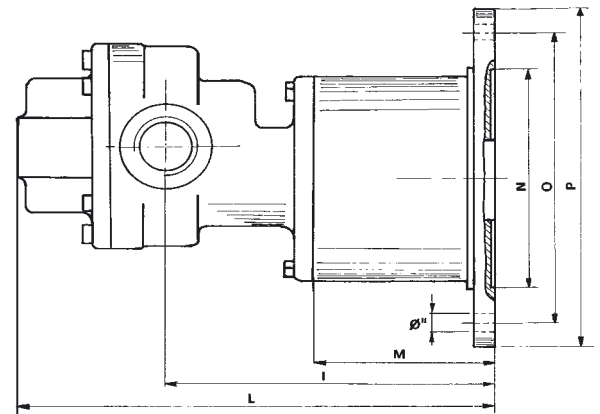

TIPO TYPE	MOTORE GR	A	B	C	D	E	F	G	H	I	L	M	N	O	P	Ø	Ø1	Ø2	d	V	Kg
BF-BFC 5	71	98	50	50	28	90	106	120	110	173	216	118	110	130	160	1/2"	8.5	11.5	12	4	4.3
BF-BFC 10		115	60	50					115	183	233					5					
BF-BFC 15	80	124	60	44	38	90	106	120	117	193	256	123	130	185	200	3/4"	8.5	11.5	13	5	5.2
BF-BFC 25		133	70	47					134	199	276					5.5					
BF-BFC 35	90	153	76	44	50	90	106	120	134	199	276	123	130	185	200	1"	8.5	11.5	13	5	7
BF-BFC 50		153	76	44					134	199	276					7.2					
BF-BFC 60		162	78	58					162	78	58					285					1 1/4"

## DESCRIZIONE - DESCRIPTION - DESCRIPTION

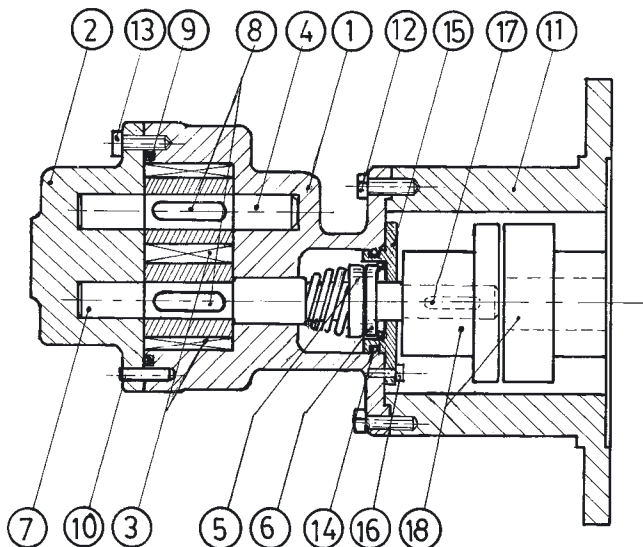

POS	DESCRIZIONE	DESCRIPTION	DESCRIPTION
1	Corpo pompa	Pump Body	Corps Pompe
2	Coperchio	Cover	Couvercle
3	Ingranaggi	Gears	Engrenages
4	Albero secondario	Driven shaft	Arbre
5	Tenuta meccanica	Mechanical seal	Garniture mécanique
6	Controfaccia tenuta	Seal matching surface	Contre-face garniture
7	Albero primario	Shaft	Arbre
8	Chiavetta	Key	Clavette
9	O-ring	O-ring	O-ring
10	Spine	Plug	Fiche
11	Campana accoppiamento	Coupling belt	Lanterne
12	Viti TE	Screw	Vis TE
13	Viti TCE	Socket head screw	Vis TCE
14	O-ring	O-ring	O-ring
15	Coperchio tenuta	Mechanical seal cover	Couvercle pour garniture
16	Viti TCE	Socket head screw	Vis TCE
17	Chiavetta giunto	Joint key	Clavette joint
18	Giunto elastico	Elastic joint	Joint elastique

## DIMENSIONI E PESI - DIMENSIONS AND WEIGHTS - DIMENSIONS ET POIDS

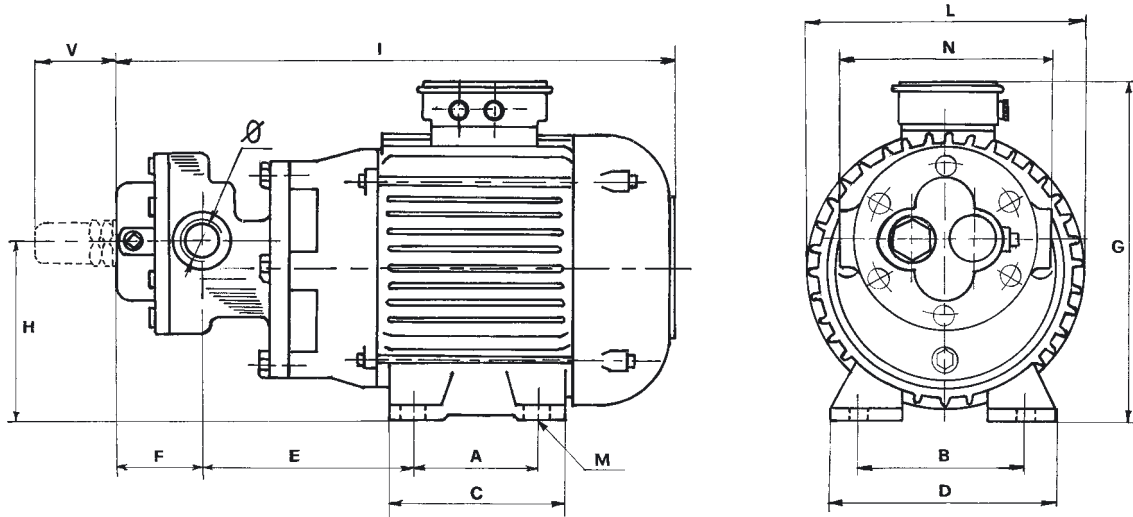

TIPO TYPE	POTENZA HP		∅	A	B	C	D	E	F	G	H	I	L	M	N	V	Kg	
	4 POLI	6 POLI																
BMF2	0.12	-	3/8"	71	90	86	117	66	50	154	68	257	108	6	85	40	6.2	
BMF3	0.18	-		80	100	100	120	70	53	164	74	270	121	7			6.6	
BMF4	0.25	-		80	100	100	120	70	57		276	7		6.9				
BMF5	0.35	-	1/2"	80	100	100	120	90	53	164	78	296	121	7	110	48	7.7	
BMF5/6	-	0.25		90	112	109	135			187	86	314	143				10.2	
BMF10	0.35	-	3/4"	80	100	100	120	99	59	164	78	314	121	7	115	48	8.5	
BMF10M	0.5	-		90	112	109	135			187	86	334	143				9	11.2
BMF10/6	-	0.35		90	112	109	135			187	86	343	143				9	11.2
BMF15	0.5	-	3/4"	90	112	109	135	110	69	187	86	343	143	9	115	48	10.8	
BMF15M	0.75	-		100	125	125	154			210	95	365	162				14.2	
BMF15/6	-	0.5		90	112	109	135			187	86	365	132				9	11.2
BMF25	0.75	-	3/4"	90	112	109	135	120	71	210	95	376	132	9	117	48	12.4	
BMF25M	1	-		100	125	125	154			210	95	376	132				9	11.2
BMF25/6	-	0.75		100	125	125	154			210	95	376	132				9	11.2
BMF35	1	-	1"	100	125	125	154	132	75	210	104	395	162	9	134	48	16.5	
BMF35M	1.5	-		125	140	150	170			230	112	441	182				20.1	
BMF35/6	-	1		100	125	125	154			210	104	441	162				9	11.2
BMF50	1.5	-	1"	100	125	125	154	142	85	210	104	441	162	9	134	48	17.5	
BMF50M	2	-		125	140	150	170			230	112	452	182				21.7	
BMF50/6	-	1.5		125	140	150	170			230	112	452	182				9	11.2
BMF60	2	-	1 1/4"	125	140	150	170	142	85	230	112	452	182	9	122	48	22	
BMF60M	2.5	-		125	140	150	170			230	112	452	182				9	11.2
BMF60/6	-	1.5		125	140	150	170			230	112	452	182				9	11.2

## DESCRIZIONE - DESCRIPTION - DESCRIPTION

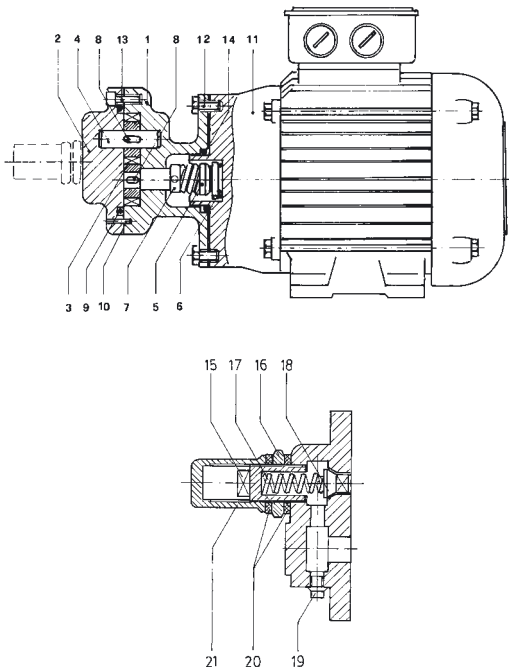

POS.	DESCRIZIONE	DESCRIPTION	DESCRIPTION
1	Corpo pompa	Pump Body	Corps Pompe
2	Coperchio	Cover	Couvercle
3	Ingranaggi	Gears	Engrenages
4	Albero secondario	Driven shaft	Arbre
5	Tenuta meccanica	Mechanical seal	Garniture mécanique
6	Controfaccia tenuta	Seal matching surface	Contre-face garniture
7	Ghiera	Ring nut	Embout
8	Chiavetta	Key	Clavette
9	O-ring	O-ring	O-ring
10	Spina	Plug	Fiche
11	Motore elettrico	Electric motor	Moteur
12	Viti TE	Screw	Vis TE
13	Viti TC	Socket head screw	Vis TC
14	O-ring	O-ring	O-ring
15	Bussola	Bush	Boussole
16	Controdado	Lock nut	Contre Écrou
17	Molla	Spring	Ressort
18	Fungo	Plug	Bouchon
19	Tappo	Plug	Bouchon
20	Rondella	Grommet	Rondelle
21	Cappello By-pass	By-pass cover	Couvercle by-pass