

# HEADHUNTER

INTEGRATED MARINE SYSTEMS



TOILETS



WATER PRESSURE SYSTEMS

WASTE TREATMENT & MANAGEMENT



FLUID LEVEL MONITORING



AND MORE!



# Royal Flush Superbowl



SBS-5\* Sand



SBS-9\* Black



SBS-3\* Bone



SBS-0\* White



- 5 year warranty
- No complicated mechanical equipment in the discharge plumbing

- Flushes rags, quarters, and panty hose
- Intuitive touch activated switch
- Labor and space saving installation

All Royal Flush Toilets are built around a simple, no nonsense, water jet macerator. Reliability proven over two decades in a variety of Royal Flush models is demonstrated at trade shows around the world by repeatedly flushing rags and quarters while spectators stare in disbelief.

All Royal Flush Toilets operate on the following principle. Pressurized water is accelerated through a jet to macerate and discharge the waste. There are no complicated mechanical sewage devices to maintain. Consumption of less than 1 gallon per flush strikes a balance between water conservation and effective odor control. Each and every Royal Flush is designed, manufactured and tested to provide years of trouble free service.

Pressurized water is supplied by either a dedicated pump (defined as a single station) or by a pumping station shared by multiple toilets (defined as a central system). No matter which method you choose to supply the water, you'll need a station which includes a seat, a bowl, a touch activated time delay switch, mounting hardware, a vented loop, and of course our unequalled 5 year warranty.

The Royal Flush Superbowl Station is the designers choice, integrating form with function without bulky tanks, valves or foot pedals. It has the smallest foot print with the largest seating area available in any toilet and is compatible with fresh or salt water.

Inlet = 1 inch - 26mm

Outlet = 1-1/2 inch I.D./50mm O.D. pipe, or 1-7/8 inch/48mm hose

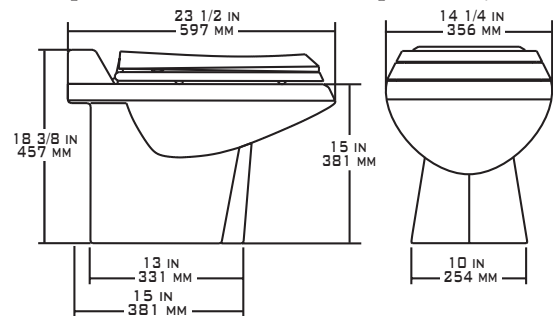

\*Note: please specify "C" or "G" at end of part number for Chrome or Gold trim



## Quality Construction

All Royal Flush toilets are constructed of vitreous china, and marine grade materials. Each toilet is 100% visually inspected and pressure tested prior to packaging by factory trained technicians.

## Simply Touch to Flush

All Royal Flush toilets include our innovative "Go-n-Touch" tactile feedback switch. These easy to use waterproof switches conform to our reliable intuitive design standard.

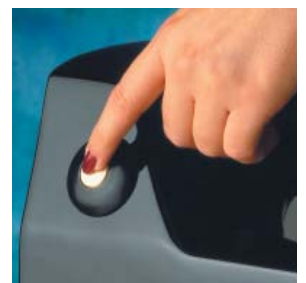



**The Royal Flush NeoClassic** is functionally identical to earlier Royal Flush models. The one-piece Neoclassic represents the addition of an elegantly styled bowl in a household size model. Ideal for yachts in the 65' and under class, as well as tight quarters on any vessel. Available in White, Bone, Sand, or Black. Each toilet has a 5 year warranty and all colors match Kohler fixtures.

Commercial models available.

Inlet = 1 inch - 26mm

Outlet = 1-1/2 inch - 38mm pipe or 1-7/8 inch - 48mm hose

- NCS-0\* NeoClassic White
- NCS-3\* NeoClassic Bone
- NCS-5\* NeoClassic Sand
- NCS-9\* NeoClassic Black

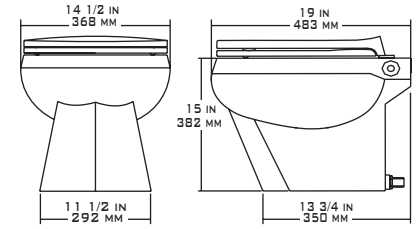

\*Note: please specify "C" or "G" at end of part number for Chrome or Gold trim



**The Royal Flush Classic Station (RFS)** utilizes the same jet macerator technology as the Royal Flush Superbowl but in a more compact package. The RFS features an anatomically correct china bowl and is available in three discharge configurations which are defined as you face the toilet; right (R), left (L), and aft (A). Station consumes less than 1 gallon per flush.

- RFS-A-0 Classic Station-Aft Discharge
- RFS-L-0 Classic Station-Left Discharge
- RFS-R-0 Classic Station-Right Discharge

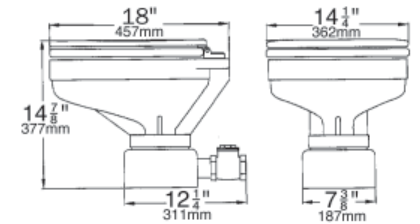

**The Royal Flush Bidet** adds a touch of European elegance to your bathroom. Designed to complement the futuristic lines of Headhunter's NeoClassic and Superbowl toilets, our bidet will show your subtle sophistication, while providing unique and simple functionality. The Royal Flush Bidet is available in the same fine porcelain and designer color selection as our toilets, with a choice of gold-plated or chrome-plated solid brass faucet's. All colors match Kohler fixtures.

- BDS-0\* White Bidet
- BDS-3\* Bone Bidet
- BDS-5\* Sand Bidet
- BDS-9\* Black Bidet

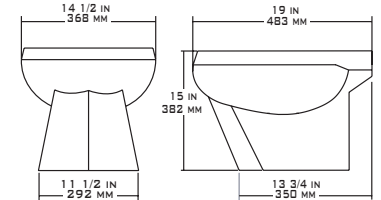

\*Note: please specify "C" or "G" at end of part number for Chrome or Gold trim



**Bidet Attachments** are available in chrome or gold finish, and cold water only or cold and hot water. Spout swivels under the seat when not in use, swings out for conventional bidet convenience.

- BDA-C-HC Headhunter Chrome Bidet Attachment Hot & Cold
- BDA-G-HC Headhunter Gold Bidet Attachment Hot & Cold

\*Note: requires special seat call Headhunter for details



**Carbon Fiber Royal Flush Station** With the same dimensions as the NeoClassic and using the same water jet technology as our porcelain models, this is the lightest Royal Flush toilet in the world weighing in at a mere 12 lbs. Great for high speed patrol boats, for those in a hurry to go, racing enthusiasts, and the person who has everything else. Weighs in at over 40 lbs. less than standard models. Call to order.

For dimensions: see NeoClassic

- CFS Carbon Fiber Royal Flush Station

# Royal Flush Aero



RFA-0\* White



RFA-3\* Bone



RFA-5\* Sand



RFA-9\* Black

## The Wall Mounted Royal Flush Aero

Designed specifically for luxury accommodations, the wall mounted Royal Flush Aero combines an elegant looking, comfortable, elongated toilet with patented and proven Headhunter technology. The result: a reliable toilet that matches the tasteful décor of any vessel. The Aero's unique and carefully considered design yields a comfortable elongated seat in the same space that competitors deliver small round bowls. Like all of Headhunter's Royal Flush toilets, the Aero is available in four designer colors; white, black, bone and sand, matching Kohler fixtures. Installation is easier and operation is quieter as there's no vacuum nor macerator pumps.

- Sleek, Stylish Design
- Elongated Seat for Comfort
- Wall Mount

\*Note: please specify "C" or "G" at end of part number for Chrome or Gold trim

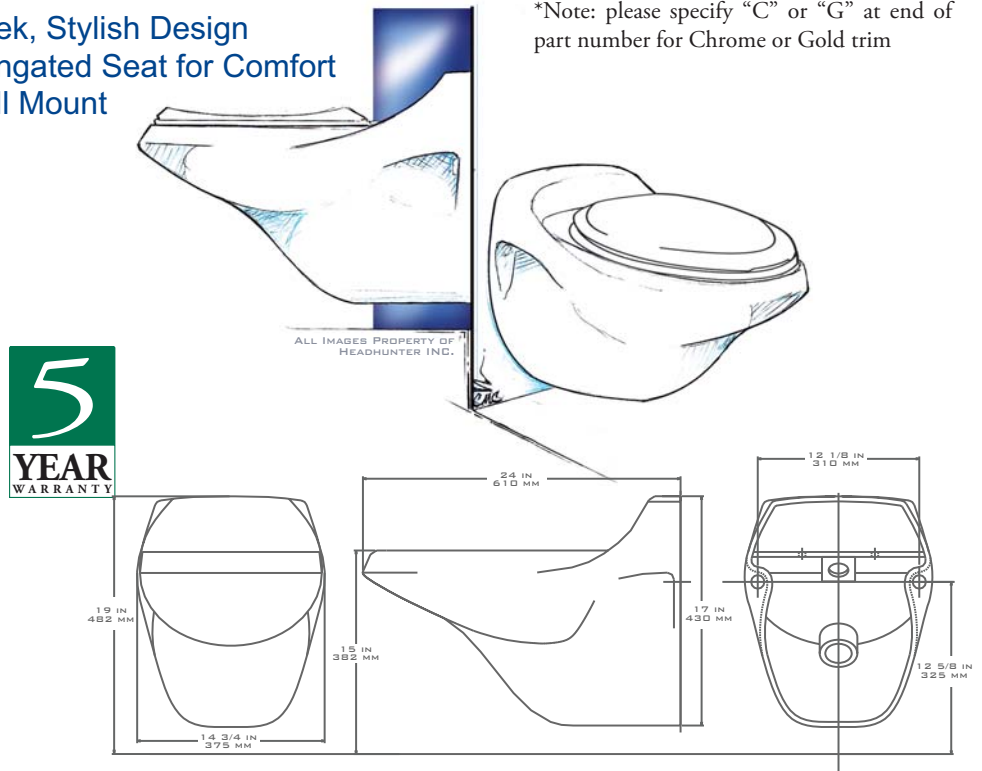

## The Wall Mounted Royal Flush Aero Bidet

Install an Aero Bidet to compliment your Royal Flush Aero toilet. With the same elegant styling, it's the perfect accessory for any luxury bathroom. The Aero bidet has the same dimensions as the Aero toilet and installation is a breeze with one our behind-the-wall mounting brackets. Designed to fit standard single penetration bidet fixtures, the Aero bidet is offered in the same four colors as all other Headhunter sanitary ware.

- AB-0\* White    AB-3\* Bone  
 AB-5\* Sand    AB-9\* Black

## Customer Satisfaction

Today's luxury yachts demand only the best in quality and reliability, which is why Headhunter's Royal Flush has become the industry standard. Many loyal customers have either specified Royal Flush as an upgrade when making their investment in a luxury yacht, or breathed a sigh of satisfaction when told by the builder that "Royal Flush is standard equipment." Headhunter nurtures this fierce customer loyalty with innovative products and excellent customer service. In fact, Headhunter is the only marine toilet manufacturer with its own field service team to provide O.E.M. technical support as well as retrofit installations.



# Commercial & Military Applications

The Royal Flush line of marine toilets are ideal for commercial and military applications because of their optimum water consumption effective odor control and simple installation. Utilizing pressurized water, jet maceration and small diameter discharge piping, the Royal Flush alternative saves weight, reduces installation labor, maintenance costs, and increases crew comfort.

- Small diameter discharge piping
- Reliable jet macerator operation
- Lightweight alternative to bulky vacuum collection systems
- Available in patented non-electric HydroVac systems
- Low volume flush reduces MSD size



## Royal Flush Commercial Superbowl & NeoClassic Stations

The Royal Flush Commercial Superbowl & NeoClassic Station includes an open front seat, vented loop, and mounting hardware. This model is ideal for commercial fishing and charter boats. Models for disabled persons are available on special request.

Inlet = 1 inch - 26mm flex hose

Outlet = Pipe size (1-1/2 inch I.D. 50mm O.D.), Hose size (1-7/8 inch I.D.)

|           |  |
|-----------|--|
| CSBS-0-M  | Commercial SBS w/Momentary Push Button Switch                |
| CSBS-0-TS | Commercial SBS w/Touch Switch                                |
| CNCS-0-M  | Commercial NeoClassic Station w/Momentary Push Button Switch |
| CNCS-0-TS | Commercial NeoClassic Station w/Touch Switch                 |

Commercial superbowl model featured in photo



## Royal Flush SBS-M Military Station

Headhunter customizes all Royal Flush stations for rugged military applications. Compared to conventional old vacuum toilets, the Royal Flush system provides a tremendous weight savings and drastic reduction in maintenance. Without vacuum pumps nor interface valves the Royal Flush system offers increased reliability with fewer moving parts. The water jet principle offers the added benefit of quieter operation. Units include black open front seats, shock absorbing mounting pad, electric bronze flush valves, or hydraulic bronze flush valves. Consult Headhunter for specific application specifications.

SBS-M Military Superbowl



Simple design, proven performance, and rugged reliability have made Royal Flush the ideal solution for the rigorous demands of the commercial market. Whether it's mini cruise ships, casino boats, dinner cruise vessels, high speed ferries, Alaskan commercial fishing boats, Naval Academy patrol vessels, Navy Cruisers, or even the latest jet-drive offshore crewboats bound for Nigeria; Royal Flush has been the dependable solution day after day, year after year.



# The Hydro-Vac Option



The patented Royal Flush Hydro-Vac utilizes the latest in marine toilet technology. A non-electric version of our Neoclassic and Superbowl, it's designed for use with central systems. The push button on the toilet opens the adder kit to initiate the flushing process. Inside there are no moving parts, no pumps, motors, no maintenance! Each toilet has a 5 year warranty, all colors match Kohler fixtures.



## FEATURES

- Non-electric
- One touch dry bowl feature
- Flushes rags, quarters, and panty hose.
- Lightest one-piece vitreous china toilet on the market
- Labor saving installation with quick connect inlet and discharge
- No complicated mechanical equipment in the discharge plumbing



### Size and Model of Bowl/Seat

- HVNC=19" Neoclassic with standard seat and cover
- HVCNC=19" Neoclassic with open front Comm. seat no cover
- HVSB= Superbowl with french curve seat
- HVCSB=Superbowl open front Comm. seat no cover

### Bowl Color

- 0=White
- 3=Bone (Kohler Biscuit)
- 5=Sand (Kohler Almond)
- 9=Black

### Push Button Finish

- C=Nickel/Chrome
- B=Polished Brass
- G=Gold

### Push Button Flush Actuator Position

- S=Side mount on toilet
- W=Wall mount

### Hydraulic Flush Valve/Inlet T Configuration

- A=Standard inlet T assembly (order hydraulic flush valve separately)
- B=Hydraulic flush valve integrated into toilet (Neoclassic only)

### Vented Loop Configuration

- 1=Standard vented loop kit (not pre-plumbed)
- 2=Integrated pre-plumbed vented loop (check valve supplied sep.)

*How to specify the Hydro-Vac model when ordering.*

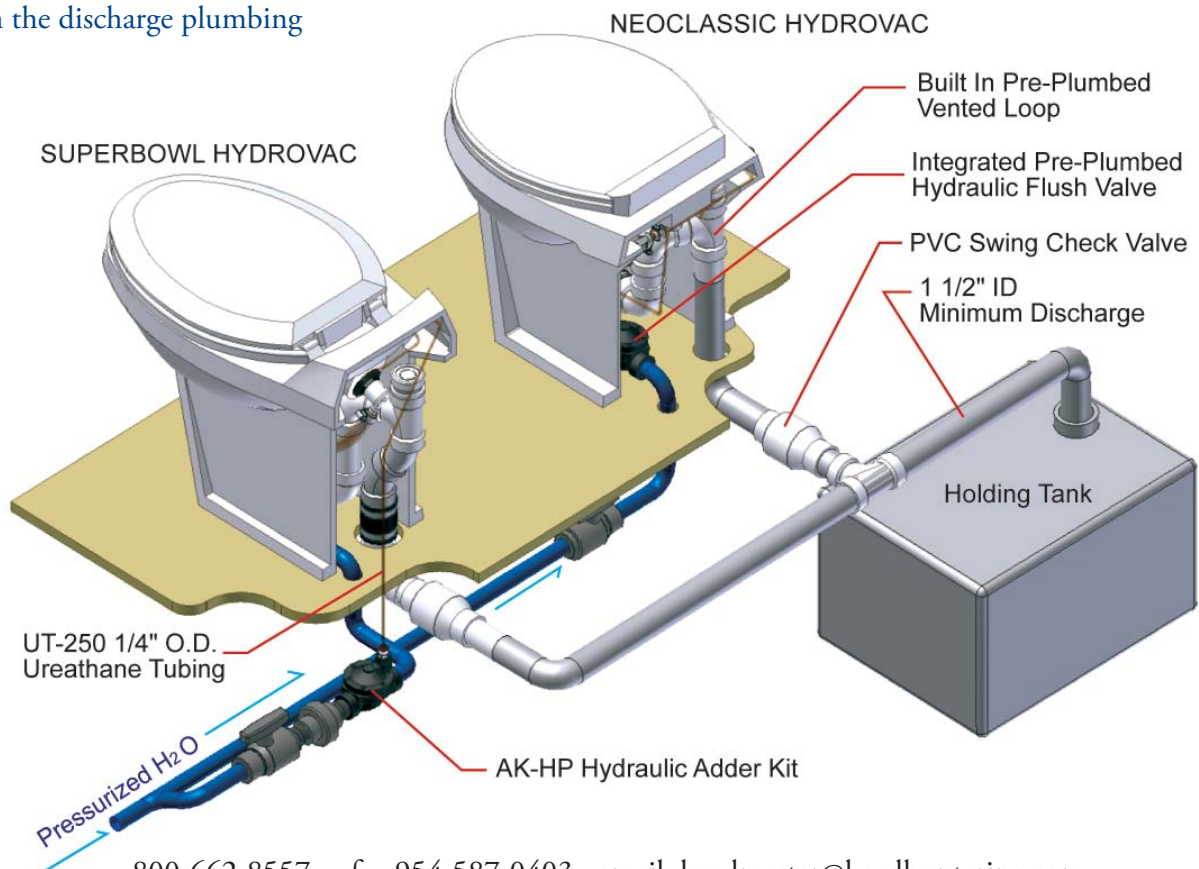

# The Central System Advantage

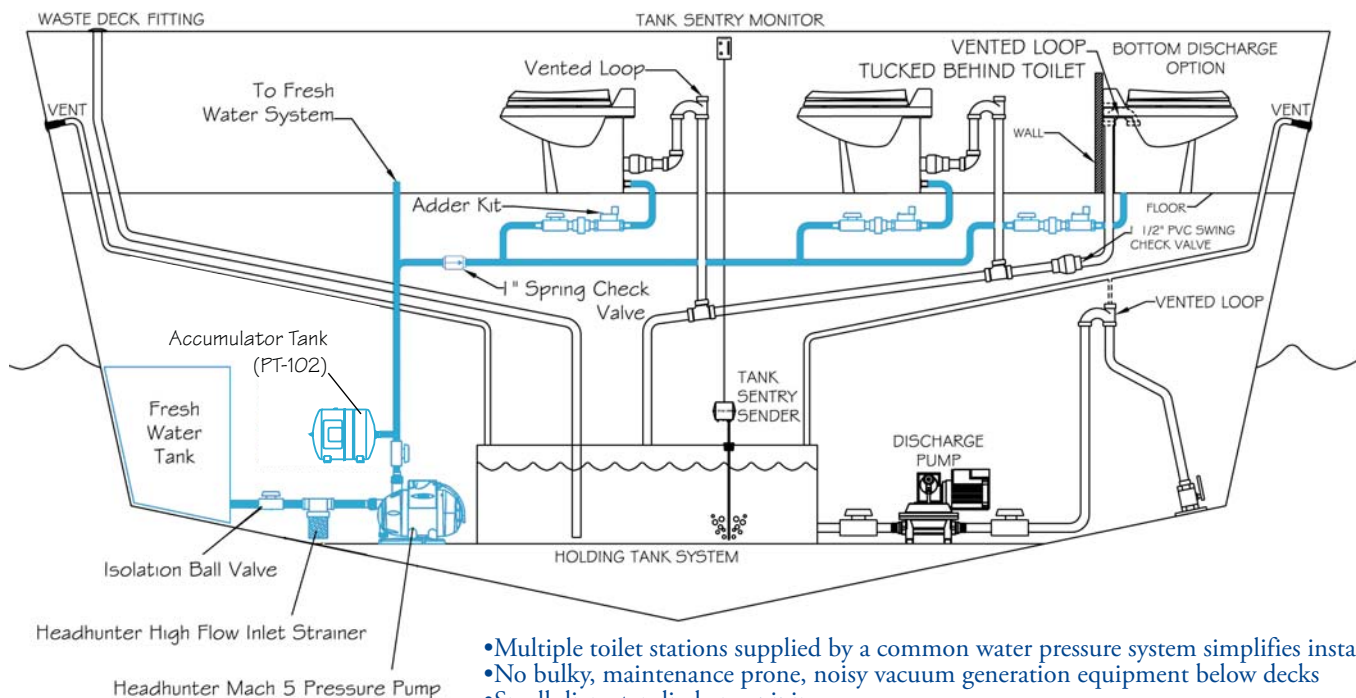

- Multiple toilet stations supplied by a common water pressure system simplifies installation
- No bulky, maintenance prone, noisy vacuum generation equipment below decks
- Small diameter discharge piping

A Royal Flush Central System is configured by supplying two or more Royal Flush stations with pressurized water from a central source. The water supply to each toilet in the system is controlled by a dedicated Adder Kit shown below (consisting of an isolation ball valve, a union, and an electric or nonelectric flush valve with self-cleaning inlet strainer). Activating the touch switch opens the flush valve, releasing pressurized water to the jet macerator.



AK-12 & 24



AK-HB



AK-HP



AK-HBS

## Headhunter Adder Kits

|            |   |
|------------|---|
| AK-12      | 12VDC/.35A Electric Flush Valve                         |
| AK-24      | 24VDC/.175A Electric Flush Valve                        |
| AK-12B     | 12VDC/.35A Electric Flush Valve, Brass Construction     |
| AK-24B     | 24VDC/.175A Electric Flush Valve, Brass Construction    |
| PS12V-W152 | Universal Pwr Supply, 100-240 VAC-12V DC 1.25A Output   |
| AK-HB      | Hydraulic (Nonelectric), Brass Construction             |
| AK-HBS     | Hydraulic (Nonelectric), Brass Construction, w/Strainer |
| AK-HP      | Hydraulic (Nonelectric)                                 |

## Single Station Systems

A Single Station System is ideal for boats with one or two toilets with a pump dedicated to each toilet. Activating the switch at the toilet turns the pump on, providing pressurized water.

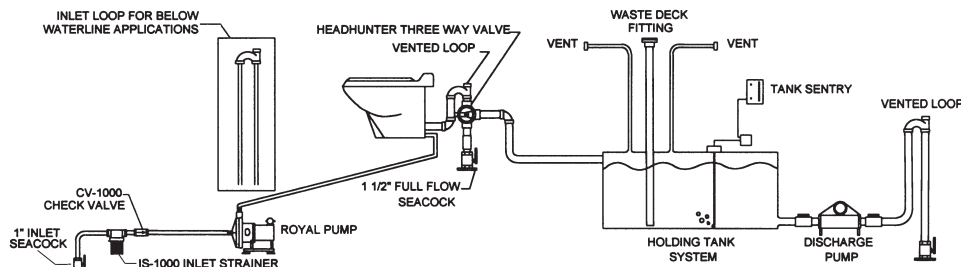

## Single Station Royal Pump

Designed specifically for single station-systems, these high pressure centrifugal pumps mount remotely in the engine room or under the sole. Flooded suction is necessary for proper operation. Use with 1" strainer and check valve. 1" ID flex hose connection.

|       |                                |
|-------|--------------------------------|
| RP-12 | Royal Pump 12V DC/60A          |
| RP-24 | Royal Pump 24V DC/30A          |
| RP-AC | Royal Pump 110/220V AC-15/7.5A |

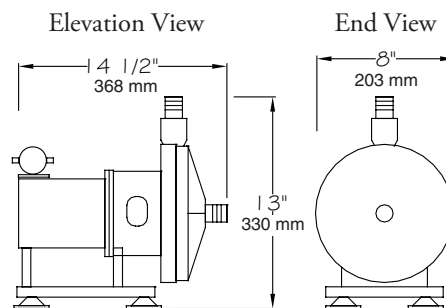

# Water Pressure Systems



## W A T E R P R E S S U R E S Y S T E M

### Break the sound barrier

The Mach 5 water pressure system from Headhunter represents a quantum leap in pump technology with many advanced features and improvements over conventional water pressure pumps. Integrated flow and pressure sensors provide instant dry run protection.



The Mach 5 incorporates a state-of-the-art multistage impeller system driven by a super-efficient water-cooled motor to generate up to 20 gallons per minute, instantaneously, on demand, and in virtual silence. An easy to read control panel on top of the pump provides visual indication of alarm status, as well as reset capability.

driven by a super-efficient water-cooled motor to generate up to 20 gallons per minute, instantaneously, on demand, and in virtual silence. An easy to read control panel on top of the pump provides visual indication of alarm status, as well as reset capability.



### SPECIFICATIONS

|                   |                 |
|-------------------|-----------------|
| Liquid Temp.      | 32°F To 104°F   |
| Ambient Temp.     | 32°F To 122°F   |
| Max Pressure      | 67 PSI (4.5bar) |
| Max Flow          | 20 GPM (76 lpm) |
| Suction/Discharge | 1" MPT (1"GAS)  |
| Noise Level       | <54 dB(A)       |
| Weight            | 23lbs (10.4kg)  |

### LISTING/CERTIFICATIONS

The Mach 5 has been tested and certified to surpass all requirements of Underwriters Laboratories UL 778 specifications for Motor Operated Pumps. The Mach 5 is CE approved.



Listing #01C01

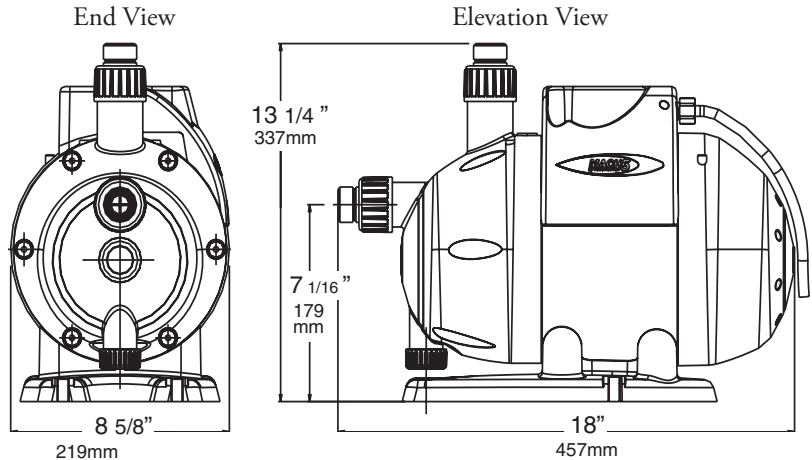

*Note: Not recommended for salt water*

### Feel the Force

Taking a great shower is one of life's simple pleasures. The performance and stamina of a Mach 5 Water Pressure System turns ordinary showers into a truly invigorating experience.



| Model             | Voltage   | Amps | Discharge Press. PSI (bar) |          |          | Max Shut Off PSI (bar) |
|-------------------|-----------|------|----------------------------|----------|----------|------------------------|
|                   |           |      | 30 (2)                     | 40 (2.7) | 50 (3.4) |                        |
| Flow in GPM (lpm) |           |      |                            |          |          |                        |
| M5-115            | 115V/60hz | 9    | 16 (60)                    | 12 (46)  | 8 (31)   | 67 (4.5)               |
| M5-230/60         | 230V/60hz | 4    | 16 (60)                    | 12 (46)  | 8 (31)   | 67 (4.5)               |
| M5-230/50         | 230V/50hz | 4    | 16 (60)                    | 12 (46)  | 8 (31)   | 67 (4.5)               |



# Water Pressure Systems



The Stingray Saltwater Pressure System is designed specifically for continuous duty in the harsh marine environment, and is the perfect solution for saltwater toilet flushing, live bait wells, aquaculture, and anywhere else high flow/pressure salt or fresh water is needed. Featuring an innovative multi-stage impeller system driven by a quiet TEFC motor, the Stingray is able to deliver over 20 GPM and up to 67 psi. The pre-installed Remora pump control turns the pump on when system pressure drops to 40 psi, and off when the pump reaches a no flow condition, allowing the Stingray to operate with or without a pressure accumulator tank as well as providing dry-run protection. An easy to view control panel with L.E.D. diagnostics and dry run visual alarm makes troubleshooting and system monitoring a breeze.



## SPECIFICATIONS

|                   |                         |
|-------------------|-------------------------|
| Liquid Temp.      | 32°F (0°C)-104°F (40°C) |
| Ambient Temp.     | 32°F (0°C)-122°F (50°C) |
| Max Pressure      | 67 PSI (4.5 bar)        |
| Max Flow          | 20 GPM (76 lpm)         |
| Suction/Discharge | 1" FPT/1" MPT (1" GAS)  |
| Weight            | 24lbs (10.9 kg)         |

*"The Stingray Saltwater Pressure System is an awesome solution for our deck washdown, and live baitwell needs. We especially like the simple no accumulator tank installation and amazing pressure it delivers!"*

*Paul Mann  
Mann Custom Boats  
Manns Harbor, N.C.*

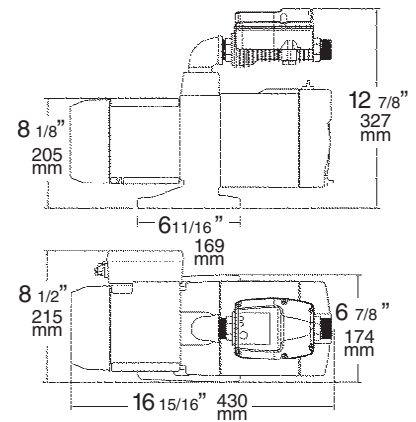

## LISTING/CERTIFICATIONS

The Stingray has been tested and certified to surpass all requirements of Underwriters Laboratories UL 778 specifications for Motor Operated Pumps. The Stingray is CE approved.



Listing #01C01

| Model     | Voltage   | Amps | Discharge Press. PSI (bar) |          |          | Max Shut Off PSI (bar) |
|-----------|-----------|------|----------------------------|----------|----------|------------------------|
|           |           |      | 30 (2)                     | 40 (2.7) | 50 (3.4) |                        |
|           |           |      | Flow in GPM (lpm)          |          |          |                        |
| SR-115    | 115V/60hz | 9    | 16 (60)                    | 12 (46)  | 8 (31)   | 67 (4.5)               |
| SR-230/60 | 230V/60hz | 4    | 16 (60)                    | 12 (46)  | 8 (31)   | 67 (4.5)               |
| SR-230/50 | 230V/50hz | 4    | 16 (60)                    | 12 (46)  | 8 (31)   | 67 (4.5)               |



photo courtesy of Hatteras Yachts



## SubpaQ Water Pressure Systems



- Super quiet
- Built in dry run protection
- Innovative concept saves machinery space
- Constant pressure variable speed operation

*Run silent ...run deep* is the mission for the SubpaQ Water Pressure System from Headhunter. Unlike conventional water pumps, the SubpaQ installs inside the freshwater tank, saving precious space in the machinery room, and eliminating priming difficulties. This variable speed, constant-pressure pump provides flow rates that out-perform conventional pumps with similar power consumption. Let sleeping crews lie! The SubpaQ's innovative motor technology and submerged location result in incredibly silent operation.

Manufactured with 300 series stainless steel and tungsten carbide bearings, the SubpaQ is tough enough for the most demanding applications. Reliability is further enhanced with built-in functionality for protection against running dry and over-or under-voltage. The SubpaQ Water Pressure system is an ideal solution for the high flow and pressure demands of today's luxury yachts, and commercial/military vessels.



Pump settings and historical pump operating data can be accessed from the control panel with the hand held remote. Data and pump settings can be printed out to an optional HP printer available from Headhunter.

Panel dimensions:  
9"(229mm) L x 6-1/4"(159mm) H x 3-3/4"(96mm) D

## IN-TANK<sup>mount</sup>

SPQ In-Tank SubpaQ System

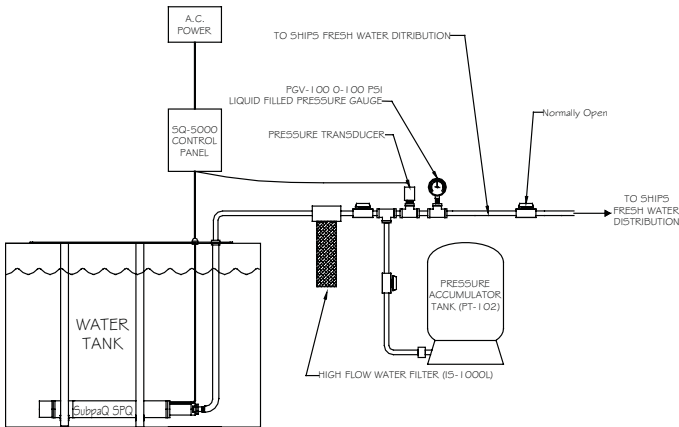

All in-tank SubpaQ systems include pump with stainless mounting bracket and flow sleeve, stainless pressure transducer and SQ-5000 control panel. Consult Headhunter for custom hatch and mounting bracket fabrication.

| Dimensions: | Length         | Width         | Height        |
|-------------|----------------|---------------|---------------|
| SPQ 2273    | 35-3/4"(908mm) | 7-1/8"(181mm) | 5-1/2"(140mm) |
| SPQ 3385    | 37-1/2"(953mm) | 7-1/8"(181mm) | 5-1/2"(140mm) |

Dry Wt. 23 lbs.

| Model        | Voltage            | hp  | Amps | Discharge Size | Discharge Press. PSI (bar) |          |         | MaxShut Off PSI (bar) |
|--------------|--------------------|-----|------|----------------|----------------------------|----------|---------|-----------------------|
|              |                    |     |      |                | 40 (2.7)                   | 50 (3.4) | 60 (4)  |                       |
| SPQ-2273-230 | 200-240V, 50/60 hz | 1/2 | 4.9  | 1 1/2" FPT     | 24 (91)                    | 18 (70)  | 17 (65) | 73 (5)                |
| SPQ-3385-230 | 200-240V, 50/60 hz | 1   | 7.6  | 1 1/2" FPT     | 33 (127)                   | 28 (108) | 21 (79) | 85 (5.8)              |

## EXTERNAL<sup>mount</sup>

SPX External Tank SubpaQ System



All external SubpaQ systems include pump installed in stainless pipe sleeve, SQ-5000 control panel, and stainless pressure transducer. 1" FPT inlet/outlet

Dimensions: 43-11/16"(1109mm) L 4-9/16"(156mm) Dia  
Dry Wt. 25 lbs.

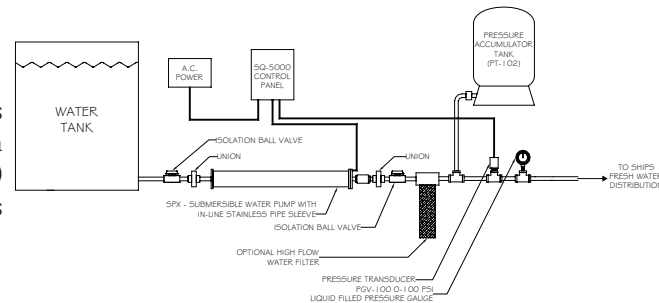

| Model        | Voltage            | hp  | Amps | Discharge Size | Discharge Press. PSI (bar) |          |         | MaxShut Off PSI (bar) |
|--------------|--------------------|-----|------|----------------|----------------------------|----------|---------|-----------------------|
|              |                    |     |      |                | 40 (2.7)                   | 50 (3.4) | 60 (4)  |                       |
| SPX-2273-230 | 200-240V, 50/60 hz | 1/2 | 4.9  | 1 1/2" FPT     | 24 (91)                    | 18 (70)  | 17 (65) | 73 (5)                |
| SPX-3385-230 | 200-240V, 50/60 h  | 1   | 7.6  | 1 1/2" FPT     | 33 (127)                   | 28 (108) | 21 (79) | 85 (5.8)              |

# Water Pressure Systems



HydropaQ water pressure systems engineered and fabricated exclusively by Headhunter are the ideal solutions for demanding commercial and military applications where ease of installation, operation, and reliability are essential. The skid mounted, pre-wired systems provide a turn-key package in a lightweight and compact configuration. Systems can be set up by Headhunter engineers to provide entire plants, ships, yachts, or buildings with the water pressure needed to operate.

## FEATURES

- Quiet operation
- Dry run protection
- Flow rates from 0-400 gpm
- Pressure ranges up to 250 psi
- Skid mounting for easy installation
- Pump horsepower ranges from 1-20 hp
- Efficient vertical multistage design
- Variable speed motor controls for constant pressure
- Pumps constructed of cast iron, with stainless steel 316 manifolds
- Compact package utilizes less floor space than conventional systems
- Eliminates large expensive tanks
- Variable speed motor controls for constant pressure

## OPTIONS

- Custom controls in various languages
- All titanium or all 316 construction for salt water applications
- Built-in priming pump for suction lift applications

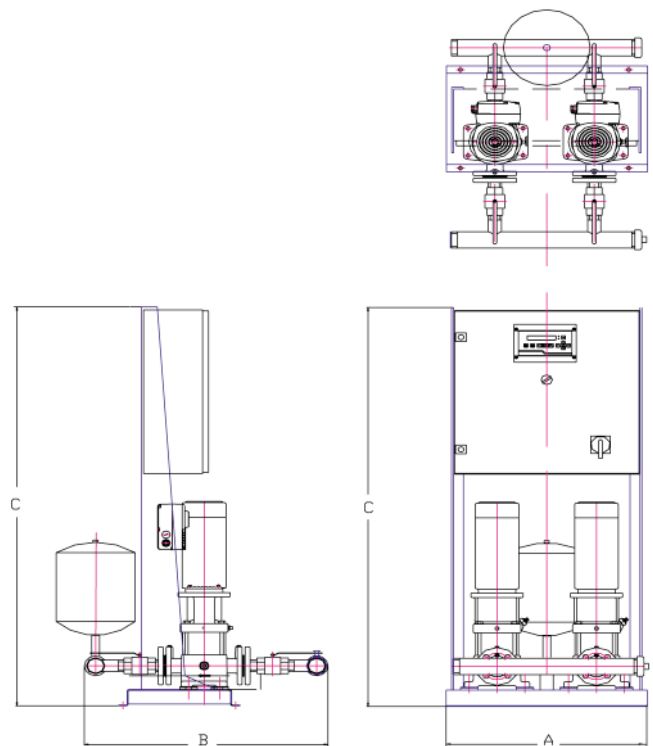
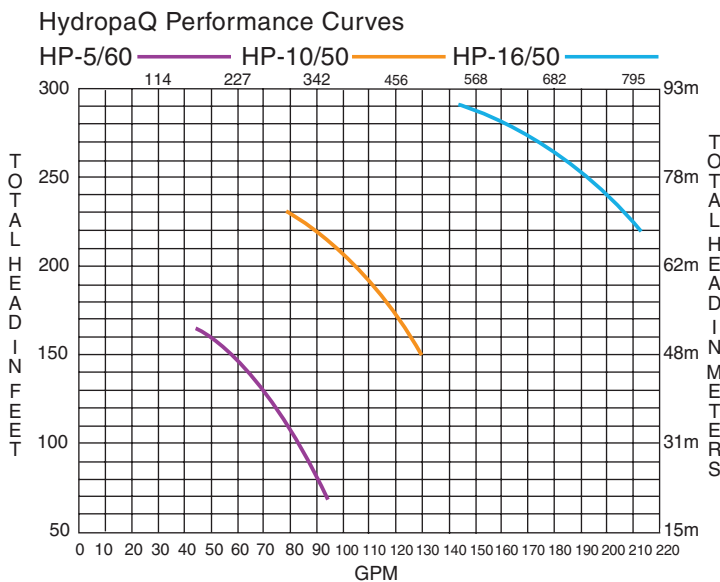

| Model Number | A (mm)    | B (mm)    | C (mm)    | Weight (kg)   | V/A                  | V/A                | V/A                 |
|--------------|-----------|-----------|-----------|---------------|----------------------|--------------------|---------------------|
| HP-5/60      | 23"(584)  | 26"(660)  | 58"(1473) | 585 lbs (265) | 208V, 3Ø / 12.2 amps | 230V, 1Ø / 22 amps | 460V, 3Ø / 6.1 amps |
| HP-10/50     | 50"(1270) | 36"(914)  | 45"(1143) | 833 lbs (378) | 208V, 3Ø / 32 amps   | N/A                | 460V, 3Ø / 16 amps  |
| HP-16/50     | 52"(1320) | 45"(1143) | 48"(1219) | 962 lbs (436) | N/A                  | N/A                | 460V, 3Ø / 30 amps  |

# 12-24VDC Water Pump



## 12-24 VDC WATER PRESSURE SYSTEM

PATENTED

### INTEGRATED CERAMIC PRESSURE TRANSDUCER:

Monitors system pressure and controls the speed of the X-Caliber. High linearity, accuracy, and excellent chemical resistance are hallmarks of the ceramic pressure sensor technology found exclusively in the X-Caliber.

### BRUSHLESS WATER COOLED MOTOR:

Brushless motor technology is quieter and more reliable than standard DC motor technology. Silence and efficiency of the motor is further enhanced by an advanced water cooling system.

### WHISPER QUIET MULTISTAGE IMPELLERS

Deliver smooth pulsation free water pressure in virtual silence.

### CORROSION PROOF UL94HB GLASS REINFORCED POLYPROPYLENE CONSTRUCTION:

This specially formulated composite polymer is designed to withstand the harsh marine environment.



| Part #  | Description                                    |
|---------|--|
| XR-124  | X-Caliber 12-24 VDC Freshwater Pressure System |
| XRS-124 | X-Caliber 12-24 VDC Saltwater Pressure System  |

Blast into the future with the advanced technology of the new X-Caliber DC water pressure system. The stealthy X-Caliber delivers high performance water pressure that will invigorate showers, and dramatically improve overall water pressure system capability.

### CONTROL PANEL



Program power and pressure settings via the integrated control panel. Four colored LED's display current settings and alarm conditions.

### ADVANCED FEATURES

- Adjustable cut in pressure
- Operates on 12 or 24VDC
- Under voltage protection
- Anti-flooding protection
- Variable Speed
- Adjustable power setting
- Over voltage protection
- Over current protection
- Dry run protection
- Rotating bracket

### INNOVATIVE ROTATING BRACKET

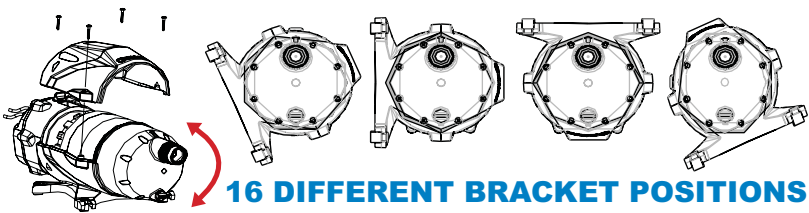

16 DIFFERENT BRACKET POSITIONS

### SPECIFICATIONS

|                   |                                    |
|-------------------|------------------------------------|
| Liquid Temp.      | 32°F (0°C)-104°F (40°C)            |
| Ambient Temp.     | 32°F (0°C)-122°F (50°C)            |
| Max Pressure      | 67 PSI (4.5 bar)                   |
| Max Flow          | 10 GPM (38 lpm)                    |
| Suction/Discharge | 3/4" FPT (Optional metric adapter) |
| Weight            | 16lbs (7.2 kg)                     |

### PERFORMANCE CURVE

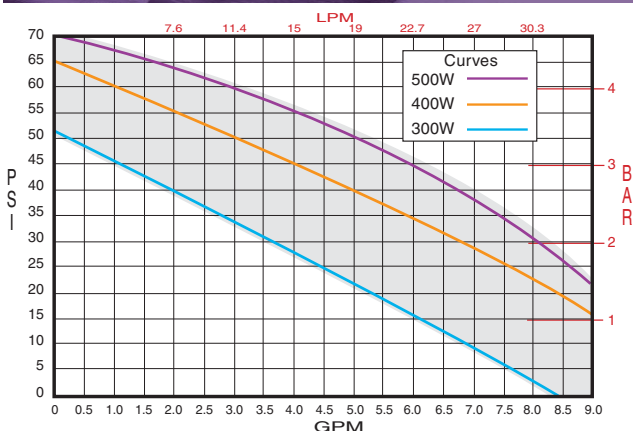

| Power Setting | Voltage/Amps |        |
|---------------|--------------|--------|
|               | 12 VDC       | 24 VDC |
| 300W          | 25 A         | 12.5 A |
| 400W          | 34 A         | 17 A   |
| 500W          | 42 A         | 21 A   |

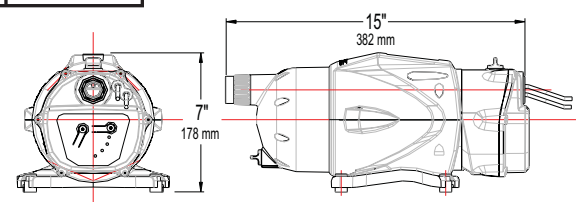
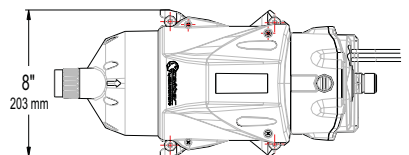

# Water Pressure Accessories

## Inlet Strainers

Pump inlet strainers are an important component in a well designed water pressure system, since they protect the pump and ship systems from potentially fatal debris. Both the Headhunter IS-1000L and IS-1000S are perfect solutions for an inlet strainer since they have the unique combination of a fine mesh, with hi-flow characteristics, which provide maximum protection with minimum flow restrictions.

The IS -1000L is constructed of white glass reinforced polypropylene with molded-in 1" FPT brass inlet and discharge fittings. Also included but not shown is a white powder coated mounting bracket.



IS-1000L



IS-1000S  
IS-750

|           |  |   |
|-----------|--|---|
| IS-1000L  | 1" Female NPT High Flow Composite Strainer | 5" L x 4" W x 6-7/8" H<br>127mm L x 102mm W x 175mm H |
| IS-1000LB | 1" Female BSP High Flow Composite Strainer | 5" L x 4" W x 6-7/8" H<br>127mm L x 102mm W x 175mm H |
| ISB-1000L | Replacement Strainer Basket                |   |

IS-1000S is a all nylon compact solution for areas where space is limited.

|               |  |  |
|---------------|--|--|
| IS-1000S      | 1" Female NPT Compact High Flow Inlet Strainer   | 4" L x 3" W x 5-3/4" H<br>101mm L x 76mm W x 146mm H |
| IS-750        | 3/4" Female NPT Compact High Flow Inlet Strainer | 4" L x 3" W x 5-3/4" H<br>101mm L x 76mm W x 146mm H |
| ISB-750/1000S | Replacement Strainer Basket                      |  |



PGV-100



PGH-100

## Stainless Steel Pressure Gauges

Headhunter glycerin filled stainless steel pressure gauges provide reliable and accurate pressure monitoring. A quality gauge is important for proper installation and trouble shooting of all water pressure systems. Available in vertical and horizontal mount with 1/4" MPT connection.

|         |  |
|---------|--|
| PGV-100 | 0-100 PSI Liquid Filled Pressure Gauge (vert. mt) MPT Bottom Conn. |
| PGH-100 | 0-100 PSI Liquid Filled Pressure Gauge (horz. mt) MPT Back Conn.   |

## High Flow Water Filters

High Flow Water Filters keep your fresh water free of odors and contaminants. These filters are designed to handle the delivery capacities of our Headhunter water pressure systems. They are available in 304 or 316 stainless steel construction with either flanged or NPT pipe connections. The supplied unique high-performance extruded carbon cartridges are optimized for applications where they replace both the sediment and activated carbon filters. The cartridges also insure that there won't be any carbon particulates in the water system as is common with granular activated carbon filters.



|           |  |                    |
|-----------|--|--------------------|
| HFF-1*    | 6 GPM High Flow Charcoal Water Filter      | 4-1/8"D x 13-3/4"H |
| HFF-4*    | 8 GPM High Flow Charcoal Water Filter      | 10-1/2"D x 20"H    |
| HFF-7*    | 20 GPM High Flow Charcoal Water Filter     | 12-1/2"D x 20"H    |
| HFF-SCB10 | 10" High Flow CarbonBlock Filter Cartridge |                    |

\* Specify 304L or 316L Stainless Steel at the end of part number when ordering  
Consult Headhunter for high flow rates

## Ultraviolet Sterilizers

These high quality Ultraviolet Sterilizers offer a simple approach to disinfection of potable water on board. They feature 316 stainless steel construction and come in a variety of sizes to match the delivery capacity of your Headhunter water pressure system. All sterilizers also incorporate a wiper mechanism to clean the quartz sleeve without interrupting operation. The easy change bulb system enables effortless lamp replacement without shut-down of water pressure or drainage of tank.

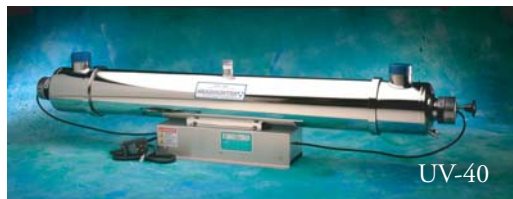

UV-40

|       |                            |                                   |          |
|-------|----------------------------|-----------------------------------|----------|
| UV-6  | 6 GPM UV Water Sterilizer  | 25-3/8" L x 5-1/2" W x 8-1/4" H   | 14 lbs.  |
| UV-12 | 12 GPM UV Water Sterilizer | 39-1/2" L x 5-1/2" W x 9-1/2" H   | 30 lbs.  |
| UV-20 | 20 GPM UV Water Sterilizer | 52-1/2" L x 5-1/2" W x 9-1/2" H   | 36 lbs.  |
| UV-40 | 40 GPM UV Water Sterilizer | 52-1/8" L x 5-1/2" W x 11-1/2" H  | 49 lbs.  |
| UV-83 | 83 GPM UV Water Sterilizer | 52-1/8" L x 17-1/4" W x 11-1/2" H | 116 lbs. |

# Water Pressure Systems

## Polypropylene Lined Steel Pressure Accumulator Tanks



This compact 4.4-gallon pressure tank is designed for operation in seawater or freshwater. It's constructed from deep drawn steel with a polypropylene liner, seamless butyl diaphragm and brass threaded connection. The exterior is undercoated with a crack-proof zinc based barrier coating that is top coated with white enamel. Available pump bracket that matches X-caliber mounting pattern. 11" D x 11 1/2"H x 15"L Inlet 3/4" male NPT

- Polypropylene liner forms non-metallic water reservoir
- Corrosion resistant brass male threaded connection
- Heavy-duty seamless butyl diaphragm flexes, never stretches or creases
- Meets FDA requirements for potable water supply
- Crack proof, impermeable, self-repairing zinc based corrosion barrier with white enamel topcoat protects the exterior.

| Model    | Drawdown in gallons (liters) |                           |                         | Dimensions in inches (mm) |          |             | Total Volume in Gal. (ltr) | Inlet Fitting (MPT) | Dry Weight lbs (kg) |
|----------|------------------------------|---------------------------|-------------------------|---------------------------|----------|-------------|----------------------------|---------------------|---------------------|
|          | @ 20-40 psi (2.0-3.4 bar)    | @ 30-50 psi (2.0-3.4 bar) | @ 40-60 psi (2.7-4 bar) | Length A                  | Diameter | Height B    |                            |                     |                     |
| PT-102   | 1.6(6)                       | 1.4(5.2)                  | 1.2(4.5)                | 15(381)                   | 11(279)  | 11(279)     | 4.4(16.7)                  | 3/4                 | 9(4.1)              |
| PT-102BK | 1.6(6)                       | 1.4(5.2)                  | 1.2(4.5)                | 15(381)                   | 11(279)  | 11 3/4(298) | 4.4(16.7)                  | 3/4                 | 9(4.1)              |



Certified to ANSI/NSF STD61

\*PT-102BK includes bracket



Also available from Headhunter, Well-X-Trol pressure accumulator tanks. They are easy to install, hand can be installed either vertically or horizontally. Models are also available with pump brackets and mounting feet.

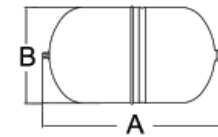

| Model     | Drawdown in gallons (liters) |                         | Total Volume in Gal. (ltr) | Dimensions in inches (mm) |              |          | Inlet Fitting (MPT) | Dry Weight lbs (kg) |
|-----------|------------------------------|-------------------------|----------------------------|---------------------------|--------------|----------|---------------------|---------------------|
|           | @ 30-50 psi (2.0-3.4 bar)    | @ 40-60 psi (2.7-4 bar) |                            | Length A                  | Diameter     | Height B |                     |                     |
| WX-101    | .6 (2.2)                     | .5 (1.5)                | 2 (7.6)                    | 12 5/8 (321)              | 8 (203)      | 8 (203)  | 3/4"                | 5 (2.26)            |
| WX-200-PS | 4.3 (16)                     | 3.8 (14.4)              | 14 (53)                    | 16 (406)                  | 15 3/8 (391) | 16 (406) | 1"                  | 29 (13.4)           |
| ST-25*    | 3.5 (13)                     | 2.7 (10)                | 10 (39)                    |                           | 15 3/8 (391) | 19 1/4   | 1"                  | 23 (10.4)           |

\*Note: ST-25 suitable for saltwater use.

## Fiberglass Pressure Accumulator Tanks



Specify Headhunter pressure accumulator tanks for fresh or saltwater pressure systems to store pressurized water. They eliminate water hammer and reduce pump cycling. These accumulator tanks are also used in our Royal Flush Central Systems for storing pressurized water for toilet flushing. These tanks lead the field with a unique composite construction. Two miles of epoxy-coated fiberglass filament are wound around a high-density polyethylene liner, providing light weight, corrosion-resistant strength.

- Lightweight design-weighs half as much as conventional steel tanks
- Zero maintenance-unlike steel tanks, no need to paint
- Will not rust-no metallic components
- 5 year warranty
- Replaceable inner liner
- ANSI/NSF STB61 certified

| Model  | Drawdown in gallons (liters) |                         | Dimensions in inches (mm) |              | System connection (PVC) | Dry Weight lbs (kg) |
|--------|------------------------------|-------------------------|---------------------------|--------------|-------------------------|---------------------|
|        | @ 30-50 psi (2.0-3.4 bar)    | @ 40-60 psi (2.7-4 bar) | Height                    | Diameter     |                         |                     |
| AVF-4  | 4.3 (17)                     | 3.7 (14)                | 26 1/2 (673)              | 16 (406)     | 1" MPT                  | 15 (6.8)            |
| AVF-6  | 5.9 (23)                     | 5.1 (20)                | 32 1/4 (820)              | 16 (406)     | 1" MPT                  | 19 (8.6)            |
| AVF-9  | 8.9 (34)                     | 7.7 (30)                | 44 (1118)                 | 16 (406)     | 1" MPT                  | 24 (11)             |
| AVF-12 | 12.1 (46)                    | 10.5 (40)               | 56 3/4 (1442)             | 16 (406)     | 1" MPT                  | 30 (13.6)           |
| AVF-18 | 18 (69)                      | 16 (62)                 | 42 1/4 (1073)             | 24 (610)     | 1 1/4" MPT              | 50 (22.7)           |
| AVF-26 | 26 (100)                     | 23 (88)                 | 55 1/2 (1410)             | 24 1/4 (616) | 1 1/4" MPT              | 58 (26.3)           |
| AVF-36 | 36 (139)                     | 31 (120)                | 74 1/4 (1892)             | 24 1/2 (622) | 1 1/4" MPT              | 112 (50.8)          |



Certified to ANSI/NSF STD61

# Water & Waste Hoses

## **BANZAI PIPELINE** POTABLE WATER SUCTION/PRESSURE HOSE



### Applications

- Water Pump Suction and Pressure Distribution
- Freshwater Tank Vents
- Reverse Osmosis Low Pressure Supply

### Features

- Exceeds the specification of NSF 61 drinking water system components
- Steel helix reinforcement prevents collapsing and kinking
- Polyester braid reinforcement enables high working pressure
- One hose suitable for both suction and pressure applications
- Clear see through construction provides visual flow indication

| No.     | I.D.      | Working Pressure | Bending Radius | Coil Length      |
|---------|-----------|------------------|----------------|------------------|
| BPH-750 | ¾" (19mm) | 225psi (15 Bar)  | 2" (50mm)      | 100 ft. (30.5mt) |
| BPH-100 | 1" (25mm) | 225psi (15 Bar)  | 3" (75mm)      | 100 ft. (30.5mt) |

Banzai Pipeline is the only fresh water hose that combines three unique properties. A steel helix for collapsing resistance is combined with a hi-tensile woven polyester braid between two layers of clear PVC. The result is an engineered drinking water approved hose that's perfect for high pressure distribution and suction side applications. Banzai Pipeline features superior strength and non-collapsible flexibility not found in conventional water hoses. The clear see through construction provides visual flow indication which helps in the installation and maintenance of water pressure systems. Temp. Range 30 – 145 F (0 – 63 degree C)

## **GREAT WHITE** SUPER PREMIUM WATER/SANITATION HOSE



### Applications

- Black Water Discharge & Transfer • Toilet Pressure Supply • Holding Tank Vents • Freshwater Tank Vents • Freshwater Suction and Pressure Distribution • Gray Water Drains • Gray Water Tank Vents

### Features

- Super Flexible Construction
- Superior Odor Impermeability.
- Exceeds the specification of NSF 61 drinking water system components
- Max Temperature: 200F (94C). Will not degrade in high temperature engine room environments.
- EPDM Shell: Provides superior Ozone resistant external liner
- BUTYL Shell: Provides a smooth anti-microbial food grade inner liner.

Headhunter Great White™ Super Premium Water/Sanitation Hose is an engineered hose developed especially for the rigors of the harsh marine environment. A specially formulated liner constructed of anti-microbial food quality butyl polymer provides an impermeable odor barrier. A double steel wire helix and high tensile fabric reinforcement provide extreme flexibility for ease of installation and a snow white EPDM abrasion resistant jacket provide superior Ozone resistance not found in conventional sanitation hoses.

| No.      | I.D.          | Working Pressure | Bending Radius | Coil Length       |
|----------|---------------|------------------|----------------|-------------------|
| GWH-750  | ¾" (19mm)     | 100psi (7 Bar)   | 2" (50mm)      | 100 ft. (30.48mt) |
| GWH-1000 | 1" (25mm)     | 100psi (7 Bar)   | 3" (75mm)      | 100 ft. (30.48mt) |
| GWH-1500 | 1½" (38mm)    | 100psi (7 Bar)   | 3 1/2" (90mm)  | 50 ft. (15.24mt)  |
| GWH-1780 | 1 7/8" (48mm) | 100psi (7 Bar)   | 5 1/4" (134mm) | 50 ft. (15.24mt)  |
| GWH-2000 | 2" (51mm)     | 100psi (7 Bar)   | 6" (153mm)     | 50 ft. (15.24mt)  |

# Waste Water Systems



diaphragm pump

- Quiet diaphragm operation
- Able to pass large solids
- Can run dry without damage
- 12 foot suction lift capability
- 2" inlet and discharge standard
- 10 foot discharge head
- TEFC Motor

These pumps are the ultimate sewage handling pumps. They get the tough jobs done quickly, quietly, and reliably. Ideal for holding tank discharge applications, transfer systems, and for batching sewage into our Tidal Wave Type II MSD's. These pumps are an engineer's dream with their rugged construction and non-clogging flow-thru design. They make a great emergency bilge pump and are also ideal for industrial applications such as ground water remediation, abrasive fluid transfers, and dewatering.

## SPECIFICATIONS

Electric motor (12/24V DC, 115 / 208 - 230V AC), or air powered. Other electric motor voltages available, just ask. Standard bronze construction, aluminum available by special order. Viton diaphragm available for oil or fuel pumping applications.

| Model            | Flow Rate GPM (lpm) | Voltage               | Amps    | Discharge Size | Construction   |
|------------------|---------------------|-----------------------|---------|----------------|----------------|
| Electric Powered |                     |                       |         |                |                |
| 120ELB20AC200    | 20 (76)             | 115/208-230V AC       | 7.4/3.8 | 2"             | Bronze/Hypalon |
| 120ELB2012200    | 20 (76)             | 12VDC                 | 50      | 2"             | Bronze/Hypalon |
| 120ELB2024200    | 20 (76)             | 24VDC                 | 25      | 2"             | Bronze/Hypalon |
| Air Powered      |                     |                       |         |                |                |
| 120ACB20200      | 20 (76)             | 8 CFM@85psi (5.8 bar) |         | 2"             | Bronze/Hypalon |

Please call us for additional options, such as Aluminum construction, Viton diaphragm, or different motor voltages.

See page 18 for Clear PVC Check Valves, recommended for suction and discharge piping.

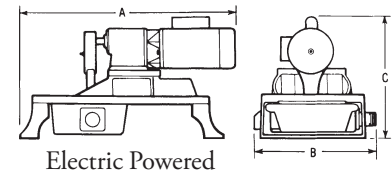
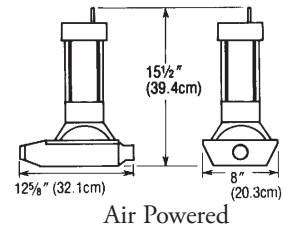

- A.Length 30-3/4" (78.1 cm)
- B.Width 17" (43.2 cm)
- C.Height 16-1/2" (41.9 cm)
- D.Weight 112 lbs (51 kg)

## REPAIR KIT

Part Number  
114N117120

Description  
Bone Dry Hypalon Repair Kit

Repair kits consist of a replacement diaphragm, two valve assemblies, and two sealing washers.

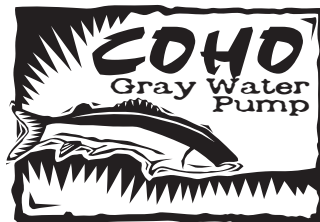

- Quick & easy gray water transfer solution
- High flow and discharge head capacity
- Quiet operation
- TENV Motor

The Coho provides an easy and compact solution for movement of gray water onboard. It's a combined receiving tank, discharge pump, and motor controller all in one. Just bolt it in and hook up the pipes.  
Weight: 27 lbs.

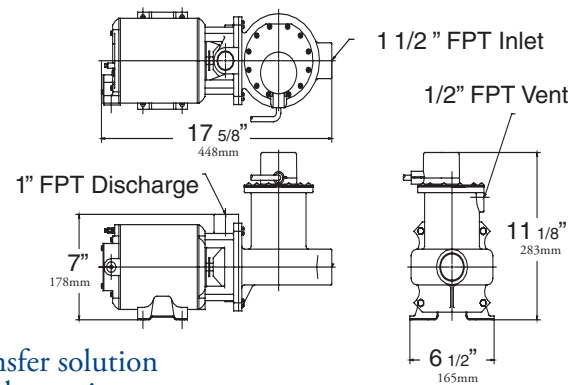

| Model             | Voltage           | Amps  | Discharge Head ft (m) |          |          |
|-------------------|-------------------|-------|-----------------------|----------|----------|
|                   |                   |       | 5 (1.5)               | 10 (3.0) | 15 (4.6) |
| Flow in GPM (lpm) |                   |       |                       |          |          |
| COHO-AC           | 115V/230V 50/60hz | 7/3.5 | 31 (117)              | 25 (95)  | 18 (68)  |

Note: Flow rates at 60 hz operation





## Super Quiet Operation



The Mako 1 is an aggressive solids handling diaphragm pump constructed of a lightweight corrosion resistant aluminum alloy. This pump is ideal for sewage, gray water, and bilge applications on vessels where space is a premium. Its' solids handling and self-priming properties make it ideal for transferring waste from holding tanks into our sewage treatment systems. All pumps are equipped with 1-1/2 inch hose bars for fast, easy installation.

**FAST  
RUGGED**

9 US GPM/ 34 LPM

**AGGRESSIVE  
LIGHTWEIGHT  
SELF PRIMING**

Neoprene diaphragm & valves, aluminum alloy pump body

Passes up to 1/2" (13mm) solids

45 lbs (20 kg)

Lifts up to 9' (2.7m), discharge to 15' (4.5m)

**EASY INSTALLATION**

1-1/2" ID hose attachments in & out of pump

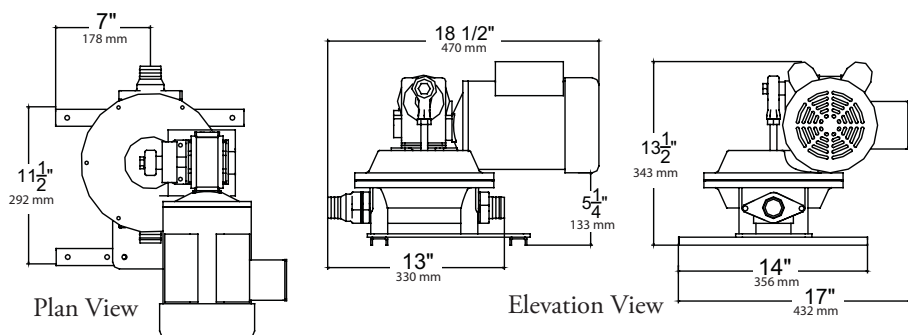

| Model  | Voltage   | Amps | Breaker Size Amps |
|--------|-----------|------|-------------------|
| M1-12  | 12VDC     | 24   | 45                |
| M1-24  | 24VDC     | 12   | 25                |
| M1-115 | 115V/60hz | 6.5  | 10                |
| M1-230 | 230V/60hz | 3.2  | 5                 |

*Other electric motor voltages available, just ask.*

See page 18 for Clear PVC Check Valves, recommended for suction and discharge piping.



Perfect for applications involving holding tanks, gray water tanks, or discharge from sewage treatment systems, the Barracuda is designed to thrash through wastewater.

The marine bronze pump body and impeller slurries waste, passes large solids, and runs dry without damage. The 316 stainless steel shaft and mechanical seal provides years of dry, trouble free service.

- Passes solids up to 1-1/4" diameter
- Bronze pump body & impeller, 316 SS pump shaft & seal
- 2" FPT connections
- Max discharge of 30' (9m)
- Max flow of 50 GPM (190 lpm)
- Requires flooded suction
- 40 lbs (18 kg)
- Dry run capability
- TEFC motor

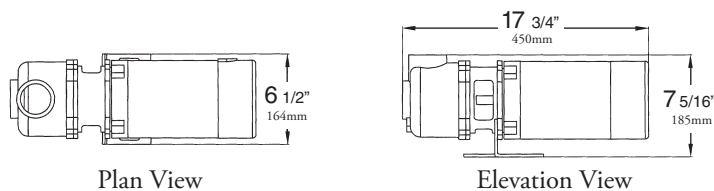

| Model   | Voltage          | Amps    | Discharge Head ft (m) |          |          |
|---------|------------------|---------|-----------------------|----------|----------|
|         |                  |         | 10 (3)                | 15 (4.6) | 25 (7.6) |
| BSTR-AC | 115/230V 60hz    | 9.6/4.8 | 48 (182)              | 30 (114) | 12 (45)  |
| BSTR-12 | 12VDC            | 57      | 48 (182)              | 30 (114) | 12 (45)  |
| BSTR-24 | 24VDC            | 29      | 48 (182)              | 30 (114) | 12 (45)  |
| BSTR-3P | 208-230/440 60hz | 3.2/1.6 | 48 (182)              | 30 (114) | 12 (45)  |

# Waste Water Accessories



## Three Way Valve

This heavy duty valve is constructed of schedule 80 CPVC. It accepts 1-1/2" or 2" PVC pipe, or 1-7/8", and 1-1/2" hose (fittings included). Valve is full flow with no restrictive bends or constrictions. Handle may be locked or removed to meet U.S Coast Guard requirements for securing the system. Includes removable mounting feet shown.  
6-1/2" (165mm) L x 7-1/8" (181mm)W x 6-1/2" (165mm) H

TW-1515

Headhunter Universal Three Way Valve w/Mounting Hardware



## Swing Check Valves

Headhunter clear PVC swing check valves are handy installation accessories for piping systems. They are perfect for improving efficiency in sewage diaphragm pumps and preventing back flow. The transparency of the material also helps in troubleshooting and visual inspection. Installation is a breeze with standard PVC cleaner and glue.

SCV-1000C  
SCV-1250C  
SCV-1500C  
SCV-2000C

1" Clear Swing Check Valve  
1-1/4" Clear Swing Check Valve  
1-1/2" Clear Swing Check Valve  
2" Clear Swing Check Valve



## Polyethylene Tanks

Headhunter has over one hundred polyethylene holding tanks, water tanks, and chemical storage tanks from 3 to 175 gallons available for rapid delivery. All fittings are installed per your specifications. We also carry a large selection of non-rectangular tanks. Sizes up to 12,000 gallons available by special order.

Call Headhunter to request our polyethylene tank catalog or visit our website for an quick and easy download.



## Ozone Generator

The OZ-1 ozone generator creates powerful and reactive oxidizer on-site, neutralizing odors and killing bacteria and mold. The ozone oxidizes organics and suspended solids, causing easier solids separation, and clearer effluent.

15-1/2" (394mm) L x 9-1/8" (232mm)W x 3-5/8" (92mm) H



OZ-1(115)  
OZ-1(230)  
OZ-1(230/50)  
OZ-1DIFF

115 VOLT, 60HZ Ozone Generator Kit  
230 VOLT, 60HZ Ozone Generator Kit  
230 VOLT, 50HZ Ozone Generator Kit  
Diffuser Stone for In-tank Installation



## The Grease Grouper

the ultimate grease extractor

The galley of today's luxury yacht or commercial vessels creates just as much kitchen waste as a busy restaurant. The Grease Grouper system eliminates this potential headache by recovering all food scraps and nearly 100% of the grease, oils, and fats from galley waste. Prevents costly drain clogging, and protects on board sewage treatment systems and holding tanks. Discharge of food waste within 3 miles of shore is forbidden under IMO Marpol Annex V and 33 CFR 151 regulations. The Grease Grouper ensures compliance by trapping food wastes & grease before discharge; it also keeps food wastes out of your tanks for effective odor control. Compact and easy to install. The Grease Grouper is the perfect solution.

- Rugged 304 SS construction
- Reliable programmable operation
- Reduces onboard maintenance of grey water collection systems

| Model  | Voltage | Amps | GPM (lps)  | Inlet/Outlet | Length (mm)   | Width (mm) | Height (mm)   |
|--------|---------|------|------------|--------------|---------------|------------|---------------|
| GG13.5 | 115V    | 13   | 13.5 (.86) | 2" (50mm)    | 24 1/2" (622) | 17" (432)  | 11" (279)     |
| GG20   | 115V    | 13   | 20 (1.26)  | 2" (50mm)    | 24 1/2" (622) | 17" (432)  | 16" (406)     |
| GG25   | 115V    | 13   | 25 (1.58)  | 2" (50mm)    | 24 1/2" (622) | 17" (432)  | 16" (406)     |
| GG35   | 115V    | 13   | 35 (1.89)  | 2" (50mm)    | 24 1/2" (622) | 17" (432)  | 17 3/4" (451) |

Note: Allow 9" clearance over top for maintenance access

# Type II MSD Treatment Systems

## USCG Certified Type II MSD & IMO Approved Sewage Treatment Systems



Complete TW-200 Treatment System

Tidal Wave aerobic biological sewage treatment systems are U.S. Coast Guard certified Type II Marine Sanitation Devices. They are also IMO Approved for worldwide compliance with Annex IV Regulation 3(1)(a)(i) of Marpol 73/78, which provide regulations for the prevention of pollution by sewage from ships. The units are accepted in accordance with Resolution MEPC.2(VI) which outlines the performance standards required. Standard models are available to treat 50 to 10,000 US gallons per day (0.2 to 38 cubic meters per day). These systems have no moving parts in the treatment chambers that contact sewage. The biological process is simple, reliable, and efficient. The system makes good environmental sense by working with nature to accelerate the normal biological process. With the addition of oxygen, natural occurring bacteria digest solids and a mild disinfectant is added to kill harmful pathogens. The aerobic process ensures reliable odor free operation. All Tidal Wave systems are available constructed with either 3/16 inch steel or inch marine grade aluminum, coated with ceramic filled epoxy for superior corrosion protection. Custom designs are available to conform to your specific space configuration. Each treatment system includes a blower, a chemical injection pump, and a polyethylene chlorine solution storage tank. Options include electrical control panels, treated effluent discharge pump, and sewage transfer pump see the following pages for application guidance.



- Meets IMO standards
- Reliable biological treatment process
- Odor-free
- Easy to operate
- Compact size
- No moving parts contact sewage

- Virtually maintenance-free
- No harsh chemicals
- Custom models available
- Standard sizes 50-10,000 gallons per day
- Tough, corrosion resistant coating
- Optional high-gloss urethane finish

## 50-300 Gallons Per Day Systems

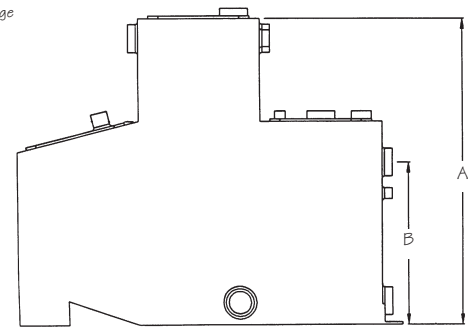
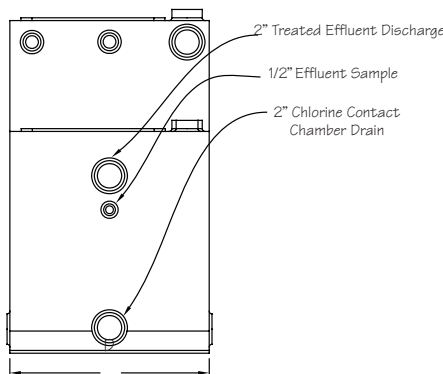
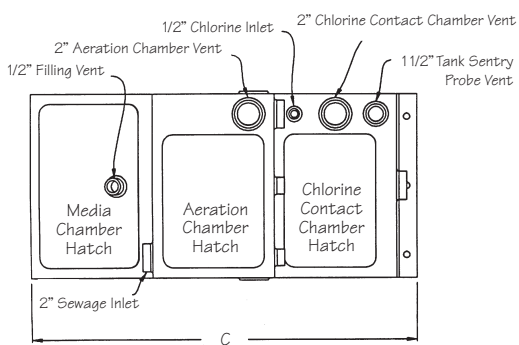

| Model Number | Flow rate Gal per day (Ltr per day) | Persons per 24 hrs | Dimensions in inches (mm) |                 |                |               | Dry Weight lbs (kg) | Operating Weight lbs (kg) |
|--------------|-------------------------------------|--------------------|---------------------------|-----------------|----------------|---------------|---------------------|---------------------------|
|              |                                     |                    | Total Height A            | Disch. Height B | Total Length C | Total Width D |                     |                           |
| TW-50B       | 50(189)                             | 10                 | 30(762)                   | 16(406)         | 38(965)        | 18(457)       | 180(82)             | 580(263)                  |
| TW-50LP      | 50(189)                             | 10                 | 18(457)                   | 12(305)         | 48(1219)       | 24(610)       | 180(82)             | 580(263)                  |
| TW-200B      | 200(757)                            | 40                 | 36(915)                   | 22(559)         | 45(1143)       | 31(787)       | 350(158)            | 1258(571)                 |
| TW-300B      | 300(1135)                           | 60                 | 42(1067)                  | 30(762)         | 45(1143)       | 31(787)       | 415(188)            | 1915(868)                 |



Complete TW-50LP Treatment System

Larger low profile systems available, contact Headhunter for your particular application.

# Commercial Treatment Systems



The Tidal Wave combines proven technology with modern manufacturing techniques to yield a lightweight, reliable, and simple treatment system solution for the rigors of today's commercial offshore environment.

## SPECIFICATIONS

- 5083 marine grade aluminum •A-36 U.S. Steel •SSPC 5 blast profile 1.5-2.0 mils •Ceram Kote 99 Ceramic filled epoxy coating •Data-Couple used for aluminum to steel bonding •Auto-Cad Design supplied



All Tidal Wave Treatment Systems are coated exclusively with CERAM•KOTE 99 ceramic filled epoxy coating.

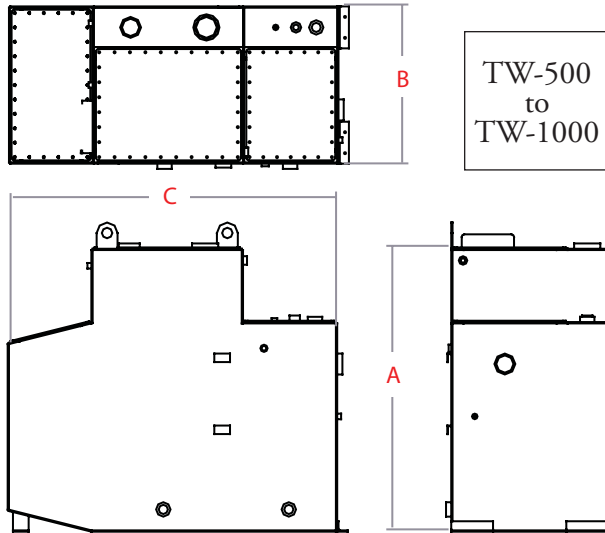

Tidal Wave Treatment Systems can be customized with a variety of options. The TW-5000 model shown is a one-piece unit. It's assembled for easy handling featuring a tablet feeder, explosion proof blower and attached disinfection chamber. One crane lift and this system is installed. Other options include duplex discharge pumps automatically controlled and alternated by the custom electrical control panel.

| Model Number | Flow rate Gal per day (Ltr per day) | Persons per 24 hrs | Dimensions in inches (mm) |          |           | Dry Weight lbs (kg) | Operating Weight lbs (kg) |
|--------------|-------------------------------------|--------------------|---------------------------|----------|-----------|---------------------|---------------------------|
|              |                                     |                    | Height A                  | Width B  | Length C  |                     |                           |
| TW-500       | 500(1892)                           | 100                | 54(1372)                  | 23(584)  | 70(1778)  | 446(201)            | 3267(1470)                |
| TW-800       | 800(3028)                           | 160                | 60(1524)                  | 30(762)  | 72(1829)  | 563(253)            | 3863(1738)                |
| TW-1000      | 1000(3785)                          | 200                | 72(1829)                  | 60(1524) | 46(1169)  | 623(280)            | 4868(2191)                |
| TW-1200      | 1200(4542)                          | 240                | 72(1829)                  | 60(1524) | 52(1321)  | 695(318)            | 5789(2605)                |
| TW-1600      | 1600(6056)                          | 320                | 72(1829)                  | 60(1524) | 64(1626)  | 840(378)            | 7632(3434)                |
| TW-2000      | 2000(7570)                          | 400                | 72(1829)                  | 76(1930) | 72(1829)  | 1015(457)           | 10292(4631)               |
| TW-2400      | 2400(9084)                          | 480                | 72(1829)                  | 80(2032) | 76(1930)  | 1103(496)           | 11695(5263)               |
| TW-3000      | 3000(11355)                         | 600                | 72(1829)                  | 84(2134) | 86(2184)  | 1503(676)           | 14013(6306)               |
| TW-3400      | 3400(12869)                         | 680                | 72(1829)                  | 84(2134) | 96(2438)  | 1540(693)           | 16082(7237)               |
| TW-3800      | 3800(14383)                         | 760                | 72(1829)                  | 84(2134) | 108(2743) | 1590(715)           | 17738(7982)               |
| TW-4200      | 4200(15897)                         | 840                | 72(1829)                  | 84(2134) | 118(2997) | 1800(810)           | 19807(8913)               |
| TW-4600      | 4600(17411)                         | 920                | 72(1829)                  | 84(2134) | 128(3251) | 1900(855)           | 21876(9844)               |
| TW-5000      | 5000(18925)                         | 1000               | 72(1829)                  | 84(2134) | 136(3454) | 2015(907)           | 23531(105889)             |

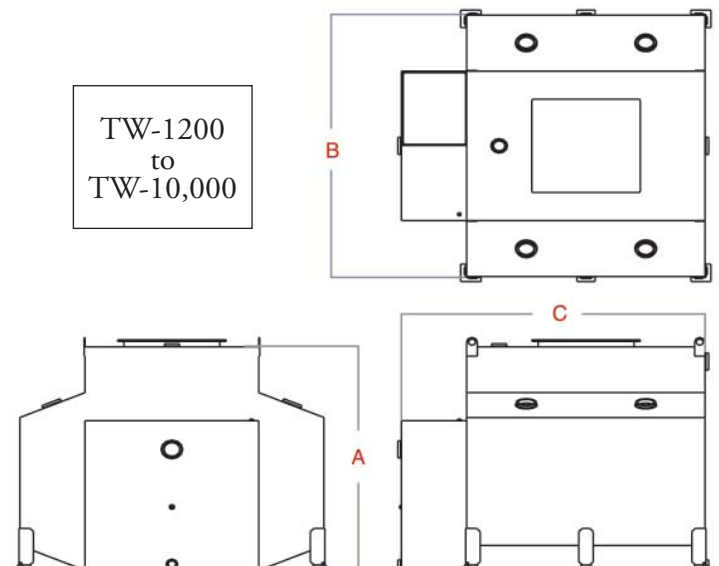

Contact Headhunter engineers for systems larger than 5000 GPD

# Commercial Treatment Systems



A custom skid mounted TW-HMX Tidal Wave MSD is designed for a spacesaving quick and easy installation with integrated discharge pumps, disinfection, and internal hydro-maceration system.



Headhunter application engineers are available to travel all over the world to assist customers before, during, and after system installation.



Headhunter's rugged custom treatment system control panels makes system integration simple and reliable.



Skid mounted 300 gallon per day system with duplex discharge pump system



In order to maintain the highest level of quality and timely delivery, all Tidal Wave MSDs are fabricated inhouse by Headhunter's own motivated team of certified welders, painters, pipe fitters, and electricians.

## OPTIONAL **VAS** VENTURI ASPIRATOR SYSTEM

- Virtually maintenance free
- Enhanced efficiency by hydraulic maceration
- Micro sized bubble diffusion

- Lightweight and compact size
- Low power requirements
- Can be equipped with back up aeration system

The Tidal Wave Venturi Aspirator System (V.A.S.). Is a unique approach to the next generation of sewage treatment systems. Combining innovative technology with over 20 years of industry experience. The V.A.S. provides customers with a reliable aeration alternative for harsh or explosive environments. The V.A.S. system pressurizes the water, infuses it with air creating micro sized bubbles, then recirculates the oxygenated water back into the aeration chamber to produce a well mixed highly conditioned liquid. This process also degasses, and causes a hydraulic shear that precipitates solids and enhances settling, floats grease and adds oxygen (up to 7.5 mg/l) controls odor and corrosion from H<sub>2</sub>S and CO<sub>2</sub>. The Tidal Wave V.A.S. is provided in sizes from 200 to 10,000 U.S. GPD, custom designs can be provided for specific space configurations.



## Custom Design

Headhunter's team of engineers, fabricators, and wastewater specialists work together to take an idea from rough sketch to a 3D CAD model. This unique pool of talent, technology, and creativity allow Headhunter to provide not only superior customer service, but also innovative sewage treatment system solutions in a broad variety of configurations and materials.



## Quality In-house Fabrication & Coating

Many competitors subcontract their fabrication to outside companies. As a result, control over quality and delivery is compromised. At Headhunter, our own in house, highly skilled fabrication team bring to life custom built systems in aluminum, steel, and stainless while maintaining a commitment to our customers for quality and timely delivery.



Modular 300 gallons per day bilge shaped system



## Turn Ideas Into Reality

Whether it's a space-saving modular unit designed for the bilge of a large megayacht, or a skid-mounted turn key package complete with lift stations, and dual language control panels for a foreign navy, the Headhunter team is ready to take on the challenge.



Skid mounted 300 gallon per day system with integrated duplex discharge pump system, and control panel

## Land Based Treatment Systems

Headhunter provides onsite land based package waste water treatment system solutions in a variety of sizes and configurations up to 100,000 gallons per day. Call for details.

# Type II MSD Treatment Systems

## Light Weight Tidal Wave Applications

Perfect for large sailing catamarans, tugboats, or yachts from 65 to 120 feet, the standard model in High Density Polyethylene is the TW-50P. Functionally identical to the fabricated systems, they have the added benefit of being molded of lightweight corrosion proof material. Each system includes treatment tank, efficient linear blower, chemical injection pump, and polyethylene disinfectant solution tank. System shown in picture includes optional Chinook discharge pump. Other options include custom electrical control panels, sewage transfer pumps, or Tank Sentries for monitoring treated effluent level in disinfection chamber.

- Light weight units •Tough, corrosion free •Polyethylene construction



TW-50B/P

| Model     | L (mm)    | W (mm)   | H (mm)   | Dry Weight lbs (kg) | Wet Weight lbs (kg) | AMPS @ 120V | AMPS @ 230V |
|-----------|-----------|----------|----------|---------------------|---------------------|-------------|-------------|
| TW-50B/P  | 39"(990)  | 21"(533) | 30"(762) | 130(58)             | 515(234)            | 2.3         | 1.7         |
| TW-50B/CP | 47"(1194) | 21"(533) | 37"(940) | 160(73)             | 545(247)            | 9.2         | 5.2         |



TW-50B/CP

PLAN VIEW

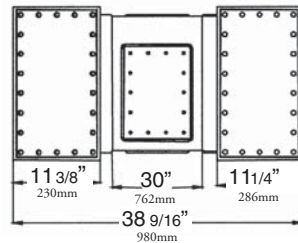

END VIEW

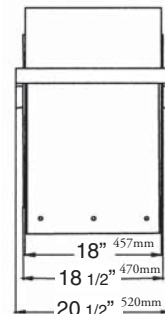

SIDE VIEW

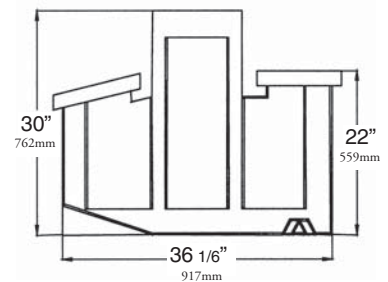

## Lift Stations

Lift stations available in custom sizes, are constructed of steel or 5083 aluminum. All types of options available, from submersible pumps that are platform-mounted and attached to the lid for easy removal to skid mounted corrosion proof poly tanks, and explosion proof pumps. All have a ceramic coating inside and out for long life. Programmable control box permits monitoring of fluid level. Closure for remote alarm available in control box.

*Call Headhunter for your particular application.*



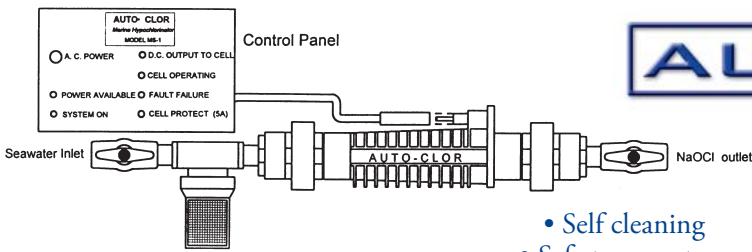

# AUTO CLOR

*marine hypochlorinator*

- Self cleaning
- Safe to operate
- Very easy maintenance
- No extra chemicals or metering pumps required!
- Very simple installation-without interrupting operations
- Long-life, high efficiency electrodes ensure maximum

The AUTO•CLOR is a rugged sodium hypochlorite generator, specifically engineered for marine and offshore applications. Controlled concentrations of chlorine-equivalent sodium hypochlorite are produced through the decomposition of salt water in the electrolytic cell. The AUTO•CLOR is also used to generate disinfectant for several types of Marine Sanitation Devices, and for destroying organic compounds in saline feedwater. All AUTO•CLOR models can be customized to meet your specific requirements.

This fully automated system will eliminate marine growth (biological fouling) from seawater piping systems, including:

- Engine and generator cooling headers
- Ballast water
- Firefighting systems
- Sanitary and sewage lines

Specifications for a standard model AUTO•CLOR include the following:

- Unique timing relay to prolong cell life and regulate hypochlorite concentrations
- Operates in either brackish or salt water
- Pre-set for a continuous flow rate of 3 GPM
- Rated for working pressures to 150 PSI



**Breeze**  
BOWL CLEANER

Cleaning toilets is a Breeze with this new biologically active formula. Breeze contains special enzymes and microorganisms in a super effective mixture engineered to give toilets, sinks, and showers a fresh gleam, clean smell and brilliant shine. Put Breeze's unique mix of waste-degrading bacteria and cleaning agents to work on all your bathroom surfaces and improve the performance of your biological sewage treatment at the same time. Available in one quart bottle, twelve bottles per case.



*Put a predator in your tank*

An all-natural specialized blend of bacterial cultures and nutrients specifically selected for their ability to degrade typical marine and institutional sewage. This synergistic mix of facultative bacteria (both aerobic & anaerobic bacteria) generates a variety of enzymes to help break down starch, fat, oil, grease, protein, and cellulose found in the waste stream. Reduce odors and solids, and improving biological activity in your sewage treatment system the natural way. For peak treatment system performance flush four one ounce bags / 50 gallons of treatment capacity at startup, and add one additional pouch every two weeks. Available in a 20-count plastic container.

Piranha 20 20 pack bottle



**Reveille**  
BIO-WASTE DEGRADER

WAKE UP THE POWER OF NATURE!

Reveille contains over 3/4 million microorganisms per ounce. Scientifically designed to digest wastes, clear drains, and eliminate offensive odors. Optimizing the performance of your sanitary system has never been easier. Simply pour Reveille into drains, shower sumps, toilets, and holding tanks. No mess, no fuss. Available in 22 ounce bottle, twelve bottles per case.



**EfferSan**

Finally, a wastewater disinfectant that is safe and easy to prepare. Disinfection is a necessary step in all wastewater treatment systems. When dropped in a tank of water, this tablet fizzes to dissolve and mix itself, thus creating a safe, non-caustic, and non-irritating disinfectant solution. This solution is injected into the final stage of our Marine Sanitation Device. These tablets are compact, release no odor while in storage and are safe for air transport. This sanitizer is the product of choice for killing those nasty fecal coliform and other pathogenic bacteria, viruses, and offensive odors. One jug with 100 tablets will last for over one year when used with our 50 gal/day sewage treatment system.

EfferSan 100 100 Tablet Container



# Treatment System Control Panels

## Tidal Wave Control Panels

Tidal Wave electrical control panels are designed to simplify the installation of our treatment system's electrical components and other accessories that may be required. All Tidal Wave electrical control panels are built with the latest, industrial grade GE switches, contactors and motor controllers. These motor controllers are listed under UL 508 as manual motor starters and comply with IEC international standards, for worldwide application. GE motor controllers provide Class 10 thermal overload protection, easy current adjustment, and a start, stop, rocker switch with trip indication. All panels provide circuit protection and motor control for the blower, and chemical injection pump used on every treatment system. In addition, the panels shown below provide automated sewage transfer and discharge functions as required by the installed location of the treatment system.

**MET** Listing# E212275

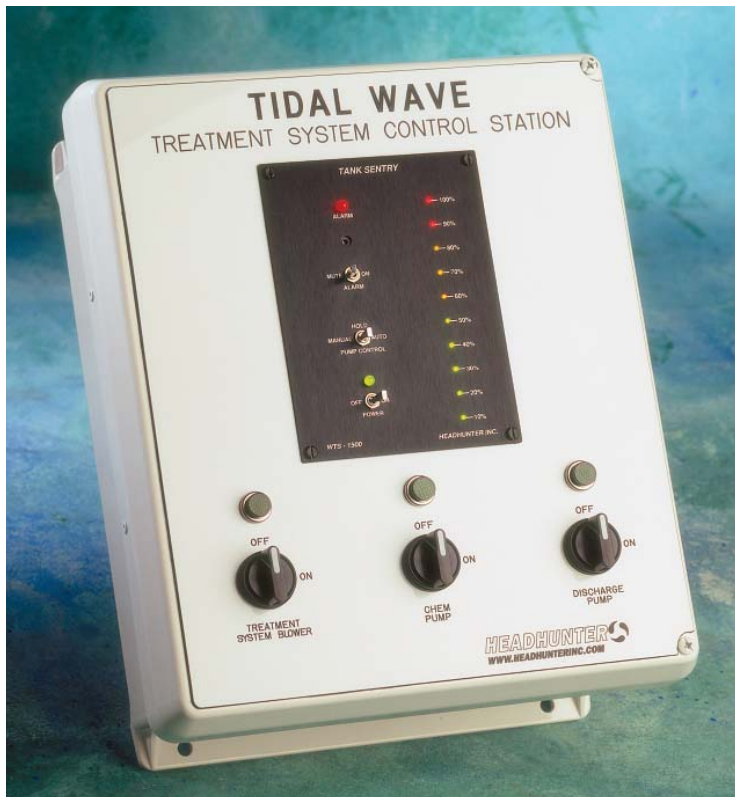

## TWCP-BWL Tidal Wave Control

Complete circuit management for the MSD blower, MSD chemical injection pump, and effluent discharge pump. This electrical panel is used when the toilets flush directly into the Tidal Wave MSD. Includes a complete Tank Sentry WTS-1500B for monitoring the final chamber, the disinfection chamber, of the MSD and automatically activating a discharge pump.

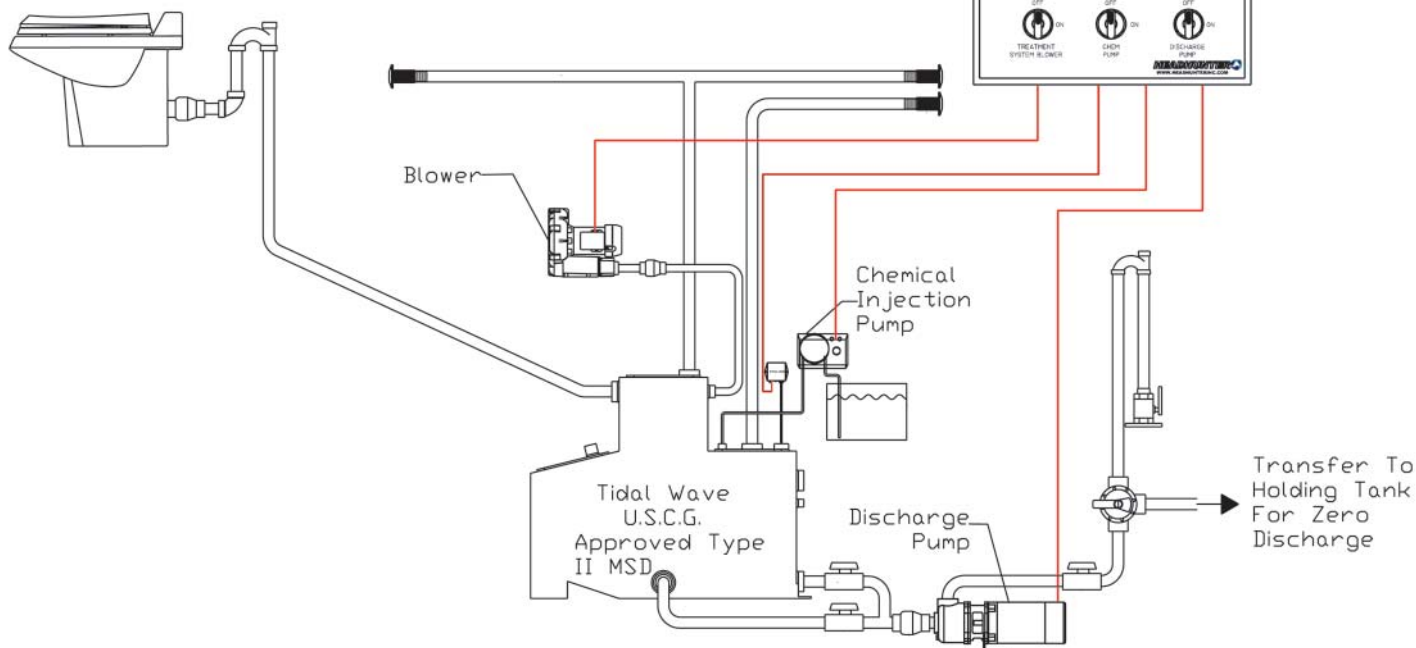

# Treatment System Control Panels

## TWCP-AWL Tidal Wave Control Panel

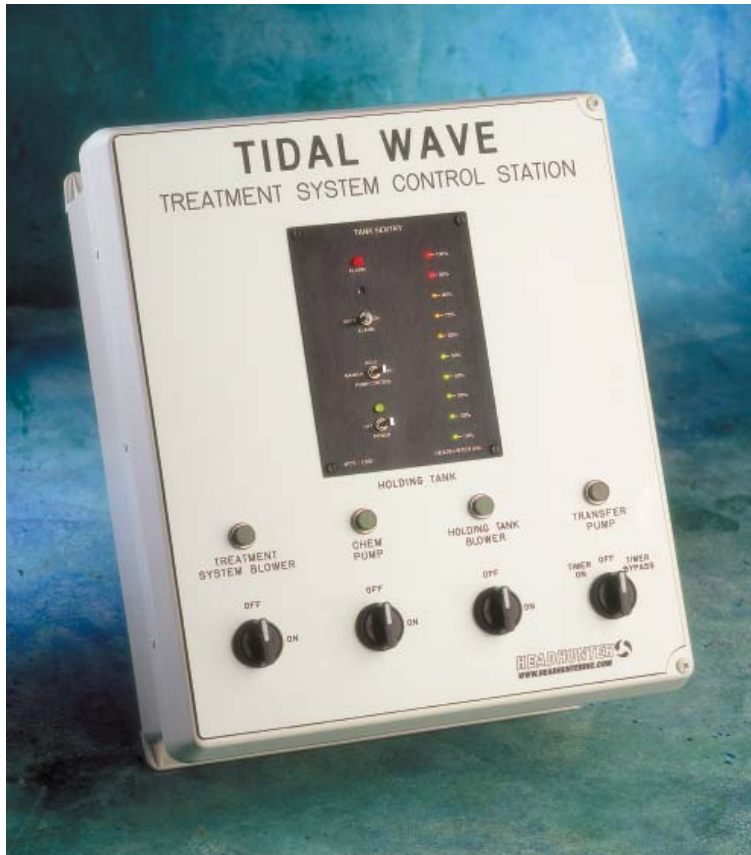

Complete circuit management provided for the holding tank blower, sewage transfer pump, MSD blower, and MSD chemical injection pump. This electrical panel is used when the toilets flush directly into an aerated holding tank, and the sewage is transferred to the Tidal Wave MSD, which is installed above the waterline. Includes a complete Tank Sentry WTS-1500B for monitoring holding tank level, interfaced with a timing relay to automate sewage transfer into the MSD.

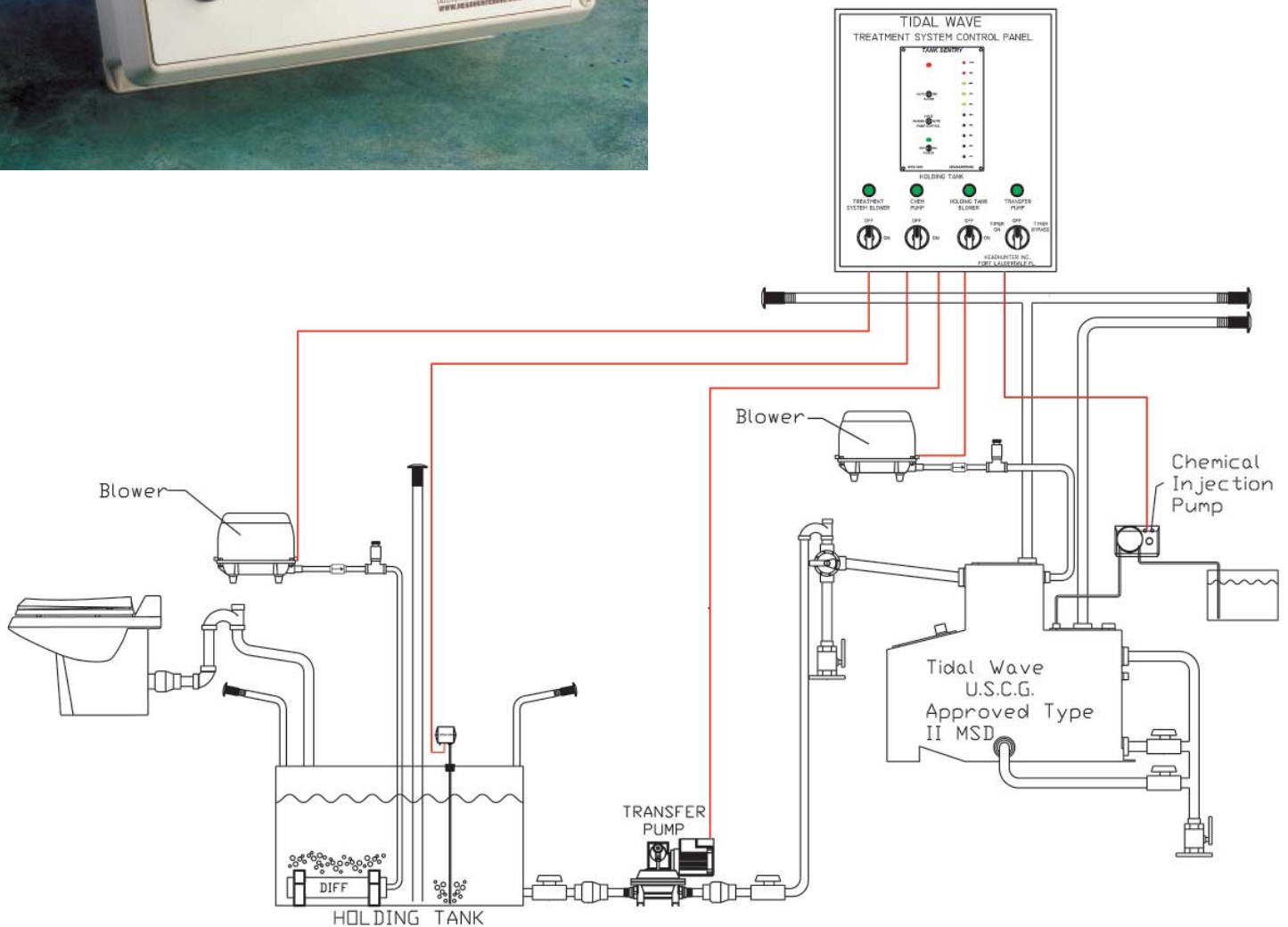

# Treatment System Control Panels

## TWCP-BBWL Tidal Wave Control Panel

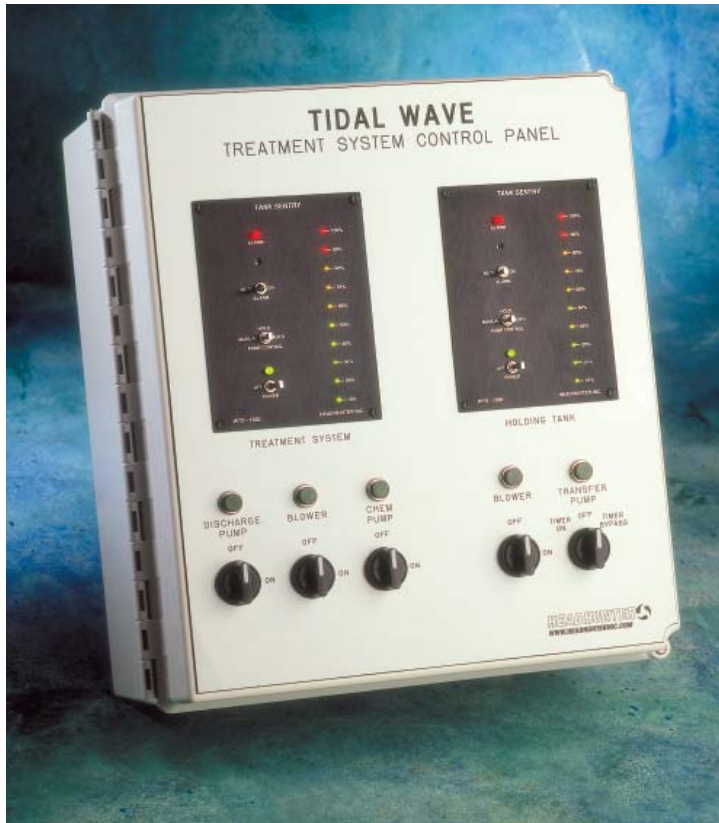

Complete circuit management for a holding tank blower, sewage transfer pump, MSD blower, MSD chemical injection pump, and effluent discharge pump. This panel is used on installations where the toilet flush into an aerated holding tank, and the sewage is transferred into a Tidal Wave MSD that is installed below the waterline. Includes a complete Tank Sentry WTS-1500B for monitoring holding tank level, interfaced with a timing relay to automate sewage transfer into the MSD. Includes a complete Tank Sentry WTS-1500B for monitoring the final chamber, the disinfection chamber, of the MSD and automatically activating a discharge pump.

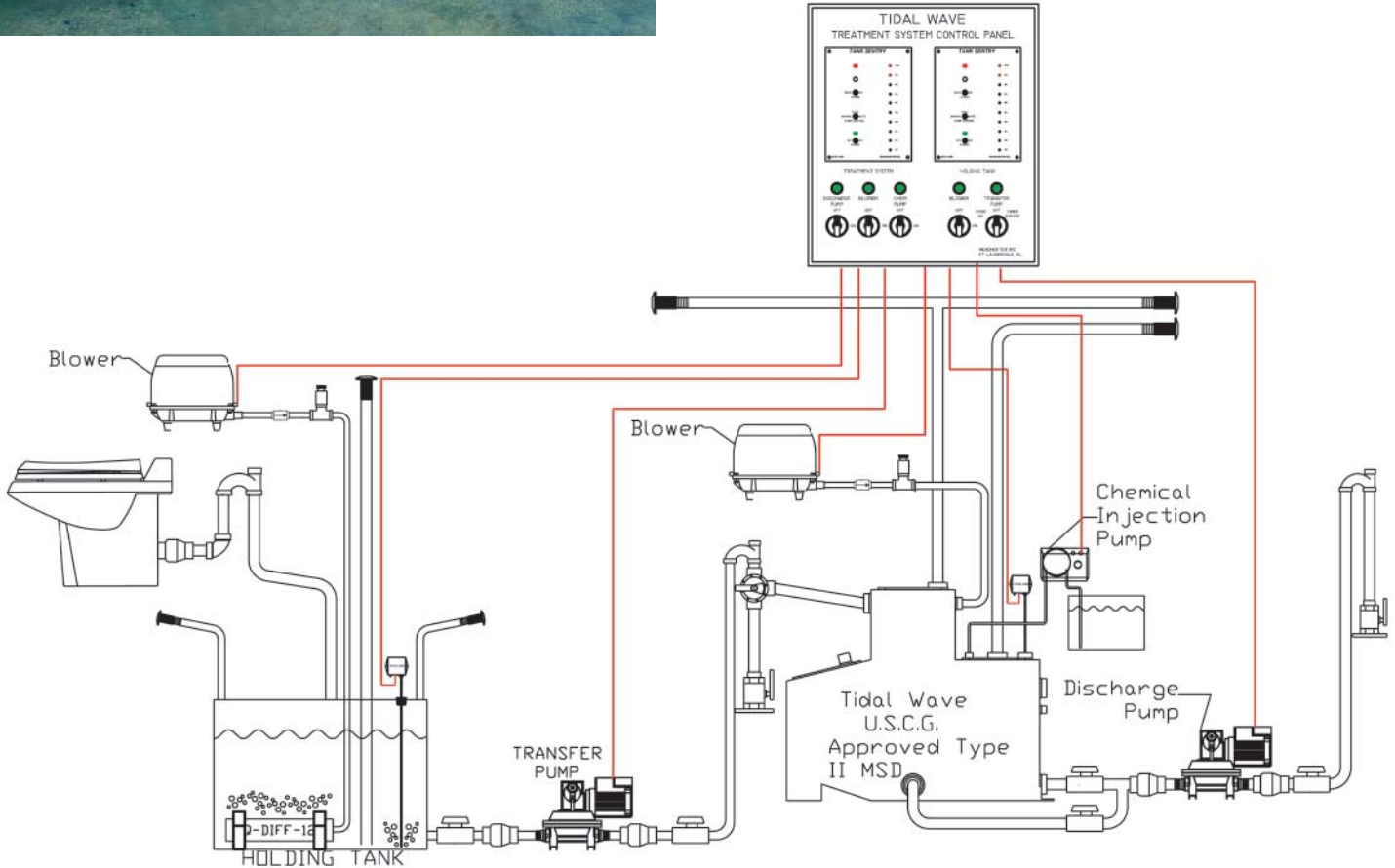

# HMX Treatment Systems



- No chemicals required
- Low maintenance
- Odor Free
- USCG certified-IMO approved for world wide acceptance
- Includes effluent discharge pump for overboard discharge of treated waste
- No extra tanks required
- Easy/automatic operation
- Tough corrosion resistant materials
- Lightweight units
- NRTL Listed construction available for Hazardous Area installation

TIDALWAVE HMX® compact sewage treatment systems are U.S. Coast Guard certified Type II Marine Sanitation Devices that are also IMO Approved for worldwide compliance with Annex IV Regulation 3(1)(a)(i) of Marpol73/78, which provides regulations for the prevention of pollution by sewage from ships. These units are accepted in accordance with Resolution MEPC.2(VI) which outlines the performance standards required. Standard models are available to treat up to 50,000 US Gallons per day (189 cubic meters per day). These systems provide PLC controlled, state of the art processing of onboard sewage. Designed for quick starts and stops with the push of a button, the TIDALWAVE HMX system uses chemical oxidation, hydro-maceration and patented cross-flow separation techniques to thoroughly destroy influent biomass. The optional Electrocatalytic system generates sodium hypochlorite on location from seawater or brine, thus eliminating consumables during operation. The four-stage treatment system provides trouble free treatment of black and gray water with a sterile effluent for disposal. The PLC controller allows the treatment technique to be customized after installation for varying hydraulic and organic loading conditions, or to meet varying performance standards in different areas. These systems are provided in marine grade aluminum or steel construction with a durable, flexible ceramic, epoxy coating for superior corrosion protection.



Listing# E212282



## HMX-500 Series

Designed for up to 48 people and hydraulic loads up to 2,000 gallons per day these systems are offered in two versions. The 500 Series frame mounted version offers a reduced footprint for installations where engine room floor space is at a premium. With the chlorine solution tank, the circulating pump and the effluent sump stacked underneath the first processing chambers, a compact and serviceable system can easily be installed. The control panel is included and mounted separately. Input voltage is typically single phase 115 volt or 220 volt, 50/60 Hz. Pressurized sea water is required for all HMX systems and typically supplied with our Stingray pump on these 500 series systems.

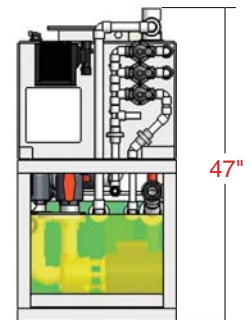
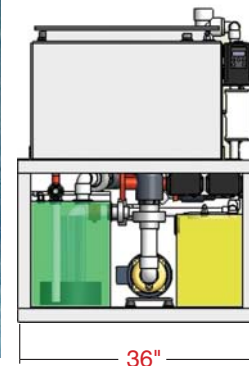
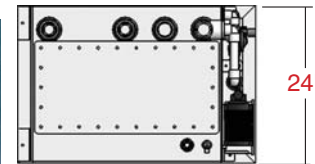

## HMX-500 Low Profile Series



With the same performance characteristics as the frame mounted HMX these low profile models are designed to slip in to tight areas. Remote mounted accessories include the system control panel, chlorine solution tank and optional AUTO CLOR.

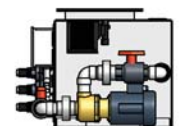
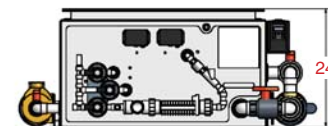
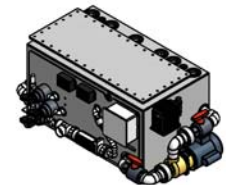
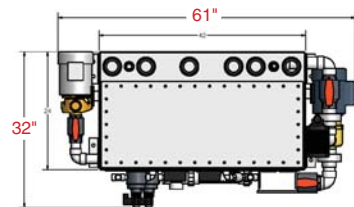

| MODEL        | CAPACITY<br>BLK ONLY | CAPACITY<br>BLK & GRY | DIMENSION<br>(L-W-H) | SHIP<br>WEIGHT | OP. WEIGHT | POWER<br>(kVA) | HYDRAULIC LOAD<br>Gal (m <sup>3</sup> ) / day | BOD LOAD<br>kg (lbs) / day |
|--------------|----------------------|-----------------------|----------------------|----------------|------------|----------------|---|----------------------------|
| TW-HMX-5*1   | 12 PEOPLE            | 8 PEOPLE              | 36"x 24"x 47"        | 325 lbs.       | 835 lbs.   | 5.28           | 600 (2.27)                                    | 1.4 (3.0)                  |
| TW-HMX-5*2   | 24 PEOPLE            | 18 PEOPLE             | 36"x 24"x 47"        | 325 lbs.       | 835 lbs.   | 5.28           | 1,200 (4.54)                                  | 2.8 (6.0)                  |
| TW-HMX-5*3   | 36 PEOPLE            | 28 PEOPLE             | 36"x 24"x 47"        | 325 lbs.       | 835 lbs.   | 5.28           | 1,800 (6.81)                                  | 4.1 (9.0)                  |
| TW-HMX-5*4   | 48 PEOPLE            | 40 PEOPLE             | 36"x 24"x 47"        | 325 lbs.       | 835 lbs.   | 5.28           | 2,000 (7.57)                                  | 5.5 (12.0)                 |
| TW-HMX-5*1LP | 12 PEOPLE            | 8 PEOPLE              | 61"x 32"x 24"        | 325 lbs.       | 835 lbs.   | 5.28           | 600 (2.27)                                    | 1.4 (3.0)                  |
| TW-HMX-5*2LP | 24 PEOPLE            | 18 PEOPLE             | 61"x 32"x 24"        | 325 lbs.       | 835 lbs.   | 5.28           | 1,200 (4.54)                                  | 2.8 (6.0)                  |
| TW-HMX-5*3LP | 36 PEOPLE            | 28 PEOPLE             | 61"x 32"x 24"        | 325 lbs.       | 835 lbs.   | 5.28           | 1,800 (6.81)                                  | 4.1 (9.0)                  |
| TW-HMX-5*4LP | 48 PEOPLE            | 40 PEOPLE             | 61"x 32"x 24"        | 325 lbs.       | 835 lbs.   | 5.28           | 2,000 (7.57)                                  | 5.5 (12.0)                 |

\* Substitute, 1- Aluminum or a 2-Steel, for type of construction

# HMX Treatment Systems

## HMX-2000 through 5000 Series

With capacities up to 50,000 gallons per day these are the biggest marine sewage treatment systems you'll find anywhere. The patented cross flow filtration technique, treats large hydraulic loads in a small space. All Tidal Wave HMX systems can be programmed once installed to meet changing performance criteria, and varying hydraulic or organic loading. These are the perfect systems for commercial applications where space is at a premium, and performance under all situations is expected. Type test approved to USCG and IMO performance standards these systems can easily be configured to exceed the most stringent new codes.



TW-HMX-3202 Class I Div II built for offshore platform

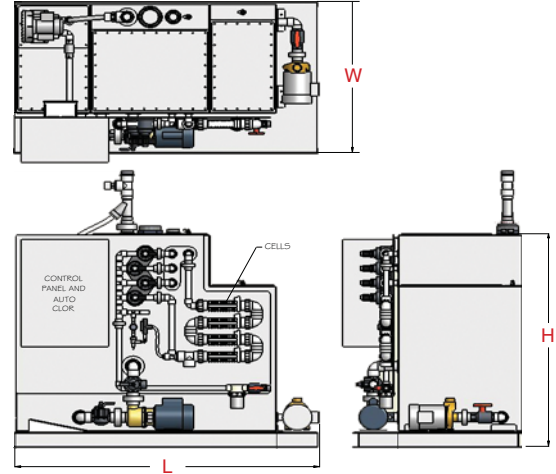

| MODEL       | CAPACITY BLK ONLY | CAPACITY BLK & GRV | DIMENSION (L-W-H) | SHIP WEIGHT | OP. WEIGHT  | POWER (kVA) | HYDRAULIC LOAD Gal (m <sup>3</sup> )/day | BOD LOAD kg (lbs)/day |
|-------------|-------------------|--------------------|-------------------|-------------|-------------|-------------|--|-----------------------|
| TW-HMX-2*02 | 60 PEOPLE         | 48 PEOPLE          | 60"x 38"x 45"     | 500 lbs.    | 1,600 lbs.  | 5.28        | 3,000 (11.4)                             | 6.8 (15)              |
| TW-HMX-2*03 | 72 PEOPLE         | 56 PEOPLE          | 60"x 38"x 45"     | 500 lbs.    | 1,600 lbs.  | 6.20        | 3,600 (13.6)                             | 8.2 (18)              |
| TW-HMX-2*04 | 84 PEOPLE         | 65 PEOPLE          | 60"x 38"x 45"     | 500 lbs.    | 1,600 lbs.  | 6.20        | 4,200 (15.9)                             | 9.5 (21)              |
| TW-HMX-2*05 | 96 PEOPLE         | 75 PEOPLE          | 60"x 38"x 45"     | 500 lbs.    | 1,600 lbs.  | 6.20        | 5,000 (18.9)                             | 11 (24)               |
| TW-HMX-3*02 | 160 PEOPLE        | 125 PEOPLE         | 74"x 42"x 58"     | 635 lbs.    | 6,250 lbs.  | 7.35        | 8,000 (30.3)                             | 18 (40)               |
| TW-HMX-3*03 | 200 PEOPLE        | 160 PEOPLE         | 74"x 42"x 58"     | 635 lbs.    | 6,250 lbs.  | 7.35        | 10,000 (37.9)                            | 23 (50)               |
| TW-HMX-3*04 | 240 PEOPLE        | 190 PEOPLE         | 74"x 42"x 58"     | 635 lbs.    | 6,250 lbs.  | 7.35        | 12,000 (45.4)                            | 27 (60)               |
| TW-HMX-4*02 | 300 PEOPLE        | 240 PEOPLE         | 74"x 43"x 68"     | 725 lbs.    | 9,575 lbs.  | 8.50        | 15,000 (56.8)                            | 34.0 (75)             |
| TW-HMX-4*03 | 400 PEOPLE        | 320 PEOPLE         | 74"x 43"x 68"     | 725 lbs.    | 9,575 lbs.  | 8.50        | 20,000 (75.7)                            | 45.3 (100)            |
| TW-HMX-4*04 | 500 PEOPLE        | 400 PEOPLE         | 74"x 43"x 68"     | 725 lbs.    | 9,575 lbs.  | 15.40       | 25,000 (94.6)                            | 56.6 (125)            |
| TW-HMX-4*05 | 600 PEOPLE        | 480 PEOPLE         | 74"x 43"x 68"     | 725 lbs.    | 9,575 lbs.  | 15.40       | 30,000 (113.6)                           | 68.0 (150)            |
| TW-HMX-5*02 | 700 PEOPLE        | 560 PEOPLE         | 80"x 48"x 68"     | 850 lbs.    | 11,350 lbs. | 15.40       | 35,000 (132.50)                          | 79.3 (175)            |
| TW-HMX-5*03 | 800 PEOPLE        | 640 PEOPLE         | 80"x 48"x 68"     | 850 lbs.    | 11,350 lbs. | 15.40       | 40,000 (151.40)                          | 90.7 (200)            |
| TW-HMX-5*04 | 900 PEOPLE        | 720 PEOPLE         | 80"x 48"x 68"     | 850 lbs.    | 11,350 lbs. | 18.85       | 45,000 (170.34)                          | 102.0 (225)           |
| TW-HMX-5*05 | 1,000 PEOPLE      | 800 PEOPLE         | 80"x 48"x 68"     | 850 lbs.    | 11,350 lbs. | 21.00       | 50,000 (189.27)                          | 113.3 (250)           |

\* Substitute, 1- Aluminum or a 2-Steel, for type of construction

## HMX Control Panels

Each HMX control panel includes industrial grade switches, contactors, and motor controllers providing complete overload protection and visual system status during operation. Level indication in the primary macerating chamber, and the dechlorination chamber is visually displayed. Equipment status and alarms are displayed via indicator lights, internal LCD display or on-screen icons. A frequent option is the addition of monitors for the ship's on-board waste tank and control of associated sewage transfer pumps to automate the entire collection and treatment process. An upgraded industrial PLC with touch-screen user interface offers automated integration of the AUTO CLOR alarms, and enables prioritizing of several collection tanks onboard so that the treatment capabilities of your Tidal Wave HMX are thoroughly optimized.



TW-HMX-3203 built for Galapagos cruise ship



**MET** Listing# E212275

# Custom Control Panels



Headhunter's Custom Control Department has the capability to design and assemble virtually any custom control panel design imaginable. Many OEM's take advantage of our unique capability to significantly simplify their installations by combining our Tank Sentry fluid level controls with PLC's, motor controllers, and motor starters, in a wide variety of enclosures. All custom control panels include detailed AutoCAD documentation of wiring and control logic.

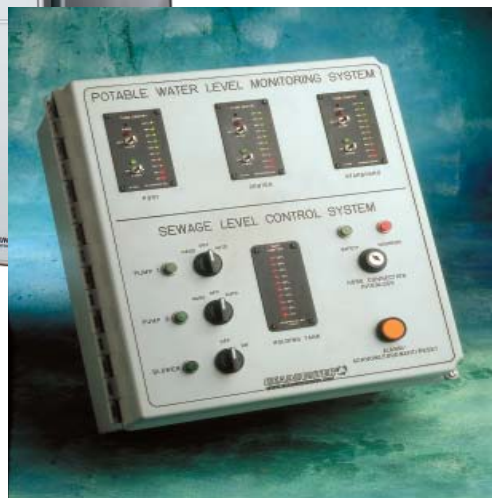

- PLC logic controller integration
- Built in motor controllers and motor starters
- Custom engraving and panel colors
- True plug and play integration

Custom combined Tidal Wave/Gray Water System



Typical interior layout of a custom Headhunter control panel showing shipboard safe nonexposed connection and tidy integration of all electrical components.



Headhunter's experienced state of the Art control panel department thoroughly test and document every control panel prior to delivery.

# Tank Sentry Fluid Level Monitors

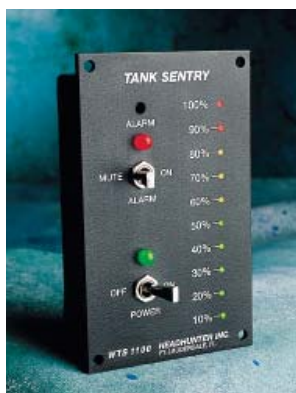

Our programmable fluid level monitors provide reliable and accurate Tank level indication. There are no moving parts to foul, or electrical components inside the tank. Unaffected by floating solids or stray current, Tank Sentry is the ideal solution for the toughest of fluid level monitoring assignments. All Tank Sentrys operate on 12 to 32 volt DC power. With a few simple adjustments they are capable of monitoring tanks from 6 inches to 6 feet deep, right out of the box. All models have 10% incremental LED displays.

All units include a monitor panel, 30 feet per tank of shielded 18/3 wire, 1 SYM-2Q sensor module per tank, 10 feet of urethane tubing per tank, 1 TPA-1250 1-1/4" tank penetration assembly per tank, and 3 heat shrink wire connectors. Installation accessories such as extra wire, mounting flanges, and pump relays are sold separately.

## SPECIFICATIONS

- No electrical or moving parts in contact with fluid
- Simple calibration for tanks from 6" (152mm) - 108" (2.7m)
- Programmable alarms with mute switch
- Programmable pump controls
- Constant precise tank status information
- Models for sewage, water, diesel, and other fluids
- Easily combined with onboard computer systems

|                       |   |
|-----------------------|---|
| Input DC Voltage      | 10V - 60V                                       |
| Signal                | 0.95-6.80 VDC                                   |
| Current               | 500mA Per Tank                                  |
| Tank Fitting Required | 1-1/4" FPT Or SAE-Flange                        |
| Switch Capabilities   |   |
| Remote Alarm          | 3 Amps DC, $R_{on} < 300\Omega$ , $t_s > 250ms$ |
| Pump Control          | 3 Amps DC, $R_{on} < 300\Omega$ , $t_s > 250ms$ |
| Approvals             | UL Listed                                       |



### WTS-1500B

Ideal for holding and grey water tanks. Set the level to initiate and terminate the pumpout with simple to operate slide switches. Pump controller operates D.C. relays for switching AC or DC pumps (order relays separately). Also features high level audible and visible alarm.

Panel dimensions 6-1/8" (156mm) x 4-5/8" (118mm)

**TS-1501B** This model engages relay at low level, and disengages at high level to provide a programmable "pump up" control, and low level alarms. Used to fill day tank from main tank.

Panel dimensions 6-1/8" (156mm) x 4-5/8" (118mm)

### TS-2000B

Features both high and low level audible and visual alarms with remote alarm capability. Ideal for diesel tanks where fill without spill is desired.

Panel dimensions 6-1/8" (156mm) x 4-5/8" (118mm)

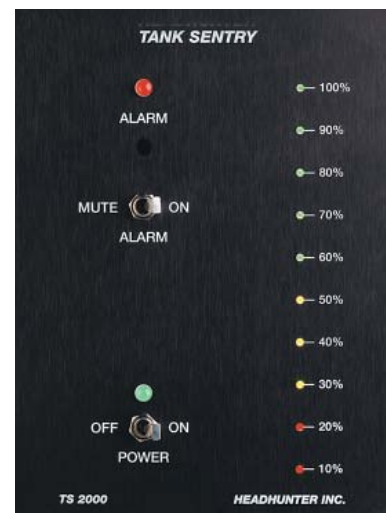

Slide switches make programming alarm and pump controls a breeze.

| Model                        | High Level Alarm | Level Indication | Low Level Alarm | Pump Control | Remote Alarm Capability |
|------------------------------|------------------|------------------|-----------------|--------------|-------------------------|
| WTS-1500B                    | x                | x                |                 | x            | x                       |
| TS-1501B                     |                  | x                | x               | x            | x                       |
| TS-2000B                     | x                | x                | x               |              | x                       |
| WTS 1100B                    | x                | x                |                 |              | x                       |
| TS-2500B                     |                  | x                | x               |              | x                       |
| TS-3000 Series (3001B-3005B) |                  | x                |                 |              |                         |

# Tank Sentry Fluid Level Monitors



## WTS-1100B

Designed for precise monitoring of tanks where high level visual and audible alarms are required. Ideal for holding tanks. Features dry closure for remote alarm or “do not flush” lights.

Panel dimensions  
2-3/8” x 3-7/8”  
60mm x 98mm



## TS-2500B

Designed for precise monitoring of tanks where low level visible and audible alarms are required. Ideal for diesel or water tanks. Features dry closure for remote alarm or dry tank shutdown of freshwater pump.

Panel dimensions  
2-3/8” x 3-7/8”  
60mm x 98mm



## Tank Sentry 3000 Series

Developed to monitor multiple tanks on a single compact panel, the 3000 series provides tank level indication for up to five tanks. These tanks can contain different fluids. Use the 3000 series in conjunction with other Tank Sentrys as repeaters that provide tank information in different locations. The last number of the part number designates the number of tanks on the system.

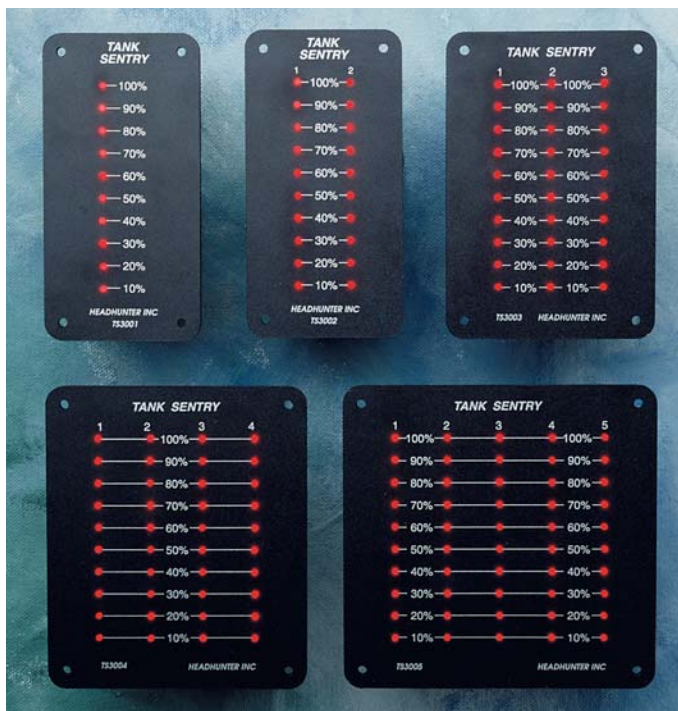

- Delivers visual information at a glance
- Continuous, simultaneous display of up to 5 tanks
- Compact display
- Can be combined with other Tank Sentrys to provide dual monitoring stations

| Complete* | Panel only** | Panel Size (in) | Panel Size (mm) |
|-----------|--------------|-----------------|-----------------|
| TS-3001B  | MO-3001      | 2-1/8 x 4-1/8   | 54 x 105        |
| TS-3002B  | MO-3002      | 2-1/8 x 4-1/8   | 54 x 105        |
| TS-3003B  | MO-3003      | 2-7/8 x 4-1/8   | 73 x 105        |
| TS-3004B  | MO-3004      | 3-1/2 x 4-1/8   | 89 x 105        |
| TS-3005B  | MO-3005      | 4-3/16 x 4-1/8  | 106 x 105       |
| TS-3006B  | MO-3006      | 4-1/8 x 4-1/8   | 106 x 105       |

\*Complete kit includes 1 monitoring panel, 30 feet per tank of shielded 18/3 wire, 1 SYM sensor module per tank, 10 feet of urethane tubing per tank, 1 TPA-1250 1-1/4” MPT tank penetration assembly per tank and 3 heat shrink wire connectors. \*\*MO-300x is a monitoring panel only. Combine this with another Tank Sentry to provide multiple monitoring stations.

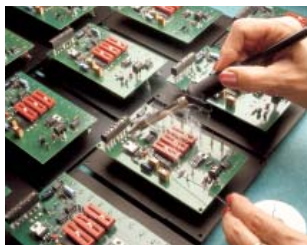

## Quality Manufacturing

Headhunters own skilled technicians test each Tank Sentry system as many as seven different times during their assembly including a 6 hour “burn in” and an 8 hour computer monitored cycle test. All Headhunter electronic products are then protected from the harsh marine environment by our unique UL listed epoxy encapsulation process.



## Tank Sentry Installation Diagrams

**Figure 1** illustrates a typical installation of a single Tank Sentry such as WTS 1500B with optional remote alarm and pump control.

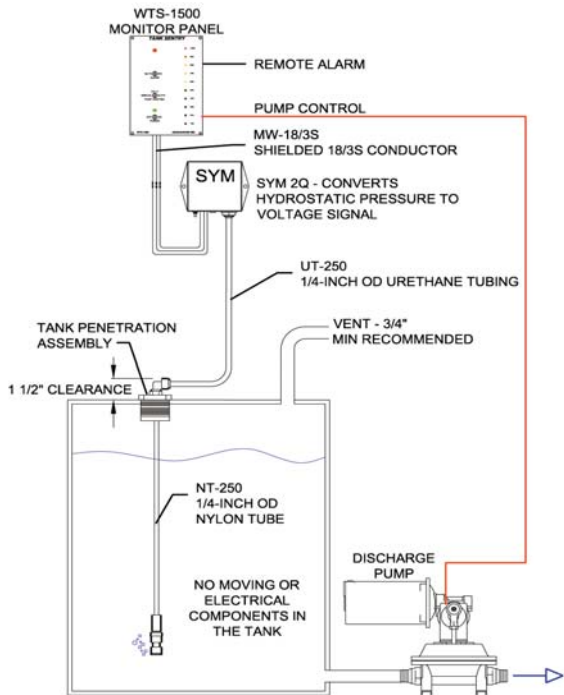

**Figure 2** illustrates a typical installation of a TS-3004. This might include two fuel tanks, one water tank and one holding tank.

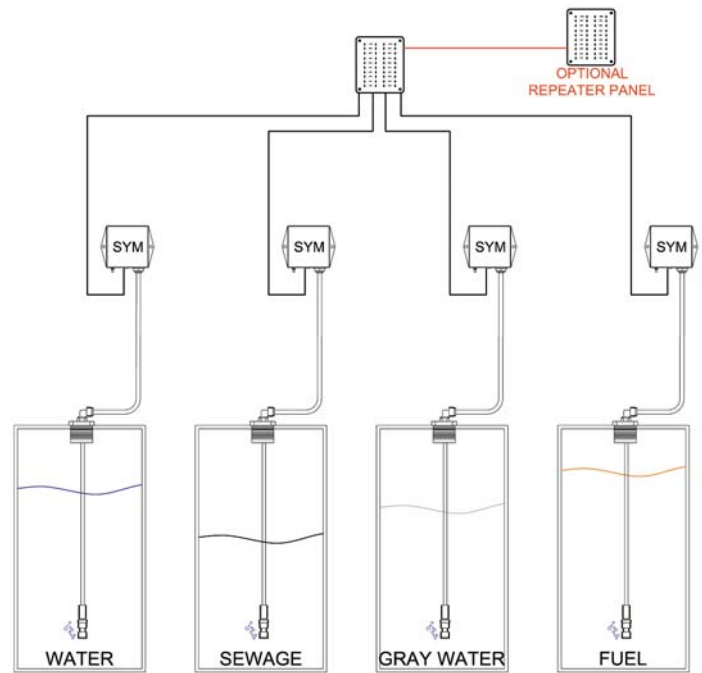

1-1/4" MPT plug mounts available in PVC, 316 stainless steel, and bronze.



SAE flange mounts are available in aluminum, 316 stainless steel, and brass for all models except 4000 Series.



Fireproof Swagelock® tubing is standard with all commercial Tank Sentry Penetration Assemblies. End connectors are brass or 316 stainless steel, depending on the tank penetration fitting selected.

## Commercial TANK PENETRATION assemblies

Headhunter's Commercial Tank Penetration Assemblies are precision machined from fireproof materials for safety and confidence in your fuel tank monitor installations. (excludes PVC versions).

Each unit uses fireproof hose and heavy-duty bronze or stainless steel fittings from Swagelock®, and each has passed Underwriters Laboratories test for flame resistance in non-integral marine fuel tanks.

*Add suffix from the table below to the end of Tank Sentry model number to specify Tank Penetration Assembly desired.*

| Construction    | SAE Flange | 1-1/4" MPT |
|-----------------|------------|------------|
| Stainless Steel | FLGS       | SST        |
| Bronze          | FLGB       | BRS        |
| Aluminum        | FLGA       | N/A        |
| PVC             | N/A        | Standard   |



# Tank Sentry Fluid Level Monitors

## SYM 23Q Fluid Level Sensor



The SYM 23Q is an excellent analog fluid level sensor for computer, PLC, and all other vessel monitoring applications. The SYM 23Q monitors the fluid level of the tank by utilizing an integrated solid state controlled silent bubbler system to measure the hydrostatic pressure at the bottom of the tank and convert it to an accurate analog voltage signal. Featuring a universal 10-60VDC input and a .95-6.80VDC signal output, the SYM 23Q is suitable for all water based and oil based fluids. Another unique feature of the SYM 23Q is its ability to accurately monitor any depth tank from 10 inches to 110 inches. The signal is compatible with the standard line of Headhunter Tank Sentry monitor panels. Many OEM's take advantage of its ability to reduce inventory requirements for their level sensor needs, since one SYM 23Q can be easily configured for a wide variety of tanks unlike most conventional custom OEM fluid monitors.

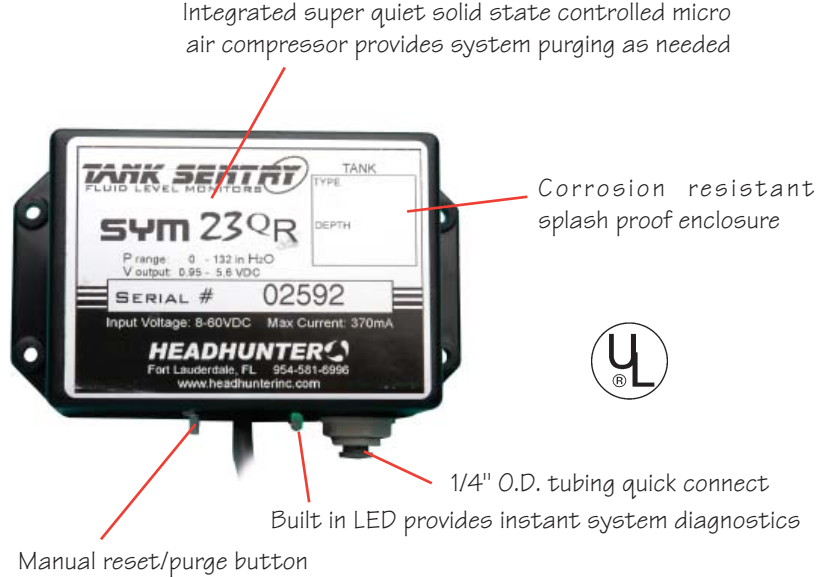

The SYM 23QR is recommended for tanks from 32" to 132" deep.

For shallow tanks less than 32" the SYM 23QS is recommended.

SYM-23QS  
SYM 23QR

tanks from 0" to 32" deep  
tanks from 32" to 132" deep

| SYM-23QR                       |                    |
|--------------------------------|--------------------|
| DEPTH H <sub>2</sub> O In (mm) | AVG SIGNAL VOLTAGE |
| 0                              | 0.9757             |
| 6 (152)                        | 1.0614             |
| 12 (305)                       | 1.3792             |
| 18 (457)                       | 1.5949             |
| 24 (610)                       | 1.7873             |
| 30 (762)                       | 1.9829             |
| 36 (914)                       | 2.1588             |
| 42 (1067)                      | 2.3881             |
| 48 (1219)                      | 2.5698             |
| 54 (1372)                      | 2.7647             |
| 60 (1524)                      | 2.9694             |
| 66 (1676)                      | 3.1734             |
| 72 (1829)                      | 3.362              |
| 78 (1981)                      | 3.5581             |
| 84 (2134)                      | 3.7628             |
| 90 (2286)                      | 3.9347             |
| 96 (2438)                      | 4.1366             |
| 102 (2591)                     | 4.3353             |
| 108 (2743)                     | 4.5266             |
| 114 (2895)                     | 4.7017             |
| 120 (3048)                     | 4.9032             |
| 126 (3200)                     | 5.1913             |
| 132 (3353)                     | 5.3159             |
| 138 (3505)                     | 5.4983             |

| SYM-23QS                       |                    |
|--------------------------------|--------------------|
| DEPTH H <sub>2</sub> O In (mm) | AVG SIGNAL VOLTAGE |
| 0 (0)                          | 0.507              |
| 3 (76)                         | 0.976              |
| 6 (152)                        | 1.457              |
| 9 (229)                        | 1.911              |
| 12 (305)                       | 2.38               |
| 15 (381)                       | 2.879              |
| 18 (457)                       | 3.348              |
| 21 (533)                       | 3.819              |
| 24 (610)                       | 4.314              |
| 27 (686)                       | 4.763              |
| 30 (762)                       | 5.274              |
| 33 (838)                       | 5.768              |
| 36 (914)                       | 5.957              |

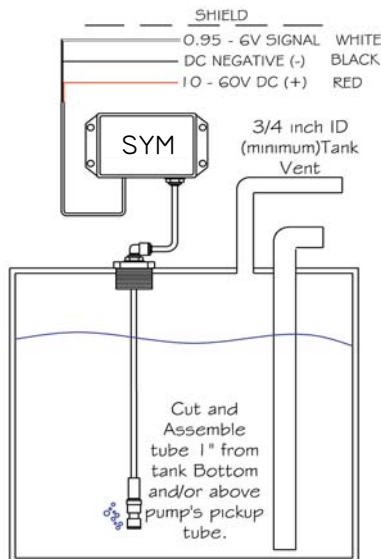

### SPECIFICATIONS

|                   |   |
|-------------------|---|
| DC Voltage        | 10V To 60V DC   |
| Current           | 500mA   |
| Signal            | 0.95 - 6.80 VDC   |
| SYM Dimensions    | 5-1/2" L x 3-1/4" W x 2" D<br>140mm L x 83mm W x 51mm D |
| Tank Fitting Req. | 1-1/4" FPT Or SAE-Flange                                |

For each Tank Sentry order one SYM 23Q-Kit. Each SYM 23Q-Kit includes 1x SYM 23Q sensor module, 10' of UT-250 1/4" O.D. urethane tubing, or 10' of TSPB-4YW 1/4" I.D. fire retardant swagelock hose for commercial applications, and a tank penetration assembly with enough material to monitor up to 6' deep.

Add suffix from the table below to the end of SYM 23Q Kit model number to specify Tank Penetration Assembly desired.

| Construction    | SAE Flange | 1-1/4" MPT |
|-----------------|------------|------------|
| Stainless Steel | FLGS       | SST        |
| Bronze          | FLGB       | BRS        |
| Aluminum        | FLGA       | N/A        |
| PVC             | N/A        | Standard   |

# Tank Sentry Fluid Level Monitors



## TS-4000 Tank Sentry Alarm Systems

The TS-4000 is as simple as it gets for reliable single-point level indication, and as with all of our Tank Sentry series, no mechanical or electrical components contact the fluid being monitored. When liquid rises above a preset level in the tank being monitored, an innovative, pressure-activated switch signals both a visual alarm (a brilliant red blinking LED), and a piercing high-decibel audible alarm.

The TS-4000 also features a unique On-Off-Mute toggle switch with a built-in bi-color LED indicator. When the switch is in its central, "off" position, the LED is unlit. When the system is switched "on", the LED is green, and when the system is on but the audible alarm is muted ("mute"), the LED is yellow.

- Provides reliable high level indication
- Ideal for holding tanks
- Can be used as secondary remote alarm
- Simple to install
- Operates on 12V, 24V, or 32V DC
- No moving parts
- UL listed for water-based fluids
- Ignition protected

## REMOTE ALARM OPTIONS

The monitor panel (MO-4000) can be purchased separately and used as a remote alarm for high or low level indication, in conjunction with one of our existing line of Tank Sentry products. For example, Tank Sentry model WTS-1100B could be used to monitor a holding tank, and the MO-4000 (B or W) could be installed in a location where continuous monitoring of the holding tank is not required, but high level notification is desired.

## SPECIFICATIONS

|                          |   |
|--------------------------|---|
| Dimensions               | 3"(76mm) H x 2"(51mm) W x 1.35"(35mm) D |
| Voltage                  | Operates on 12V, 24V, or 32V DC         |
| Amps                     | .780 Amps Max @12V DC                   |
| Temperature Range        | 40° F-150° F (4° C-66° C)               |
| TPA-4125 Switch Contacts | Features NO and NC, .125A@125V AC       |
| TPA-4125 Material        | SCH. 80 PVC, Polyurethane, Polysulfone  |
| Panel Material           | Anodized/Powder Coated Aluminum,        |
| Polyurethane             |   |
| Deadband Range           | 2" (51mm) Water                         |

Each complete TS-4000 system consists of:

- 1x MO-4000 (B or W)
- 1x TPA-4125
- 4x Stainless Steel Black Oxide Mounting Screws
- 2x 16-Gauge Female Quick-Connect Wire Connectors
- 30ft Of 16-Gauge, Two-Conductor Marine Cable

|           |  |
|-----------|--|
| TS-4000B  | Complete High-Level Alarm System w/Black Panel       |
| TS-4000W  | Complete High-Level Alarm System w/White Panel       |
| MO-4000B  | Remote Alarm Panel Only w/Black Panel                |
| MO-4000W  | Remote Alarm Panel Only w/White Panel                |
| TPA-4125  | 1-1/4" MPT Tank Penetration Assembly                 |
| TS-ENC2X3 | Enclosure Box For Bulkhead Mount Of MO-4000 (B or W) |
| FLG-1250  | 1-1/4" PVC Tank Flange                               |

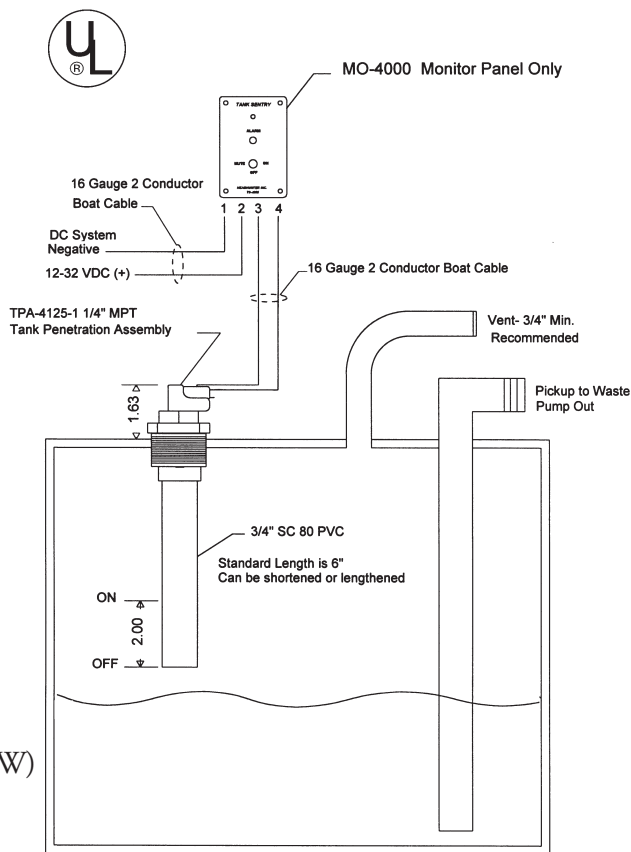

# Tank Sentry Fluid Level Monitors



The TSi Tank Sentry is our most advanced and accurate fluid level monitoring system available. The TSi system sports stylish blue, amber, or red 20 LED bargraph displays on designer black or white panels and is packed with smart features such as digital network communication, calibration memory back up, tank labeling, true volumetric fluid level indication, and programmable alarm and pump control. Standard NMEA 2000 protocol via RS 485 connection utilized by the TSi system makes integration with third party computer monitoring systems simple and painless.

## TSi-1515 Series

Ideal for tanks requiring accurate volumetric level indication, alarms, and automatic/manual/hold pump up or pump down control, the TSi 1515 features LCD display of the tank name, and fluid level in gallons or liters, high and low level alarms, and 20 LED bargraph display. Pump "ON" and "OFF" settings are easily programmed in 1% increments via easy to navigate menu. Order TSi-RCU Relay Control Unit separately to complete system.

Dimensions- 4" x 6" x 3 3/4" deep  
102mm x 152mm x 95mm deep

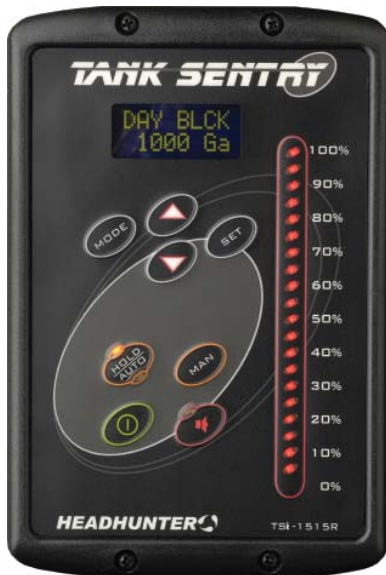

TSi-1515R-B  
Red LEDs on Black Panel



TSi-1515Y-B  
Amber LEDs on Black Panel

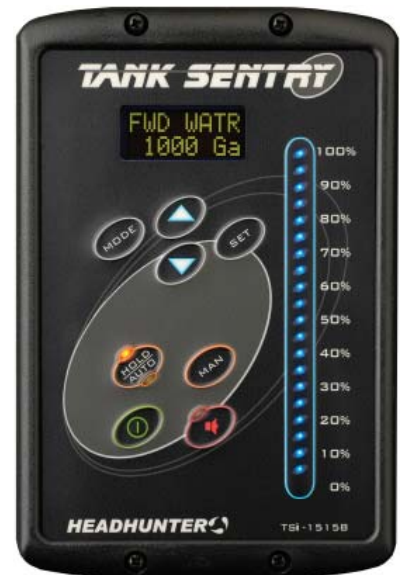

TSi-1515B-B  
Blue LEDs on Black Panel

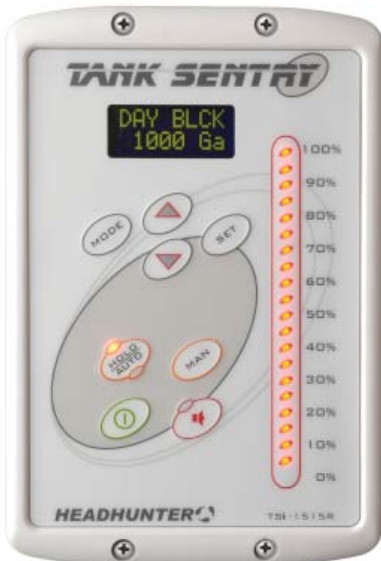

TSi-1515R-W  
Red LEDs on White Panel

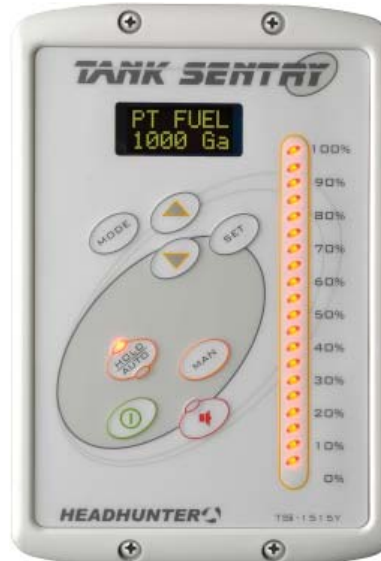

TSi-1515Y-W  
Amber LEDs on White Panel



TSi-1515B-W  
Blue LEDs on White Panel

## TSi-2525 Series

Ideal when accurate volumetric level indication and alarms are desired, the TSi-2525 features LCD display of the tank name, and fluid level in gallons or liters, high and low level alarms, and 20 LED bargraph display.

Dimensions- 4" x 6" x 3 3/4" deep  
102mm x 152mm x 95mm deep



TSi-2525R-B  
Red LEDs on Black Panel



TSi-2525Y-B  
Amber LEDs on Black Panel

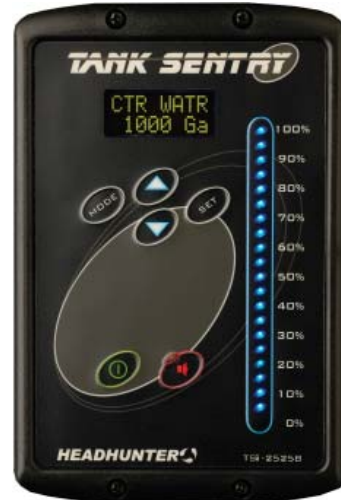

TSi-2525B-B  
Blue LEDs on Black Panel



TSi-2525R-W  
Red LEDs on White Panel

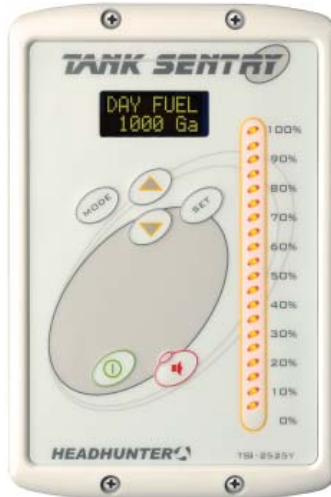

TSi-2525Y-W  
Amber LEDs on White Panel



TSi-2525B-W  
Blue LEDs on White Panel

## TSi-3030 Series

The most compact bargraph display available in the TSi family, the 3030's are ideal for applications requiring stylish, simple tank level indication in areas where space is a premium. Simple push button calibration, and included Tank Label Kit make the 3030's a simple solution.

Dimensions- 1 5/8" x 6" x 4 1/4" deep  
41mm x 152mm x 108mm deep

- TSi-3030R-B Red LEDs on Black Panel
- TSi-3030Y-B Amber LEDs on Black Panel
- TSi-3030B-B Blue LEDs on Black Panel
- TSi-3030R-W Red LEDs on White Panel
- TSi-3030Y-W Amber LEDs on White Panel
- TSi-3030B-W Blue LEDs on White Panel



# Tank Sentry Fluid Level Monitors

## TSi-3535 Series

A larger version of the bargraph display, the 3535's are the best solution where maximum visibility is required. Features large brilliant 20 LED bargraph display, simple push button calibration and included Tank Label Kit.

Dimensions- 2 1/2" x 11 5/8" x 2" deep  
64mm x 296mm x 51mm deep



TSi-3535R-B  
Red LEDs  
on Black Panel



TSi-3535Y-B  
Amber LEDs  
on Black Panel



TSi-3535B-B  
Blue LEDs  
on Black Panel

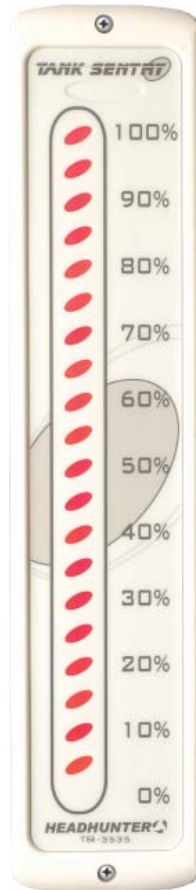

TSi-3535R-W  
Red LEDs  
on White Panel

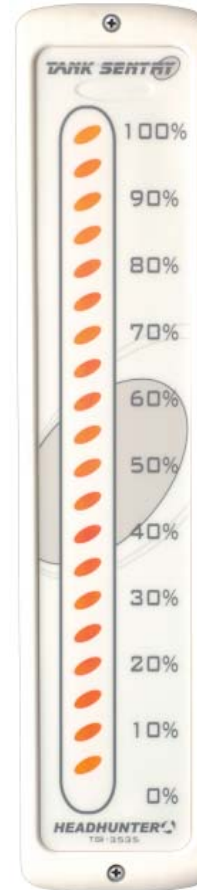

TSi-3535Y-W  
Amber LEDs  
on White Panel

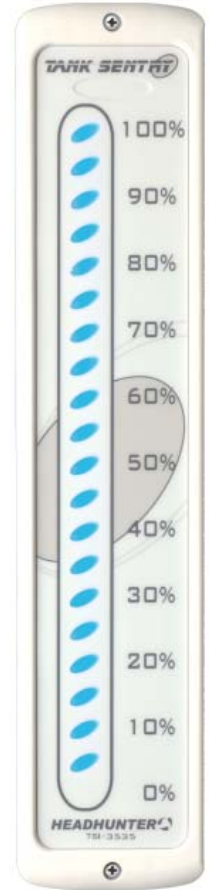

TSi-3535B-W  
Blue LEDs  
on White Panel



*Tank Labels included with TSi-3030 and 3535 Series*

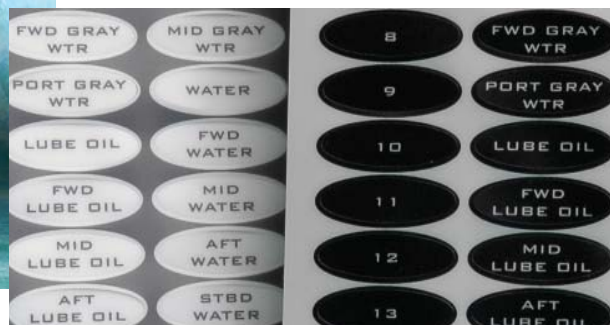

# Typical Network Setup

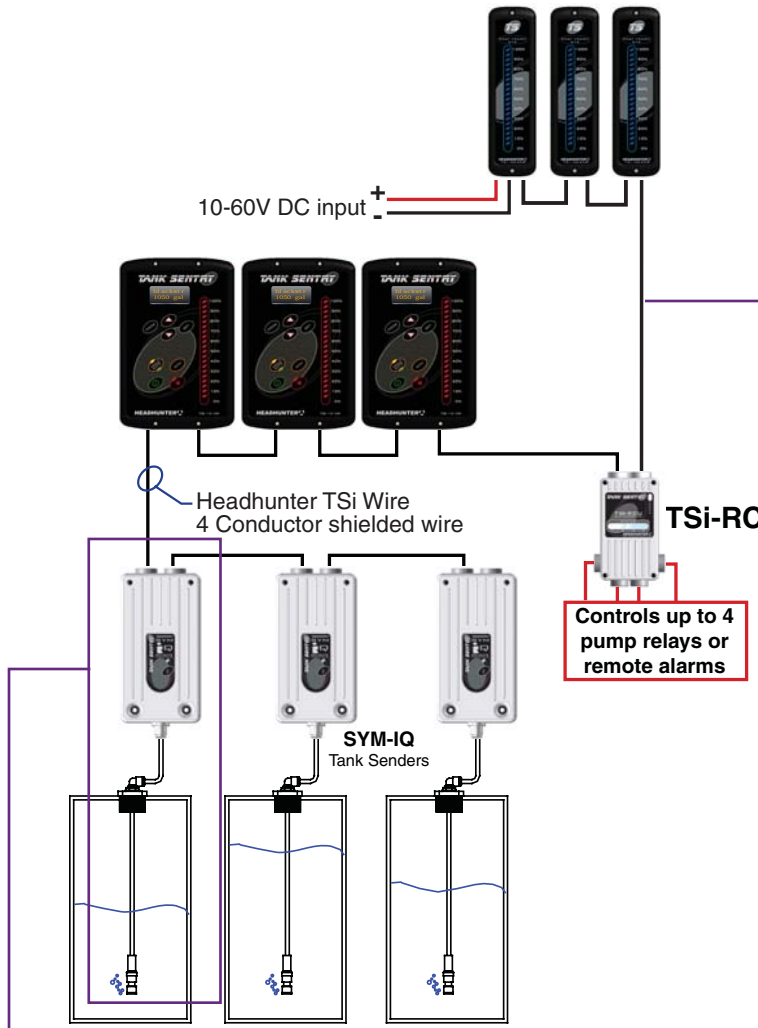

## TSi Network Cable

The Headhunter TSi network cable makes wiring of the TSi system components simple. The specially made 4 conductor cable distributes DC power and provides the half duplex RS-485 twisted pair for digital communication between all the TSi system components.

## TSi-RCU Relay Control Unit



The TSi Relay Control Unit is used to control up to 4 different pump and/or alarm relays. It is controlled by either a TSi 1515 or TSi-2525.

### TSi-RCU

Input Voltage: 10-60 VDC  
 Max Current: 50 mA  
 Dry Contact: 1A@ 10-60V Max  
 Serial Input/ Output: RS485

## TSi-SYM-IQ Kit



The TSi SYM-IQ-Kits monitor the fluid level in the tanks and broadcast the data on the TSi network to any number of control panels. One SYM-IQ-Kit is required for each tank. Each kit includes a SYM-IQ sensor module, 10 ft tubing connection, and tank penetration assembly.

## TSi-SYM-IQ Kit Part Numbering System

part #  
 SYM-IQ\*-KIT-X

### Penetration Assembly

— 1 ¼" MPT SCH 80 PVC  
 SST 1 ¼" MPT 316 Stainless Steel  
 BRS 1 ¼" MPT Brass  
 FLGS 316 Stainless Steel SAE Flange  
 FLGA Aluminum SAE Flange  
 FLGB Brass SAE Flange

### Tank Depth

R Regular depth SYM-IQ 0-132" in H<sub>2</sub>O  
 S Shallow depth SYM-IQ 0-36" in H<sub>2</sub>O

### SYM-IQS

For tanks less than 36" in depth  
 P range: 0-36" in H<sub>2</sub>O  
 Input Voltage: 10-60 VDC  
 Max Current: 420 mA  
 Input/ Output: NMEA2000/RS485

### SYM-IQR

For tanks less more than 36" in depth  
 P range: 0-132" in H<sub>2</sub>O  
 Input Voltage: 10-60 VDC  
 Max Current: 420 mA  
 Input/ Output: NMEA2000/RS485



The Headhunter field service team provides superior dockside installations, and valuable technical support to O.E.M. builders using Headhunter equipment. Intimately involved in new product development, and training of Headhunter sales representatives, the service team's 75 years of combined industry experience, product knowledge, and mechanical/electrical talent add a valuable dimension to the Headhunter experience.



Before, during, and after the sale, customers are continuously reassured by the product knowledge of our international sales team.

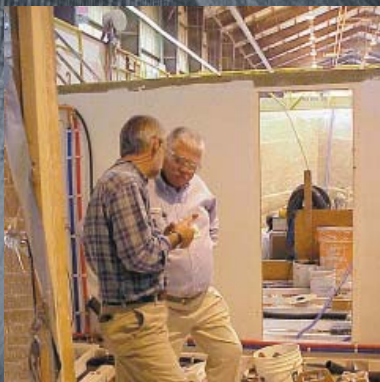

Headhunter personnel work on-site with leading O.E.M. builders reviewing installation details and exchanging new ideas.



## HEADHUNTER INC. QUALITY POLICY

The team at Headhunter is dedicated to providing creative high quality products, solutions and service to our customers. We strive to exceed customer expectations and continuously work to improve our quality management system.



ISO 9001:2000 Certified

I would like to take this opportunity to express my extreme satisfaction in the workmanship of your technicians, Gary and Craig, during the installation of our treatment system on our Feadship. I will recommend their services to other Captains and Engineers I am associated with.

Steve Bertrand  
Chief Engineer  
Emerald K

I just want to let you know that with each boat M&A has written the specification for, we specified as much of your equipment as possible. Our Trawler built at Newcastle marine has your equipment on board. Your toilet system and MSD unit are far superior to vacuum systems used by others, and much less complicated to engineer, and install and maintain. Not to mention your staff is always very helpful and has CAD files available when we need them.

Drew B. Hains  
Naval Architect/Marine Engineer  
Murray and Associates, Inc.  
Fort Lauderdale, Florida

All 10 of our Royal Flush units are still working fine after a year and a half with very few problems. I want to commend your company for supplying such a well designed piece of equipment.

Lon Munsey M/Y Askari  
St. John, US Virgin Is. 00830

I wish to thank you guys for being such an exceptional, highly motivated, and responsive organization.

Donald McCann  
University of Delaware

We will highly recommend your product and look forward to installing this system on all our other vessels.

Wayne R. Hasson  
Aggressors International  
Cayman Islands

# HEADHUNTER