

Moyno AugMentor® Pump Stuffer

Increases Your Pumping Efficiency!

The Moyno AugMentor® electrically driven pump stuffer efficiently handles high viscosity pumped materials, such as cold sausage, in excess of 10,000,000 cps. Its compact design fits a variety of Moyno pump sizes and features 300 series stainless steel construction and a #4 polished finish for maximum corrosion resistance and cleaner sanitary surfaces. The AugMentor disassembles quickly for easy clean-up and inspection.



Always the Right Solution™

Moyno AugMentor®

Key Features and Benefits

The slow-speed, bottom-drive auger gives you low product shear and minimal product smear. The cost-saving, electrically driven design features no obstruction above the stuffer and ensures continuous positive feed. The continuous feed Moyno AugMentor® does not require the frequent maintenance or higher cost of hydraulic feed systems, contributing to lower total cost of ownership.

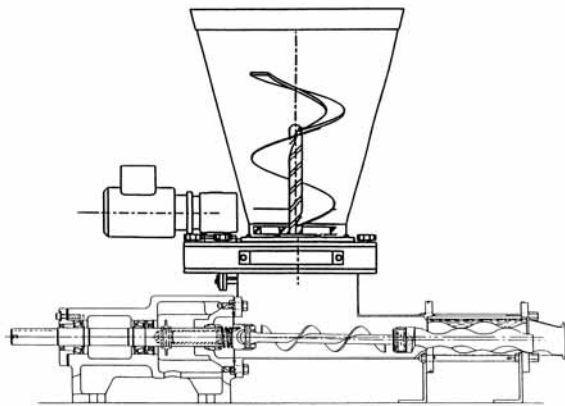

Performance Characteristics & Features

Electrically Driven

- Eliminates expensive hydraulic systems
- Priced lower than traditional equipment

Positive Displacement

- Regulates smooth metered flow or constant pressure system control
 - Efficiently handles high viscosity materials in excess of 10,000,000 cps

Low Maintenance

- Requires no frequent maintenance or costly hydraulic drive systems
- Lower total cost of ownership
- Lower spare parts cost
- Less downtime and lower maintenance costs

Additional Moyno AugMentor Features Include:

- Slow speed auger for low product shear and minimal smearing in meat applications
- Variable speed for matching flow to system requirements
- Variety of pump sizes for a wide range of applications
- High volumetric efficiency for use with smaller pumps
- Overhead filling for easy process operation
- Positive feed and no bridging of pumping material for ensured system operation
- Cost-saving industrial model available for non-sanitary applications

For information about Moyno products or for technical assistance, write or call:

Moyno, Inc.
P.O. Box 960
Springfield, OH 45501-0960
U.S.A.
Telephone:.....1-877-4UMOYNO
Facsimile:937-327-3572
Email: mipinfo@moyno.com

www.moyno.com

Bulletin 126-A



Always the Right Solution™

Note: Information contained herein is subject to change without notice. Before making a final product selection, please contact a Moyno representative.

Your Moyno Authorized Distributor is: