

E41 • T41 Series
Regenerative
Turbine Pumps



- Capacities to 22 GPM
- Heads to 600 Feet
- Temperatures to 300°F



MTH PUMPS

E41 • T41 Series Regenerative Turbine Pumps

MTH E41 • T41 Series

Close-coupled and pedestal mounted regenerative turbine pumps represent the most economical, high performance alternative for low flow (1/2 to 22 GPM) clean fluid applications involving moderate to high pressures (heads to 600 feet). By combining the latest concepts in hydraulic turbine pump design with precision computer controlled manufacturing, the E41/T41 Series pumps deliver high efficiency operation even at low NPSH. Costs are controlled by efficient manufacturing processes and highly optimized pump designs. Maintenance costs are kept to a minimum by combining an easily serviceable design with the use of high quality components to provide long life.

Water Passage Design

MTH masters one of the most critical design considerations for regenerative turbine pumps -- the shaping of water passageways to achieve highest capacity and pressure while minimizing horsepower requirements. By optimizing water passageway cross-sectional profiles for each impeller, MTH has improved both efficiency and pressure in the E41/T41 Series, exceeding the levels realized by previous techniques.

Impeller Profile

One of the most notable improvements in regenerative turbine pump

technology incorporated in E41/T41 Series pumps involves the ability to determine the optimum impeller width and blade length. These factors have a significant effect on the required horsepower versus pressure curve for regenerative turbine pumps. By optimizing these for each E41/T41 Series pump, peak efficiency is improved and "off peak" horsepower requirements are reduced as well.

Impeller Blades

After the most favorable impeller profile has been determined for a particular water passageway cross-section, MTH calculates the number of blades needed to maximize the performance of that pump. Current blade design in E41/T41 Series pumps increases both efficiency and design pressure without the manufacturing difficulties associated with producing contoured blade impellers. State-of-the-art computer controlled machines simplify manufacturing of the various MTH impellers utilized in the E41/T41 Series. The result is a high performance pump providing efficiency characteristics exceeding those of more expensive units.

NPSH Requirements

E41/T41 Series regenerative turbine pumps meet low net positive suction head (NPSH) requirements without efficiency loss. This is achieved by keeping the inlet fluid

velocity low and then gently accelerating to passageway velocities. Special ramps are responsible for an almost shockless fluid entry into the impeller blades and account for the high inlet efficiency in the E41/T41 Series pumps.

E41 Series

Similar to the T31 Series, the E41 takes advantage of our custom manufactured dual face D3 motors that incorporate a 304 stainless steel shaft and heavy-duty bearing. The stainless steel shaft eliminates the necessity of a shaft sleeve, thereby reducing the parts count and simplifying maintenance and servicing procedures. All D3 motors also feature a two-pole 50/60Hz rating, as well as CE Mark approval useful for OEM's with worldwide customers. The three-phase versions of the D3 motors feature a compact TEFC enclosure and a range from 1/3 to 3HP. The single phase D3 motors have an ODP enclosure and a range from 1/3 to 2HP. The E41 is available in horizontal close-coupled and vertical flange mounted configurations only. Please see *Design Features* for more detailed information on both E41 and T41 motor options.

STANDARD MATERIALS

PART	BRONZE FITTED	ALL IRON	ALL BRONZE	316 STAINLESS STEEL
Motor Bracket	Cast Iron ASTM A48	Cast Iron ASTM A48	Bronze ASTM B62	Stainless Steel AISI 316
Cover	Cast Iron ASTM A48	Cast Iron ASTM A48	Bronze ASTM B62	Stainless Steel AISI 316
Impeller	Bronze ASTM B62	Carbon Steel	Bronze ASTM B62	Stainless Steel Waukesha 88
¹ Sleeve/Bushing	Bronze ASTM B16	Stainless Steel AISI 316	Bronze ASTM B16	Stainless Steel AISI 316
"O"Rings	Buna N	Buna N	Buna N	Viton A
Seals	Buna/Ceramic	Buna/Ni-Resist	Buna/Ceramic	Viton/Ceramic
Seats	Buna/Carbon	Buna/Carbon	Buna/Carbon	Viton/Carbon
² Shaft	Stainless Steel AISI 304	Stainless Steel AISI 304	Stainless Steel AISI 304	Stainless Steel AISI 304

¹T41 Only: Sleeves for 3HP and under; Bushings for 5HP and over.

²E41 Only: See *Shaft Sleeves* under *Design Features* for T41 Shaft information.

LIMITATIONS

Discharge Pressure	300 PSI
Seal Pressure*	200 PSI
Suction Pressure (Min)	26" Hg Vac.
Speed	3600 RPM
Temperature	
Standard Construction	-20° F
Ceramic Seal Seat-Water	+230° F
Ni-Resist Seal Seat-Water	+230° F
Silicon Carbide Seal Seat & Internal Seal Flush	+250° F
Cooling Jacket	+300° F
Horsepower	
C3-P3-D3	3 HP
C15-P15	15 HP

*Suction Pressure Plus a Percentage of Differential Pressure

Horizontal Pedestal Mounted

P3 Bearing Frame

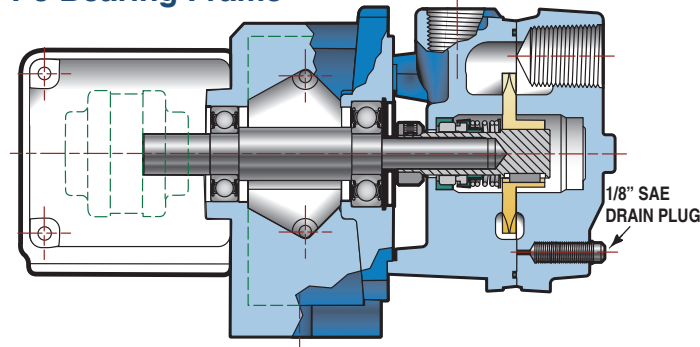

Optional 90° Position

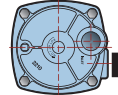

Optional 270° Position

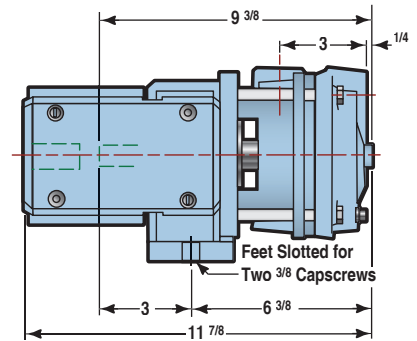
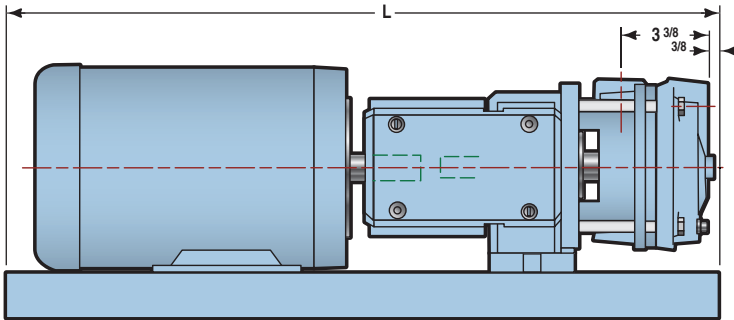
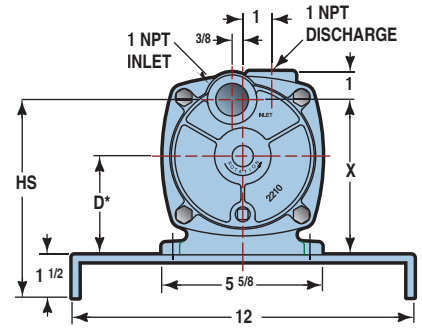
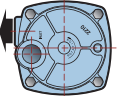

P15 Bearing Frame

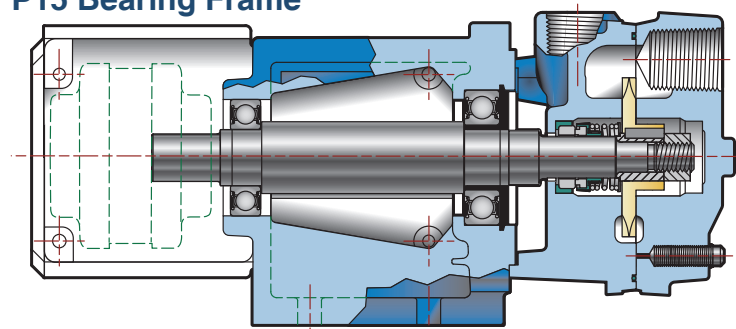

Optional 90° Position

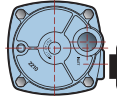

Optional 270° Position

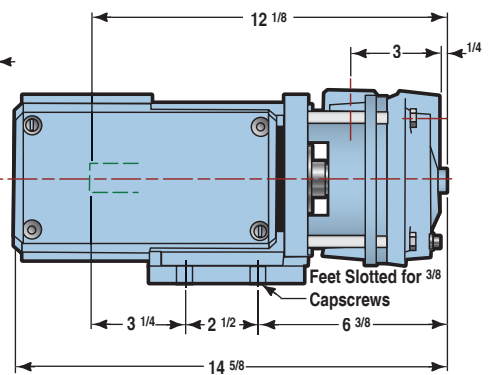
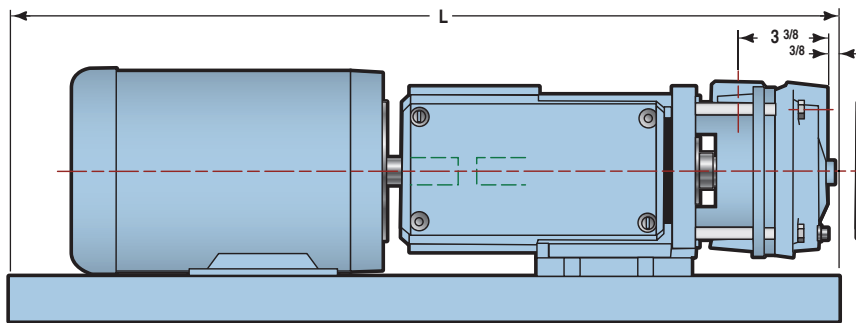
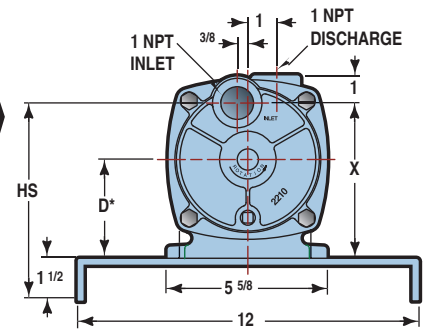
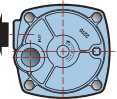

FRAME*	D	X	HS	L(P3)	L(P15)
56	3.50	5.5	7	24	
143T	3.50	5.5	7	24	28
145T	3.50	5.5	7	24	28
182T	4.50	6.5	8	26	30
184T	4.50	6.5	8	26	30
213T	5.25	7.25	8.75		33
215T	5.25	7.25	8.75		33

Note: All Dimensions in inches
Refer to Motor List Price Sheets for frame size and other dimensional data.

Horizontal Close Coupled

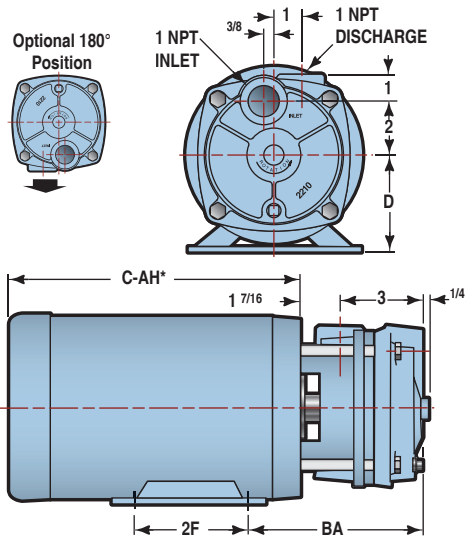
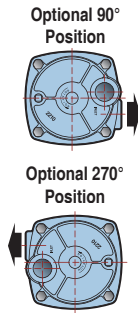
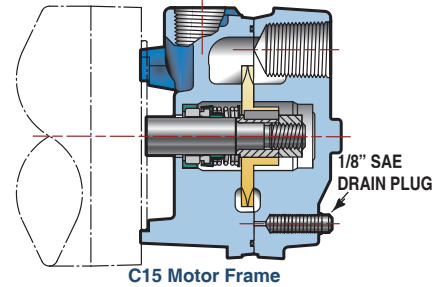
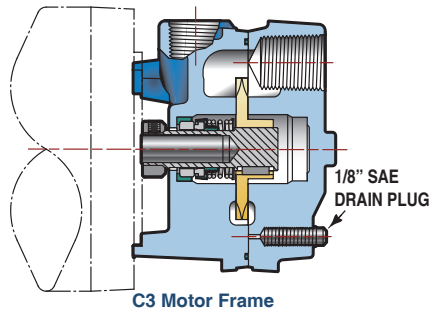

HORSEPOWER	FRAME*	D	BA	2F
.3-7.5 ODP	56C	3.50	6 3/16	3
*	143TCZ	3.50	6 7/16	4
*	143TCZ	3.50	6 7/16	5
*	143TCZ	4.50	7 3/16	4 1/2
*	143TCZ	4.50	7 3/16	5 1/2

Vertical Flange Mounted

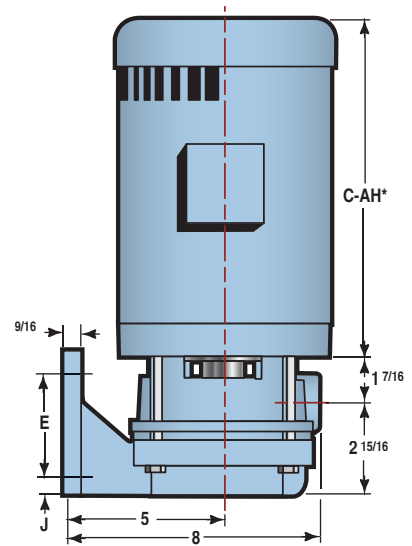
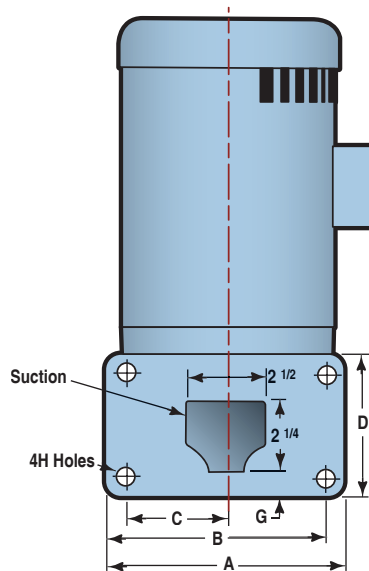
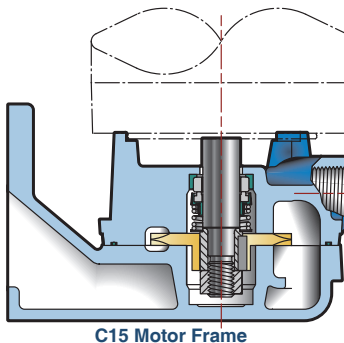
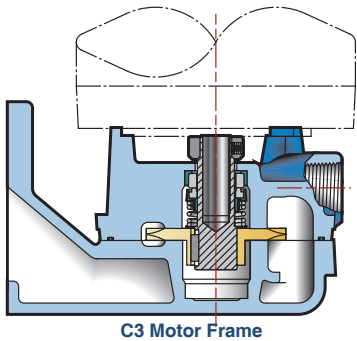

FLANGE STYLE	A	B	C	D	E	G	H	J
AU (7 1/2 x 4 1/2)	7 1/2	6 1/4	3 1/8	4 1/2	3 1/4	3/8	9/16	5/8
DB (4 1/2 x 4 1/2)	4 1/2	3 1/4	1 5/8	4 1/2	3 1/4	3/8	1/2	5/8
FE (7 3/4 x 4 3/4)	7 1/2	6 1/4	3 1/8	4 1/2	3 1/2	3/8	9/16	1/2
PA (6 1/2 x 3 3/4)	6 1/2	5 1/2	2 3/4	3 3/4	2 5/8	3/8	9/16	5/8
SH & BU (6 1/4 x 4)	6 1/4	5	2 1/2	4	2 3/4	3/8	9/16	5/8
SK (6 1/8 x 4 1/8)	6 1/8	5	2 1/2	4 1/8	2 11/16	3/8	9/16	3/4
ST (5 x 5)	5	3 3/4	1 7/8	5	3 3/4	3/8	1/2	5/8
WI (5 x 5)	5	4 1/8	2 1/16	5	4 1/8	3/8	7/16	7/16

*C-AH Dimension -Refer to Motor List Price Sheets for frame size and other dimensional data.
All Dimensions in Inches

Horizontal Close Coupled

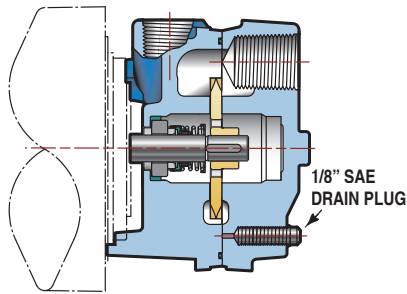

D3 Motor Frame

Optional 180° Position

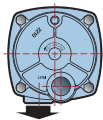

Optional 270° Position

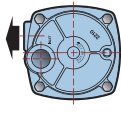

Optional 90° Position

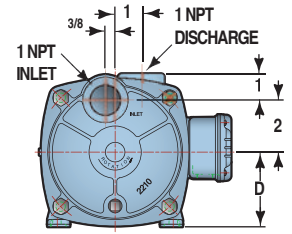
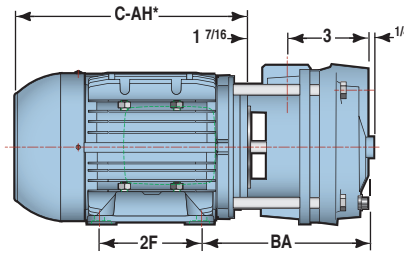
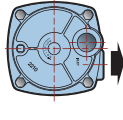

	HORSEPOWER	FRAME	D	BA	2F
E41 3φ	.3 - 1	71	2 13/16	6 11/16	3 9/16
	1.5 - 2	80	3 1/8	6 7/8	3 15/16
	3	90	3 9/16	7 3/16	4 15/16
E41 1φ	.3 - 1.5	48	3	7 1/16	2 9/16
	2	56	3 1/2	7 3/4	3

*C-AH Dimension - Refer to Motor Price Sheet

Vertical Flange Mounted

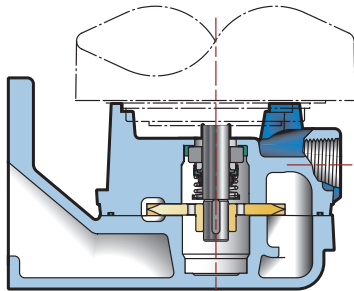

D3 Motor Frame

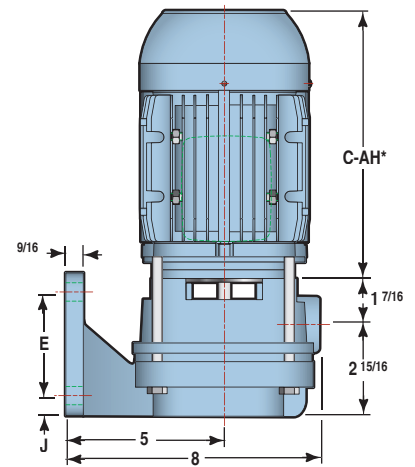
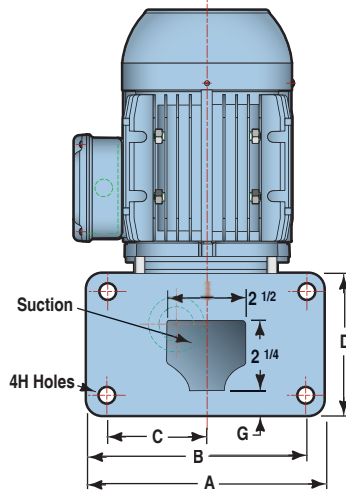

FLANGE STYLE	A	B	C	D	E	G	H	J
AU (7 1/2 x 4 1/2)	7 1/2	6 1/4	3 1/8	4 1/2	3 1/4	3/8	9/16	5/8
DB (4 1/2 x 4 1/2)	4 1/2	3 1/4	1 5/8	4 1/2	3 1/4	3/8	1/2	5/8
FE (7 3/4 x 4 3/4)	7 1/2	6 1/4	3 1/8	4 1/2	3 1/2	3/8	9/16	1/2
PA (6 1/2 x 3 3/4)	6 1/2	5 1/2	2 3/4	3 3/4	2 5/8	3/8	9/16	5/8
SH & BU (6 1/4 x 4)	6 1/4	5	2 1/2	4	2 3/4	3/8	9/16	5/8
SK (6 1/8 x 4 1/8)	6 1/8	5	2 1/2	4 1/8	2 11/16	3/8	9/16	3/4
ST (5 x 5)	5	3 3/4	1 7/8	5	3 3/4	3/8	1/2	5/8
WI (5 x 5)	5	4 1/8	2 1/16	5	4 1/8	3/8	7/16	7/16

*C-AH Dimension - Refer to Motor List Price Sheets for other dimensional data.
All Dimensions in Inches

E41 • T41 SERIES

Design Features

MTH E41 and T41 Series pumps utilize the same major components, and are identical in performance, but utilize different motors. E41 pumps are restricted to close-coupled operation on our own custom designed D3 motors. The D3 motors have a dual C-face with two pole 50//60 Hz ratings as well as an upgraded heavy-duty bearing for extended service life. The three-phase motors have a TEFC IP55 enclosure and power capability from 1/3HP thru 3HP, while the single-phase motors have an ODP IP21 enclosure and range from 1/3HP to 2HP. All D3 motors feature a 304 stainless steel shaft and CE mark approval. T41 pumps can accept most commonly available motors through the use of close or flexible coupling. For wider fluid compatibility, T41 units 3HP and under feature a protective motor shaft sleeve, while motors 5HP and over utilize a corrosion resistant 316 stainless steel shaft. Motors for the T41 Series come in ODP, TEFC, and Explosion-proof enclosures and allow operation at two pole or four pole speeds (3450/2880 or 1750/1450 RPM) ranging from 1/3HP to 3HP (C3/P3 single or three phase) and 5HP to 15HP (C15/P15 three phase only).

Steep Operating Characteristics

Near-constant capacity is maintained over wide variations in pressure. High shut-off pressure overcomes temporary line resistance.

Self-Adjusting Impeller

A hydrodynamic film on each side of the impeller positions it for long life. The impeller exerts no thrust load on bearings. Pump operates equally well in a vertical or horizontal position.

Mechanical Seals

Bronze fitted pumps have Buna N elastomers, high temperature carbon, and ceramic seats for best hot water service. Optional seats and materials are also available.

300# Case Working Pressure

Rigid structure is designed for maximum casing strength.

100% Tested

Every pump is fully tested to verify performance prior to shipment.



Volatile Fluid Handling

Turbine impeller handles vapors in excess of 20% by volume, minimizing the possibility of vapor locks.

"O" Ring Gaskets

"O" ring seals are used throughout the E41/T41 Series pumps to assure sealing and ease of service.

Shaft Sleeve

T41 pumps with motors 3HP and under utilize a protective shaft sleeve of an appropriate metallurgy according to the *Standard Materials* table. Motors 5HP and over have a 316 stainless steel shaft with an impeller bushing as listed under *Standard Materials*. E41 pumps do not utilize a shaft sleeve due to the use of a standard 304 stainless steel motor shaft.

Water Flinger

A water flinger provides added protection to ball bearings in the event of seal leakage.

Simple Construction

E41/T41 Series pumps contain only three major components, allowing for easy service.

End Suction • Top Discharge

E41/T41 Series pumps fit into small spaces easily. Discharge can be rotated to 90 degree, 180 degree and 270 degree positions.

Best Efficiency

New pump design optimizes efficiency for each size.

Non-Cavitating

E41/T41 series pumps may be operated under adverse inlet conditions without audible or measurable cavitation.

Low NPSH

New inlet design provides superior fluid handling ability at low head inlet conditions.

Optional Features

CONSTRUCTION MATERIALS.

Bronze fitted, all iron, all bronze and 316 stainless steel are available as stock materials. Consult the factory for special materials.

BEARING PEDESTALS.

All T41 models can be pedestal mounted for flexible drive.

VERTICAL FLANGE MOUNT.

All sizes are available as vertical mount units, with eight standard flange types available.

INTERNAL FLUSH LINE. Internal passageway flushes mechanical seal seats. When used with the optional silicon carbide seal seat, allows operation in water up to 250°F.

INLET STRAINER. A 90° suction strainer with a replaceable screen is available for installation in the suction line to help prevent foreign materials from entering the pump. A cap at the bottom of the strainer can be easily and quickly removed for screen cleaning or replacement.

Optional Features (Continued)

SEALLESS CANNED VERSION. For difficult to seal applications

300°F SEAL COOLING JACKET. Extends maximum working temperature of the pump to 300°F or higher. Ports are provided for an external fluid cooling source. The cooling jacket adds 2 1/2" to the standard pump length and is available for 1/3HP up to 3HP T41 Motors. Consult the factory for details.

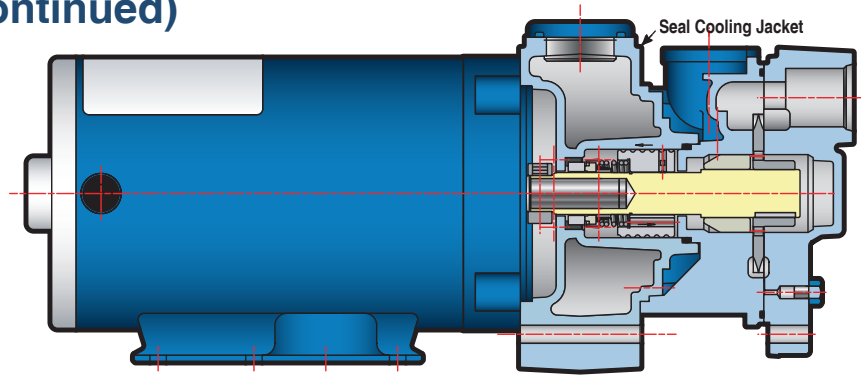

E41 • T41 SERIES

Engineering Specification

Horizontal Close Coupled

The contractor shall furnish (and install as shown on the plans) an MTH E41/T41 Series horizontal close coupled regenerative turbine type pump model _____ size 1" by 1" of (BRONZE FITTED) (ALL IRON) (ALL BRONZE) (316 STAINLESS STEEL) construction. Each pump shall have a capacity of _____ GPM when operating at a total head of _____ feet. Suction pressure will be _____ feet with a liquid temperature of _____ degrees F.

The pump is to be furnished with a mechanical seal with stainless steel metal parts, Buna elastomers, ceramic seat and carbon washer. A stainless steel shaft or a shaft sleeve shall be furnished in pumps up to three horsepower and a 316 stainless steel shaft in pumps five horsepower and larger.

The pump casing shall be vertically split two piece, end suction and (TOP DISCHARGE) (90° DISCHARGE) (180° DISCHARGE) (270° DISCHARGE) with water passageways accurately machined into each piece. The impeller shall be hydraulically self centering and no external adjustment shall be necessary.

The pump shall be close coupled to a standard NEMA "C" face _____ HP _____ phase _____ Hertz _____ voltage _____ RPM horizontal (OPEN DRIPPROOF) (TOTALLY ENCLOSED) (EXPLOSION PROOF) motor. The motor shall be sized to prevent overloading at the highest head condition listed in the specifications.

Vertical Flange Mount

The contractor shall furnish (and install as shown on the plans) an MTH E41/T41 Series vertical close coupled flange mount regenerative

turbine type pump model _____ of (BRONZE FITTED) (ALL IRON) (ALL BRONZE) construction. Each pump shall have a capacity of _____ GPM when operating at a total head of _____ feet with a style _____ suction flange and a 1" discharge. Suction pressure will be _____ feet with a liquid temperature of _____ degrees F.

The pump is to be furnished with a mechanical seal with stainless steel metal parts, Buna elastomers, ceramic seat and carbon washer. A stainless steel shaft or a shaft sleeve shall be furnished in pumps up to three horsepower and a 316 stainless steel shaft in pumps five horsepower and larger.

The pump casing shall be vertically split two piece design with water passageways accurately machined into each piece. The impeller shall be hydraulically self centering and no external adjustment shall be necessary.

The pump shall be close coupled to a standard NEMA "C" face _____ HP _____ phase _____ Hertz _____ voltage _____ RPM horizontal (OPEN DRIPPROOF) (TOTALLY ENCLOSED) (EXPLOSION PROOF) motor. The motor shall be sized to prevent overloading at the highest head condition listed in the specifications.

Horizontal Pedestal Mount

The contractor shall furnish (and install as shown on the plans) an MTH T41 Series horizontal pedestal mount regenerative turbine type pump model _____ size 1" by 1" of (BRONZE FITTED) (ALL IRON) (ALL BRONZE) (316 STAINLESS STEEL) construction. Each pump shall have a capacity of _____ GPM

when operating at a total head of _____ feet. Suction pressure will be _____ feet with a liquid temperature of _____ degrees F.

The pump is to be furnished with a mechanical seal with stainless steel metal parts, Buna elastomers, ceramic seat and carbon washer. A stainless steel shaft shall be furnished in pumps up to three horsepower and a 316 stainless steel shaft in pumps five horsepower and larger.

The pump casing shall be vertically split two piece, end suction and (TOP DISCHARGE) (90° DISCHARGE) (270° DISCHARGE) with water passageways accurately machined into each piece. The impeller shall be hydraulically self centering and no external adjustment shall be necessary.

The pump shall be mounted on a bearing pedestal with sealed, grease lubricated ball bearings having a two year minimum design life under a maximum pump differential pressure of 300 PSI. The pump shaft shall be of 416 stainless steel construction for up to three horsepower driver and of 316 stainless steel construction for five horsepower and larger driver.

Pump and motor shall be mounted on a common steel baseplate (WITH CAST IRON DRIP PAN). The pump is to be flexible coupled with aluminum coupling guard to a standard horizontal NEMA _____ HP _____ phase _____ Hertz _____ voltage _____ RPM horizontal (OPEN DRIPPROOF) (TOTALLY ENCLOSED) (EXPLOSION PROOF) motor. The motor shall be sized to prevent overloading at the highest head condition listed in the specifications.

Coupling alignment shall be checked after installation.

Performance Curve

E41 • T41 SERIES

3450 RPM

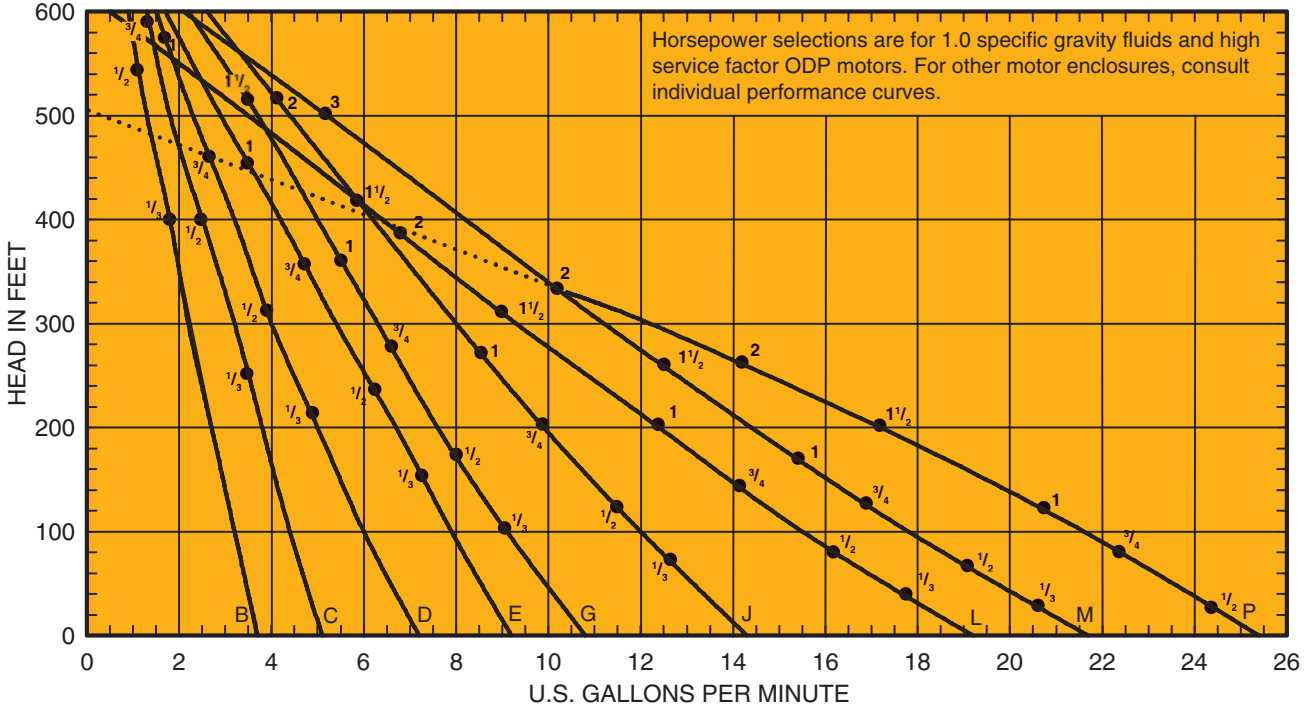

E41 • T41 SERIES

2880 RPM

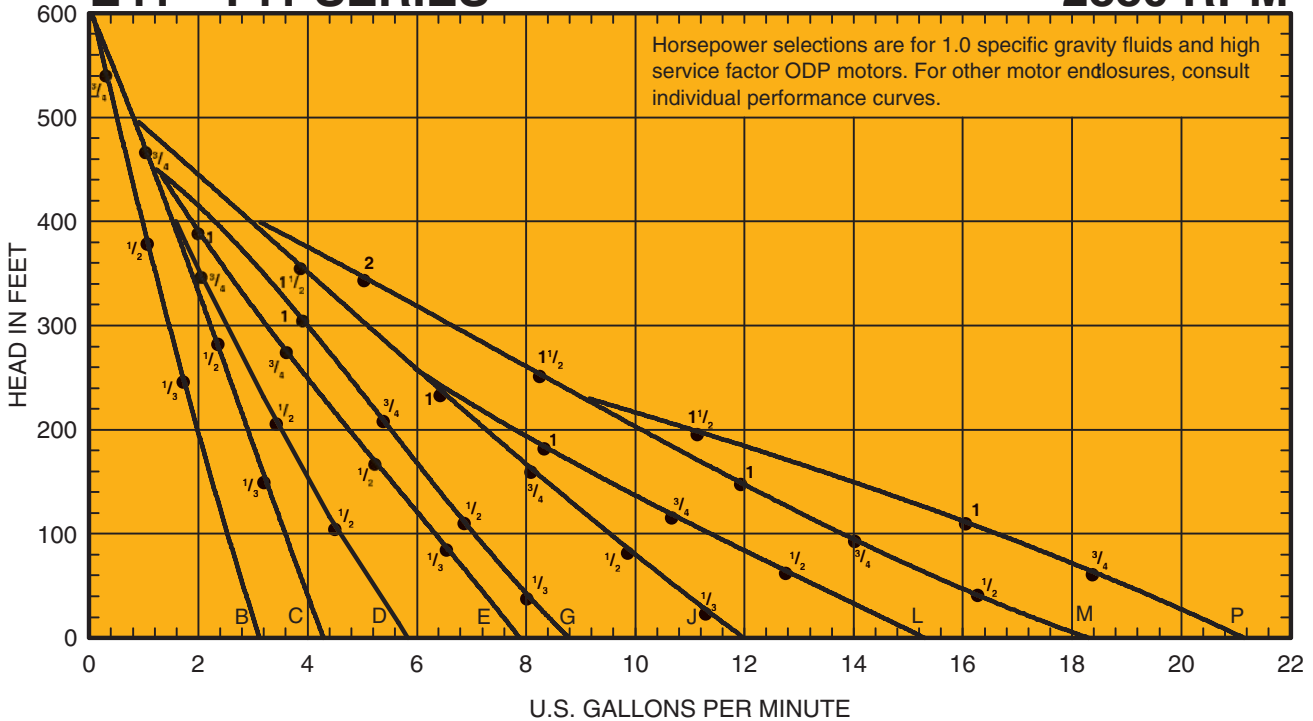

MTH PUMPS

401 West Main Street • Plano, IL 60545-1436
 Phone: 630-552-4115 • Fax: 630-552-3688
 Email: SALES@MTHPUMPS.COM
<http://WWW.MTHPUMPS.COM>