

4" x 4" Automatic Dry Priming Pump

Applications:

- Construction Dewatering
- Sewage Bypass
- Flood Drainage
- Mining/Quarries
- Municipal
- General Industrial



Member of
Hydraulic
INDUSTRY

The PrimeRite™ is the perfect pump for contractors, pump rental companies, mining operators and general industrial or municipal use. This robust, rugged and reliable, automatic dry priming, trash handling pump is designed and built for the most demanding environments – where pumps operate unattended; 24/7. The CT004 is capable of flow rates up to 1320 GPM, total dynamic heads to 157' and solids handling to 1 1/2".

The PrimeRite's™ oil-filled bearing box and a mechanical seal in an oil bath enable it to run dry all day long; making it the right choice for handling inconsistent flows found in sewage bypass pumping and job site dewatering. Its open impeller handles sewage or normal job site debris with ease. Units are completely self contained in either skid or trailer configurations with integral lifting bail, tie downs and fuel tank. Want the Best – Buy from the Best.

FEATURES

- Flows up to 1320 GPM
- Heads up to 157' TDH
- Passes 1 1/2" solids
- Primes and reprimed automatically
- Indefinite run dry capability
- Stainless steel venturi priming system
- Compressor is water cooled and oil lubricated
- Vacuum lift to 28'
 - Vacuum gauge
- Lockable fuel cap
- Forklift slots (skid models)
- Integral 78 gallon fuel tank with gauge
- Skid or optional trailer mounted
 - Torsion bar axle
 - DOT light kit available*
 - Electric or surge brakes available*
 - Front and rear stabilizing jacks
 - 3" Lunette ring for Pintle Hitch - Other options available
- Heavy-duty truck tie downs
- Lifting bail
- Mechanical seal and bearing box oil-level sight glasses
 - *Required for highway use
- Discharge check valve
- Engines - Caterpillar, Perkins, John Deere and Deutz available
 - Flexible flywheel coupling
 - Engine control panel with tach, hour meter, overspeed protection and safety shutdowns
- Volute drain
- 4" ANSI Pattern Flanges – Suction and discharge
- Optional Bauer-type fittings shown
 - Other fittings available
- Optional float-activated, Auto Start/Stop controls

MWI Corporation • 201 North Federal Highway • Deerfield Beach • FL 33441 USA
Tel: (954) 426-1500 • Fax: (954) 426-1582 • Web: www.mwicorp.com

CT004 PERFORMANCE

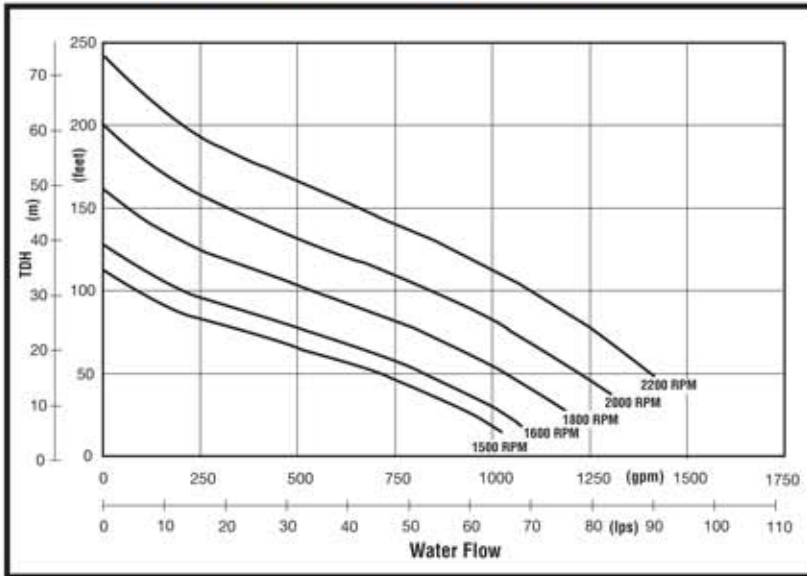

The PrimeRite™ pump performance is based on clean water at sea level, with 10' suction lift. With the standard diesel engine, the CT004 will perform up to 1800 RPM.

Materials & Specifications

- **Impeller and Wear Plates:** Hardened, high-chromium, wear-resistant cast iron – KmTBCr26 with Brinell hardness > 558
- **Pump casing:** High-grade, spheroidal graphite (ductile) cast iron
- **Shaft:** Heat treated 1045 steel
- **Engine:** Diesel engine rated at 30 net continuous HP at 1800 RPM
- **Compressor:** Belt-driven, oil lubricated and water cooled or engine mounted (optional with some models)
- **Priming assembly:** Stainless steel venturi
- **Control Panel:** Tach and hour meter, including shutdowns for: low oil pressure, high coolant temperature and overspeed
- **Discharge non-return valve:** Val-Matic Swing Flex check valve
- **Mechanical seal:** Stainless steel with silicon carbide faces
- **Weight of trailer mounted unit:** 3500 lbs (dry)

PHYSICAL DATA

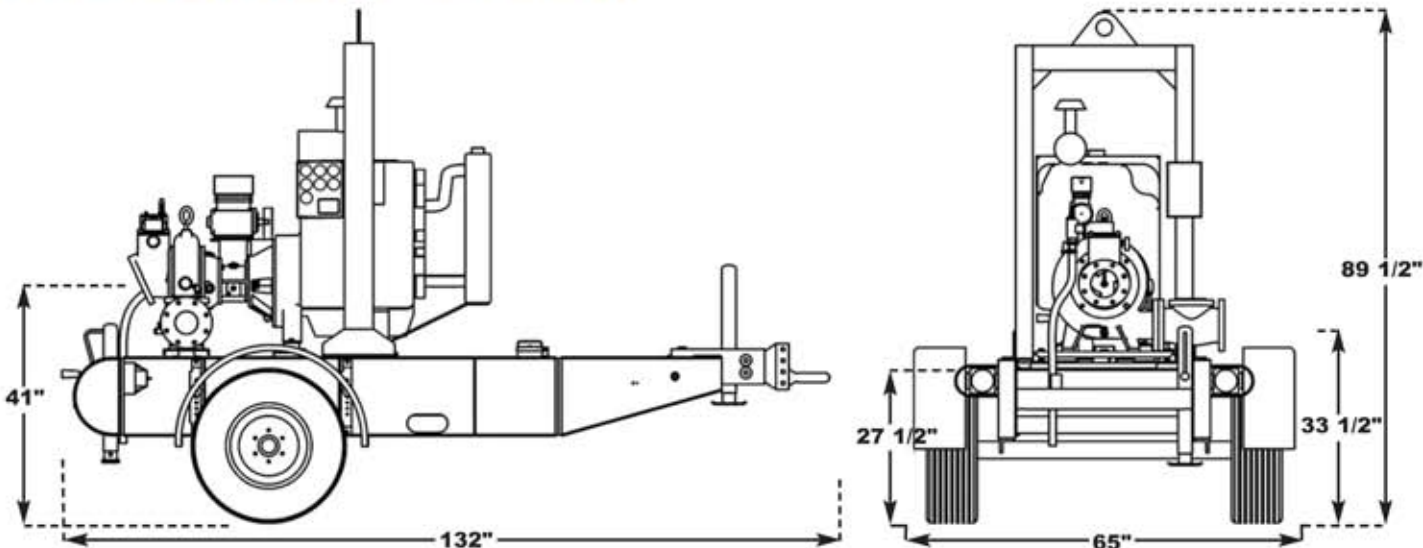

MWI Corporation • 201 North Federal Highway • Deerfield Beach • FL 33441 USA
Tel: (954) 426-1500 • Fax: (954) 426-1582 • Web: www.mwicorp.com