



RotoFlo™ RWP006

6" Wellpoint Pump

APPLICATIONS:

Construction

Wellpoint

Sock Dewatering

Remediation

Recharge

Multiple Fluid Transfer

Capabilities

The RotoFlo™ is the perfect pump for construction dewatering. Whether you are using a wellpoint or sock system, the air/water handling capabilities of the RotoFlo™ will work on your site trouble free - and with minimum use of fuel. The simple design eliminates the need for complicated vacuum priming, floats and air/water separation systems known for failures.

Downtime is reduced thanks to the Maintenance In Place design, which allows for on-site repairs with no special tools or requirements. The 100% bolt-together design adds flexibility to your operations. A few simple steps will convert your skid into a full DOT or off-road trailer. MWI offers a complete line of accessories for your wellpoint and construction dewatering needs. including swing-joints, header pipe, wellpoints and jetting equipment.

FEATURES

- High performance (450 GPM & 210 FT. TDH)
- Dry running mechanical seals
- Pumps slurries and brackish waters
- Choice of diesel engines or electric motors
- Integral fuel tank with gauge and lockable fuel cap
- Fuel efficient
- Pulsation free design
- Skid or trailer available
- Rotary lobes, wear plates and seals are easily replaceable on site
- Silent enclosures available (67dB @ 23 Feet) for residential areas



*Required for highway use

PERFORMANCE

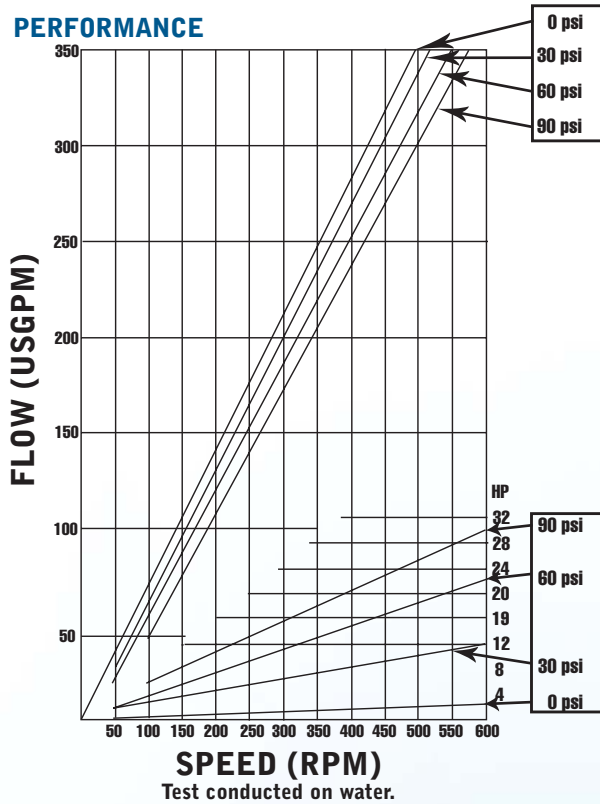

MATERIALS & SPECIFICATIONS

- Pump casing: Cast iron. Special hardened ductile cast iron and stainless steel are available.
- Rotary lobes: Standard cast iron body encapsulated with wear and age resistant Buna. Other coating materials available.
- Wear liner: Stainless steel
- Shaft: Stainless steel
- Discharge: 6" Flapper check valve
- Mechanical seal: Oil bath, dry running seal, with abrasion resistant silicon carbide faces.
- Diesel Engine Panel: Tach and hour meter, including shutdowns for: low oil pressure, high coolant temperature and overspeed
- Electric Panel: Full or reduced starter. Variable frequency drive (VFD) optional.
- Weight: 2850 lbs

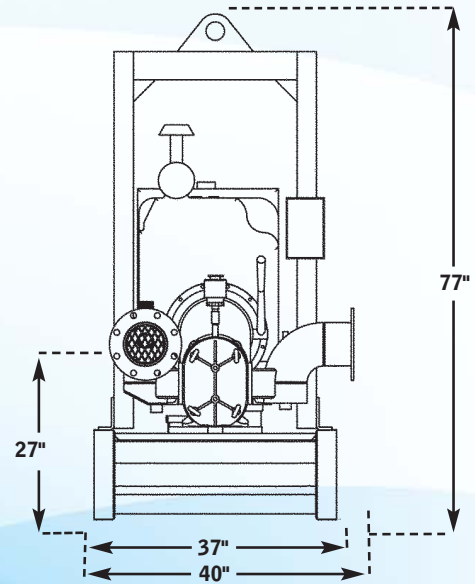
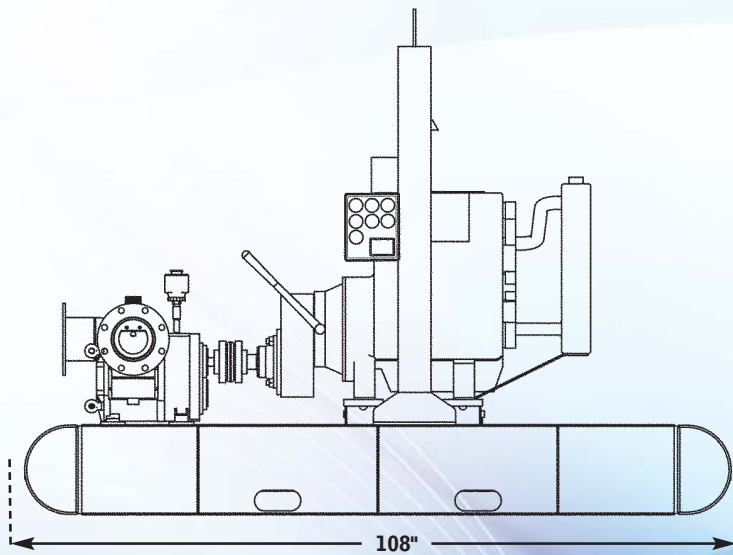

Model	Size	Max. Capacity (GPM)	Max CFM	Max Head (FT)
RWP006	6"/6"	540	72	210



Ask us about the Silent Partner™ for your RotoFlo™ pump - a great addition for quiet pump operation.



MWI Corp. RotoFlo is a registered trademark. Copyright 2008. All rights reserved. Designs and specifications may change due to continual improvement of our products. P0808

Moving Water Worldwide - Reliably and Efficiently

201 N. Federal Highway Deerfield Beach, Florida 33441 USA
 Phone: (954) 426-1500 Fax: (954) 426-1582 E-mail: info@mwicorp.com www.mwicorp.com