

High Head Filtered Effluent Pumps

1/2, 3/4, 1 and 1 1/2 HP
8, 12, 20, 25, 30 and 35 GPM
4" Diameter Submersibles



MYERS HIGH HEAD FILTERED EFFLUENT PUMPS ARE DESIGNED SPECIFICALLY FOR HIGH PRESSURE APPLICATIONS. The high performance, high head pumps are proven to be cost effective solutions for pumping filtered effluent from processed wastewater systems. For more details, contact your Myers distributor or Myers Ohio sales office at 419/289-1144. (For domestic use only.)

ADVANTAGES BY DESIGN

- High pressure capacity.
- Corrosion resistant design for long life.
- UL and CSA listed.
(Listings pending on 25, 30 and 35 GPM units.)
- Dependable field proven motor.
 - Stainless steel construction
 - Built-in overload and electric surge protection
 - Replaceable 10' jacketed power cord
 - Hermetically sealed windings
 - Continuous duty rating
- Frequent cycling capabilities.
 - 1/2 and 3/4 HP - 300 starts/24 hours
 - 1 and 1 1/2 HP - 100 starts/24 hours
- Powerful, yet lightweight.
- Easy handling and installation.

PRODUCT CAPABILITIES

Capacities To	50 GPM
Heads To	480 Feet
Max. Spherical Solids	1/16" Diameter
Liquids Handling	Filtered effluent
Max. Liquid Temp.	122° F
Motor Electrical Data	1/2 HP 115 volts, 1 ph 1/2 to 1-1/2 HP 230 volts, 1 ph 60 Hz, 3450 RPM
Motor Rating	Continuous duty
Max. Motor Starts/24 Hours	300 (1/2 and 3/4 HP) 100 (1 and 1-1/2 HP)
Third Party Listings	UL, CSA
Specific Gravity	.9 - 1.1
Viscosity	28 - 35 SSU
Discharge, NPT	1-1/4" (8, 12, 20, and 30 GPM) 2" (25 and 35 GPM)

Corrosion Resistant Pump Construction

Shell	300 Series SST
Shaft and Coupling	300 Series SST
Suction Bowl - 8, 12, 20, 30 GPM - 25, 35 GPM	Chemically Resistant Reinforced Nylon Lead Free Brass
Discharge Bowl - 8, 12, 20, 30 GPM - 25, 35 GPM	Corrosion Resistant Reinforced Polycarbonate Lead-free Brass
Staging - 8, 12, 20 GPM - 25, 30, 35 GPM	Premier Teflon® Reinforced Polyester Reinforced Polycarbonate
Built-in Check Valve (8, 12, 20 GPM)	Premier Teflon Reinforced Polyester
Thrust Washers	Phenolic
Fasteners	300 Series SST
Impeller Wear Ring	300 Series SST

Corrosion Resistant Motor Construction

Shell and End Caps	SST
Spline Shaft	SST
Electrical Protection	Built-in Overload and Surge Arrestor
Third Party Listings	UL, CSA
Replaceable Motor Lead Wire Assembly	14-3 Jacketed Type SJOW-A UL and CSA Recognized
Windings	Hermetically Sealed
Motor Mounting	NEMA

WHERE INNOVATION MEETS TRADITION

Myers[®]
Pentair Pump Group

PUMP SELECTION CHART

(Ft.)	Capacity (GPM)																	
	2NFL51-8E	2NFL52-8E	2NFL72-8E	2NFL102-8E	2NFL51-12E	2NFL52-12E	2NFL72-12E	2NFL102-12E	2NFL51-20E	2NFL52-20E	2NFL72-20E	2NFL102-20E	2NFL152-20E	2NFL51-30E	J1025BE	J1525BE	J1035BE	J1535BE
50	13	13	13	13	18	18	18	18	24	24	26	28		34	38	42	48	
60	13	13	13	13	18	18	18	18	22	22	25	27		30	36	40	44	52
70	13	13	13	13	17	17	17	17	21	21	24	26	28	27	35	39	37	47
80	13	13	13	13	17	17	17	18	19	19	23	25	27	23	33	38		44
90	12	12	13	13	16	16	18	18	18	18	22	25	27	18	32	37		41
100	12	12	13	13	16	16	17	18			21	24	26	12	30	35		37
120	12	12	13	13	15	15	17	17			19	23	25		27	33		
140	11	11	12	13	13	13	16	17			17	21	25		30			
160	11	11	11	12	12	12	15	16			19	19	23		26			
180	10	10	11	12			14	15			17	17	22					
200	9	9	11	12			13	15			16	16	22					
220	8	8	10	11			12	14					20					
240	7	7	9	11			11	13					19					
260	5	5	9	11				12					17					
280			8	10				11					16					
300			7	10				10					13					
320			6	9									10					
340			5	9														
360			4	8														
380				7														
400				6														
420				5														
440				4														
460																		
480																		
500																		
Max. Head (valve closed)	290' 125 psi	290' 125 psi	390' 169 psi	480' 208 psi	240' 104 psi	310' 134 psi	380' 165 psi	130' 56 psi	190' 82 psi	260' 112 psi	350' 151 psi	115' 50 psi	200' 87 psi	270' 117 psi	110' 48 psi	160' 69 psi		

High Head Filtered Effluent Pumps

1/2, 3/4, 1 and 1 1/2 HP
 8, 12, 20, 25, and 35 GPM
 4" Diameter Submersibles

8 GPM

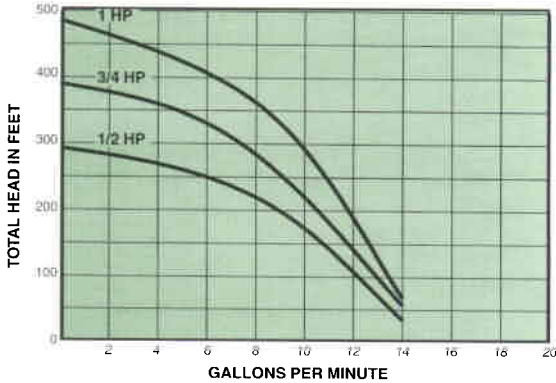

HP	Voltage	Pump Model
1/2	115	2NFL51-8E
1/2	230	2NFL52-8E
3/4	230	2NFL72-8E
1	230	2NFL102-8E

12 GPM

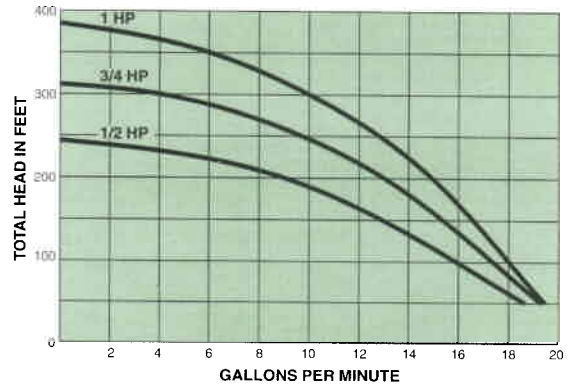

HP	Voltage	Pump Model
1/2	115	2NFL51-12E
1/2	230	2NFL52-12E
3/4	230	2NFL72-12E
1	230	2NFL102-12E

20 GPM

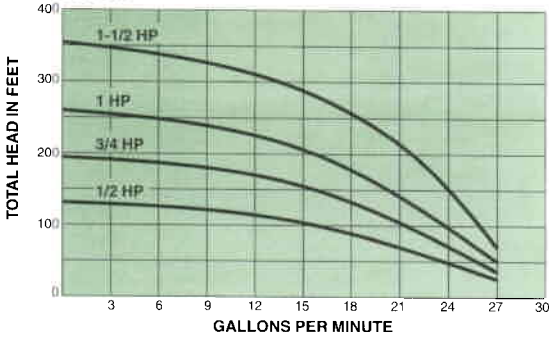

HP	Voltage	Pump Model
1/2	115	2NFL51-20E
1/2	230	2NFL52-20E
3/4	230	2NFL72-20E
1	230	2NFL102-20E
1 1/2	230	2NFL152-20E

25 GPM

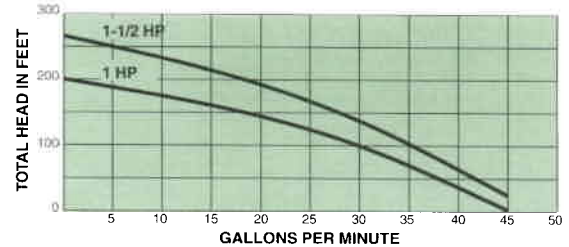

HP	Voltage	Pump Model
1	230	J1025BE
1 1/2	230	J1525BE

30 GPM

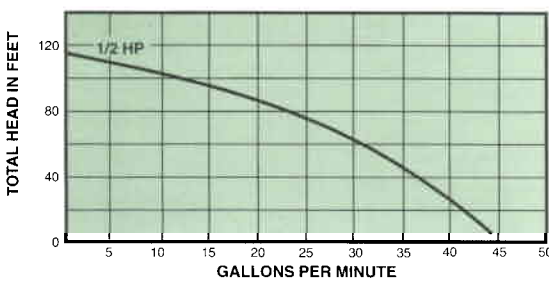

HP	Voltage	Pump Model
1/2	230	2NFL51-30E

35 GPM

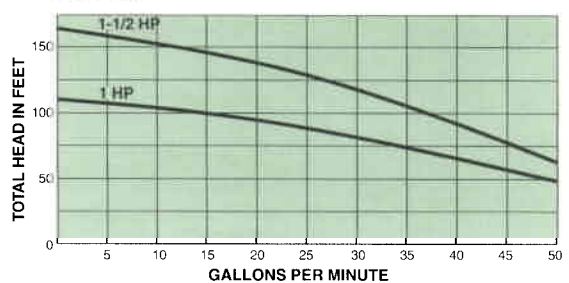

HP	Voltage	Pump Model
1	230	J1035BE
1 1/2	230	J1535BE

High Head Filtered Effluent Pumps

1/2, 3/4, 1 and 1 1/2 HP
8, 12, 20, 25, 30 and 35 GPM
4" Diameter Submersibles

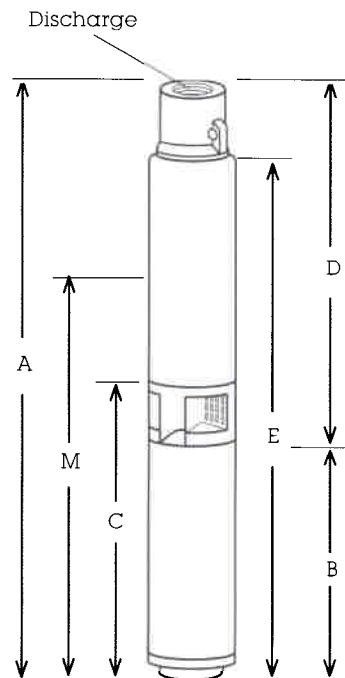

SUBMERSIBLE PUMP DIMENSIONS

Pump Model	A	B	C	D	E	M	Discharge
2NFL51-8E	24 1/4	9 1/2	12	14 3/4	20 3/4	19 1/2	1 1/4"
2NFL52-8E	24 1/4	9 1/2	12	14 3/4	20 3/4	19 1/2	1 1/4"
2NFL72-8E	26	10 1/2	13	15 1/2	22 1/2	21	1 1/4"
2NFL102-8E	29 3/4	11 3/4	14 1/4	18	26 1/4	23	1 1/4"
2NFL51-12E	23 1/4	9 1/2	12	13 3/4	19 3/4	20	1 1/4"
2NFL52-12E	23 1/4	9 1/2	12	13 3/4	19 3/4	20	1 1/4"
2NFL72-12E	26 1/4	10 1/2	13	15 3/4	22 3/4	21 1/2	1 1/4"
2NFL102-12E	29	11 3/4	14 1/4	17 1/4	25 1/2	23 1/2	1 1/4"
2NFL51-20E	23 1/2	9 1/2	12	14	20	20	1 1/4"
2NFL52-20E	23 1/2	9 1/2	12	14	20	20	1 1/4"
2NFL72-20E	25 1/2	10 1/2	13	15	22	22	1 1/4"
2NFL102-20E	27 1/2	11 3/4	14 1/4	15 3/4	24	26	1 1/4"
2NFL152-20E	34 1/4	15 1/4	17 3/4	19	30 3/4	27	1 1/4"
2NFL51-30E	23 1/2	9 1/2	12	14	20 1/2	20	1 1/4"
J1025BE	29 3/4	11 3/4	14 1/4	18	26 1/4	27	2"
J1525BE	36 1/4	15 1/4	17 3/4	21	32 3/4	29	2"
J1035BE	26 1/4	11 3/4	14 1/4	14 1/2	22 3/4	27	2"
J1535BE	33 3/4	15 1/4	17 3/4	18 1/2	30 1/4	29	2"

A = Overall Pump Height

B = Motor Height

C = Intake Height

Discharge = Discharge Size (NPT)

NOTE: All dimensions are in inches

D = Pump End Height

E = Bypass Orifice Height

M = Minimum Liquid Level

TECHNICAL SPECIFICATIONS

Model	HP	Volt	GPM	Max Amps	Locked Rotor Amp	Winding Resistance (OHMS)	Max Fuse/CB	AWG Copper Wire Size Selection Chart*					
								Max. Distance from Power Supply to Pump (Feet)					
								14	12	10	8	6	4
2NFL51-8E	1/2	115	8	12.0	64	1.0 - 1.3	30	100	160	250	390	620	960
2NFL52-8E	1/2	230	8	6.0	32	4.2 - 5.2	15	400	650	1020	1610	2510	3880
2NFL72-8E	3/4	230	8	8.0	41	3.0 - 3.6	20	300	480	760	1200	1870	2890
2NFL102-8E	1	230	8	9.8	49	2.2 - 2.7	25	250	400	630	990	1540	2380
2NFL51-12E	1/2	115	12	12.0	64	1.0 - 1.3	30	100	160	250	390	620	960
2NFL52-12E	1/2	230	12	6.0	32	4.2 - 5.2	15	400	650	1020	1610	2510	3880
2NFL72-12E	3/4	230	12	8.0	41	3.0 - 3.6	20	300	480	760	1200	1870	2890
2NFL102-12E	1	230	12	9.8	49	2.2 - 2.7	25	250	400	630	990	1540	2380
2NFL51-20E	1/2	115	20	12.0	64	1.0 - 1.3	30	100	160	250	390	620	960
2NFL52-20E	1/2	230	20	6.0	32	4.2 - 5.2	15	400	650	1020	1610	2510	3880
2NFL72-20E	3/4	230	20	8.0	41	3.0 - 3.6	20	300	480	760	1200	1870	2890
2NFL102-20E	1	230	20	9.8	49	2.2 - 2.7	25	250	400	630	990	1540	2380
2NFL152-20E	1 1/2	230	20	13.1	57	1.5 - 1.9	35	190	310	480	770	1200	1870
2NFL51-30E	1/2	115	30	12.0	64	1.0 - 1.3	30	100	160	250	390	620	960
J1025BE	1	230	25	9.8	49	2.2 - 2.7	25	250	400	630	990	1540	2380
J1525BE	1 1/2	230	25	13.1	57	1.5 - 1.9	35	190	310	480	770	1200	1870
J1035BE	1	230	35	9.8	49	2.2 - 2.7	25	250	400	630	990	1540	2380
J1535BE	1 1/2	230	35	13.1	57	1.5 - 1.9	35	190	310	480	770	1200	1870

*Maximum length of copper wire in feet. For aluminum wire, select one size larger (i.e. No. 8 aluminum for No. 10 copper)