

# 4MSW/4MSWH/6MSW SERIES

## 4" & 6" Non-Clog Wastewater Pumps

### SPECIFICATIONS

Applications	Sewage, High-Capacity Sump, Effluent	
Capacities	1,000 GPM	3,777 LPM
Shut-off Head	100'	30.5 m
Solids Handling		
MSW400:	2-1/2"	3.5 mm
MSWH400:	3"	76.2 mm
MSW600:	4"	101.6 mm
Liquids Handling	raw unscreened sewage, rain water, effluent	
Intermittent Liquid Temp.	130°F	55°C
Operation	Control panel or capacitor kit required	
Acceptable pH Range	6-9	
Discharge		
MSW400 & MSWH400:	4" ANSI flanged	
MSW600:	6" ANSI flanged	
Sump Diameter Duplex	30"	762 mm
Motor Housing	cast iron	
Power Cord	25'	7.6 m
Shaft Seal	carbon & ceramic	

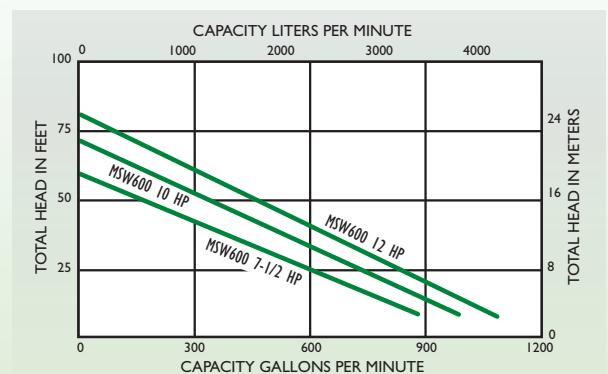
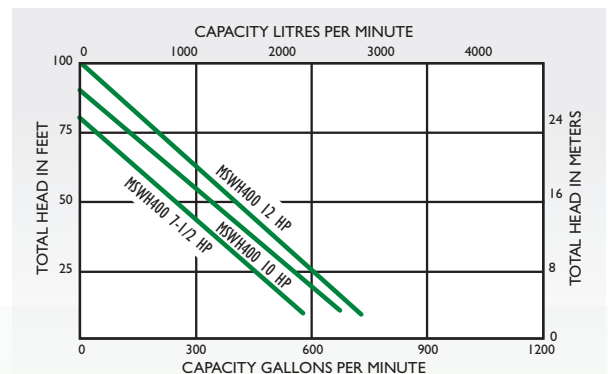
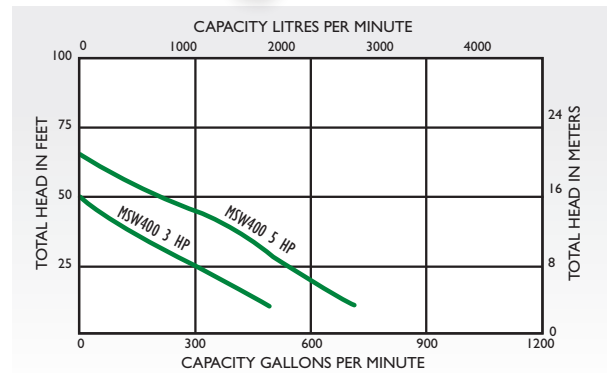

### FEATURES

- 3, 5, 7-1/2, 10 or 12 HP
- Class 30 cast iron construction
- 4" (102 mm) or 6" (152 mm) ANSI flanged discharge
- Carbon/ceramic shaft seal
- Piggyback-style float for automatic or manual operation
- Oil-filled motor with automatic reset overload provides safe operation
- Ball-bearing construction for long life
- Easily replaceable power cord with optional lengths available
- Control panels required (sold separately)



## 4MSW/4MSWH/6MSW SERIES

### 4" & 6" Non-Clog Wastewater Pumps

#### OUTLINE DIMENSIONS

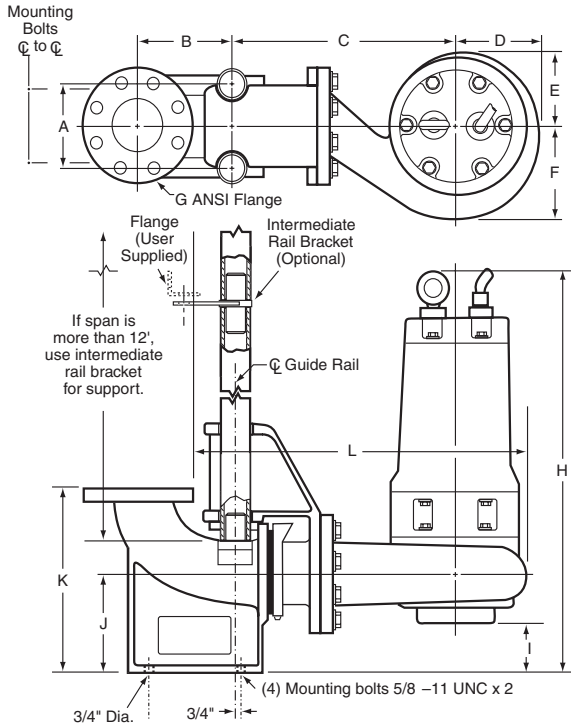

#### SECTIONAL VIEW

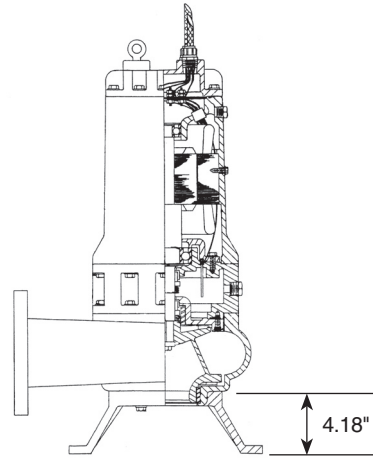

Catalog No.	A	B	C	D	E	F	G	H	I	J	K	L
4MSW Series	6.50	7.75	18.00	6.50	6.00	7.50	4.00	31.40	3.75	7.75	14.00	28.75
4MSWH Series	6.50	8.75	20.00	7.31	6.81	7.79	4.00	33.55	4.75	9.50	16.38	31.75
6MSW Series	6.50	8.75	20.00	7.75	6.75	8.75	6.00	35.50	4.75	9.50	16.38	32.50

Dimensions (in inches) are for estimating purposes only.