

ME45 SERIES

The Myers[®] ME45 series effluent pumps are designed to meet the demand of residential septic tanks or sump applications. This powerful 1/2 HP pump provides flow and head required for demanding dosing systems and drainage applications.

APPLICATIONS

Effluent removal, sump drainage, water transfer, flood control

SPECIFICATIONS

- Capacities – 87 GPM (329 LPM)
- Shut-off Head – 44' (13.41 m)
- Operation – Manual
- Max. Spherical Solids – 3/4" (19 mm)
- Liquids Handling – Domestic effluent and drain water
- Intermittent Liquid Temperature – Up to 140°F (60°C)
- Motor/Electrical Data – 1/2 HP, 3450 RPM, oil-filled, permanent split capacitor type, 115V, 8.6A, 1Ø, 60Hz; 230V, 4.3A, 1Ø, 60Hz
- Acceptable pH Range – 5-9
- Specific Gravity – .9-1.1
- Viscosity – 28-35 SSU
- Discharge, NPT – 2" (50.8 mm)
- Housing – Cast iron
- Minimum Sump Diameter – Simplex: 24" (61.0 cm)
Duplex: 36" (91.4 cm)
- Power Cord – 20', 16/3, SJTW

In order to provide the best products possible, specifications are subject to change.
Myers[®] is a registered trademark of Pentair Water.



Features a
Cast Iron Impeller

FEATURES

Powerful Torque

High-torque, permanent split capacitor (PSC) motor; no starting switches or relays to wear out

Rugged and Cool

Rugged-built, oil-filled motor for continuous bearing lubrication and maximum heat dissipation

Seal Protection

Upper and lower ball bearing and heavy duty Type 6 seal for added pump life

Thermal Protection

Heat sensor overload protection with automatic reset when motor cools to a safe operating temperature



Myers[®]

Pentair Water

EFFLUENT AND DRAIN WATER PUMPS

ORDERING INFORMATION

Catalog Number	HP	Volts	Phase/Cycles	Amps	Discharge Size	Switch Type	Cord Length	Approx. Wt. Lbs.
ME45MC-11	1/2	115	1/60	8.6	2"	Manual	20'	58
ME45MC-21	1/2	230	1/60	4.3	2"	Manual	20'	58

DIMENSIONS

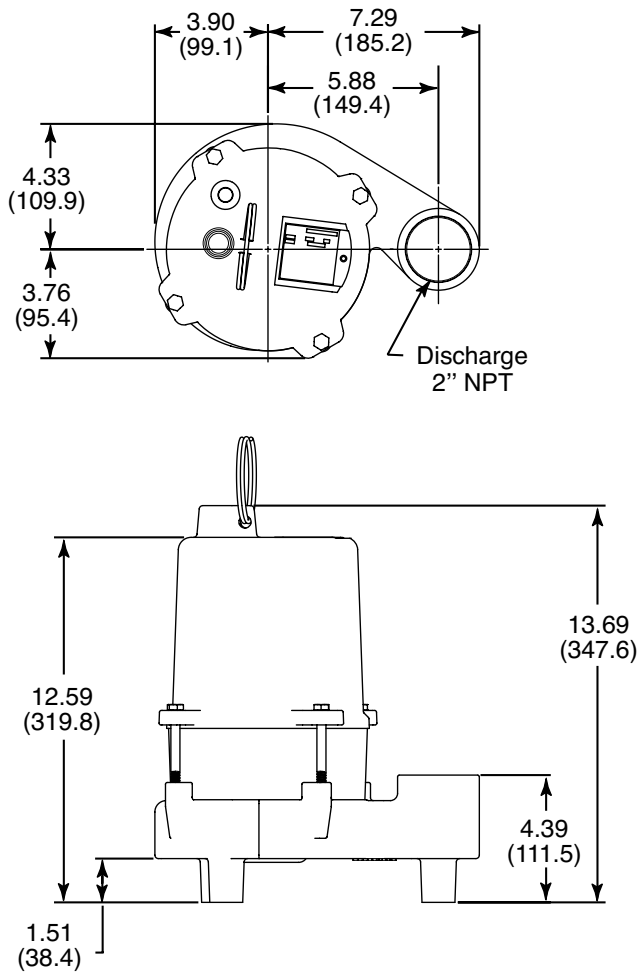

PUMP PERFORMANCE

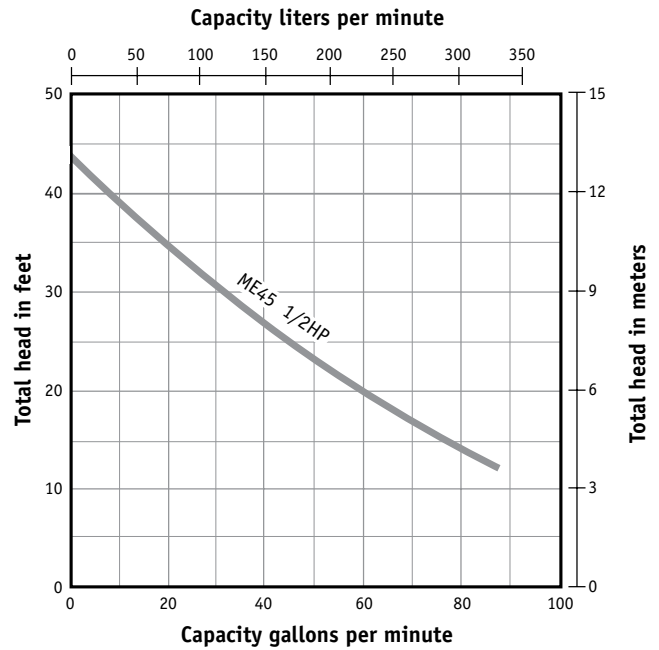

SPECIFICATIONS

EFFLUENT PUMPS – Pump(s) shall be F. E. Myers ME45 Series effluent pump selected in accordance with the following design criteria:

Number of Pumps:	_____
Primary Design Flow:	_____
Primary Design Head:	_____
Minimum Shut-off Head:	44'
Motor Horsepower:	1/2
Motor Speed:	3450 RPM
Electrical:	115 Volts, 1Ø, 60 Hz or 230 Volts, 1Ø, 60 Hz

PUMP – The pump shall be designed to handle septic tank effluent and be capable of passing 3/4 inch spherical solids. The pump shall be capable of handling liquids with temperatures to 140°F intermittent.

MOTOR – The pump motor shall be of the submersible type rated 1/2 hp at 3450 RPM and shall be for _____115 volts or _____230 volts single phase, 60 cycles. Single phase motor shall be PSC motor with no relays or starting switches. Stator winding shall be of the open type with Class B insulation rated for 130°C maximum operating temperature. The winding housing shall be filled with clean dielectric oil to lubricate bearings and seals, and transfer heat from the windings to the outer shell.

The motor shall be capable of operating over the full range of the performance curve without overloading the motor and causing any objectionable noise or vibration. The motor shall have two bearings to support the rotor; an upper sleeve bearing to accommodate radial loads and a lower sleeve bearing with thrust pad to take thrust and radial loads.

A heat sensor thermostat and overload shall be attached to the top end of the motor windings and shall be wired in series with the windings to stop the motor if the motor winding reaches 200°C. The overload thermostat shall reset automatically when the motor cools to a safe operating temperature.

POWER CORD – The motor power cord shall be 20 feet SJTW type. The power and switch cords shall be of the positive sealing type. The power and switch cable connections shall be sealed at the motor entrance by means of a compression nut which serves to make a positive electrical connection and prevent water from entering the cable jacket and motor housing.

SHAFT SEAL – The motor shall be protected by a rotating mechanical shaft seal. The seals shall have carbon and ceramic seal faces lapped to a tolerance of 1 -3 light band. Metal parts and springs for seals shall be 18 - 8 series stainless steel.

PUMP IMPELLER – The pump impeller shall be of the two vane semi-open type. The impeller shall be constructed of cast iron.

MOTOR HOUSING – The motor housing castings shall be of high tensile strength Class 30 gray cast iron. Castings shall be painted with a high quality, 1/8" thick (per UL778) baked epoxy spray for corrosion protection.

PUMP CASE – The pump case shall be a high efficiency volute design capable of passing 3/4 inch spherical solids. The pump volute shall be constructed of cast iron.

FASTENERS – All exposed fasteners shall be of 300 series stainless steel.



EFFLUENT AND DRAIN WATER PUMPS

