

S33 Series

1/3 Horsepower
Submersible Sump Pump



Available with vertical mechanical switch (not shown)

THE F. E. MYERS 1/3 HP S33 SUBMERSIBLE SUMP PUMP BUILDS ON THE MYERS TRADITION OF INNOVATION AND QUALITY. THE S33 FEATURES OUR INTERCHANGEABLE, POSITIVE SEALING SOCKET DESIGN FOR EASY REPLACEMENT OF BOTH POWER AND MERCURY-FREE MECHANICAL FLOAT AND VERTICAL SWITCH CORDS, AND OUR RECESSED IMPELLER.

This 1/3 hp pump achieves a shut-off head of 25 feet and a maximum flow of 32 gpm. Its 3450 rpm oil-filled permanent split capacitor (PSC) motor provides superior heat dissipation and built-in overload protection. Accurate shaft alignment and easy serviceability are assured by this permanent split capacitor motor, which is protected from water damage by a carbon-ceramic mechanical shaft seal and additional lip seal. The operating mode is easily switched from automatic to manual, without removing the motor cap, by inserting a shunt plug. The S33 is also available with a vertical mechanical switch. In this configuration, the S33 can be installed in a 10½" diameter sump. For more information about the S33 and Myers complete line of residential wastewater pumps, please talk to your Myers representative or call 419-289-1144.

ADVANTAGES BY DESIGN

DURABLE MOTOR WILL DELIVER MANY YEARS OF RELIABLE SERVICE

- Oil-filled motor for maximum heat dissipation and continuous bearing lubrication.
- PSC motor eliminates starting switches.
- Recessed vortex impeller operates completely out of volute. Provides free flow through passage for solids and liquid, and has minimal radial loading for long bearing life.

THE S33 IS ENGINEERED FOR MANY YEARS OF MAINTENANCE-FREE OPERATION.

- If service is ever necessary, positive sealing, quick-disconnect power and switch cords make replacement simple.
- Choice of wide-angle mercury-free mechanical float switch for maximum drawdown (built-in or piggyback), or vertical mechanical switch which allows installation in small 10½" sumps.

PRODUCT CAPABILITIES

Capacities To	32 gpm	145 lpm
Heads To	25 ft.	7.62 m
Pump Down Range		
Float Switch	7 in.	178 mm
Vertical Switch	4-1/8 in.	107 mm
Solids Handling Capacity	1/4 in.	6.4 mm
Liquids Handling	drain water	
Intermittent Liquid Temp.	up to 140°F	up to 60°C
Motor	1/3 HP PSC Motor 3450 RPM	
Electrical	115V, 6.5 amps, 1 ph, 60 Hz.	
Acceptable pH Range	6-9	
Discharge, NPT	1-1/2 in.	38.1 mm
Min. Sump Diameter		
Float Switch	18 in.	457 mm
Vertical Switch	10-1/2 in.	254 mm

Construction Materials

Motor Housing	cast iron
Motor Cap	flame retardant thermoplastic
Volute Case	thermoplastic
Impeller	recessed, thermoplastic
Power Cord	10 ft. 16/3 SJTW/SJTW-A or 20 ft. 16/3 SJTW/SJTW-A
Mechanical Seal	type 11A, carbon and ceramic

WHERE INNOVATION MEETS TRADITION

Myers[®]

Pentair Pump Group

S33 Series

1/3 Horsepower
Submersible Sump Pump

POWER AND FLOAT CORDS

Quick-connect, water-tight fittings are interchangeable, replaceable from pump exterior.

MERCURY-FREE MECHANICAL FLOAT SWITCH

(S33A1 and S33A1C
S33P-1 and S33PC-1)
90 degree operation.
OR

VERTICAL MECHANICAL SWITCH

(S33V1 and S33V1C)
allows installation in small sumps.
(float switch not shown)

LIP SEAL

Provides extra level of sealing protection.

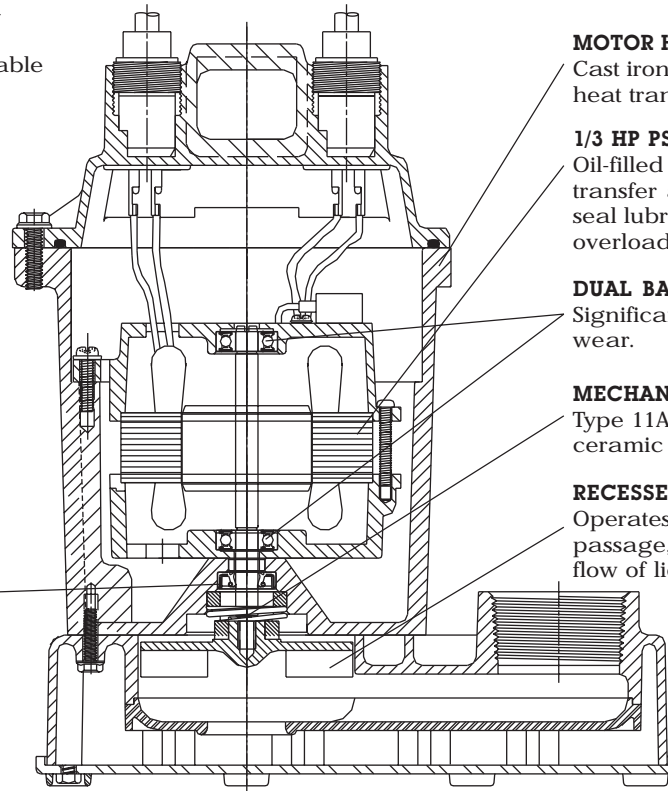

MOTOR HOUSING

Cast iron for efficient heat transfer.

1/3 HP PSC MOTOR

Oil-filled for best heat transfer and bearing and seal lubrication. Built-in overload protection.

DUAL BALL BEARINGS

Significantly reduces motor wear.

MECHANICAL SHAFT SEAL

Type 11A with carbon and ceramic faces.

RECESSED IMPELLER

Operates out of volute passage, allowing maximum flow of liquids and solids.

DIMENSIONS

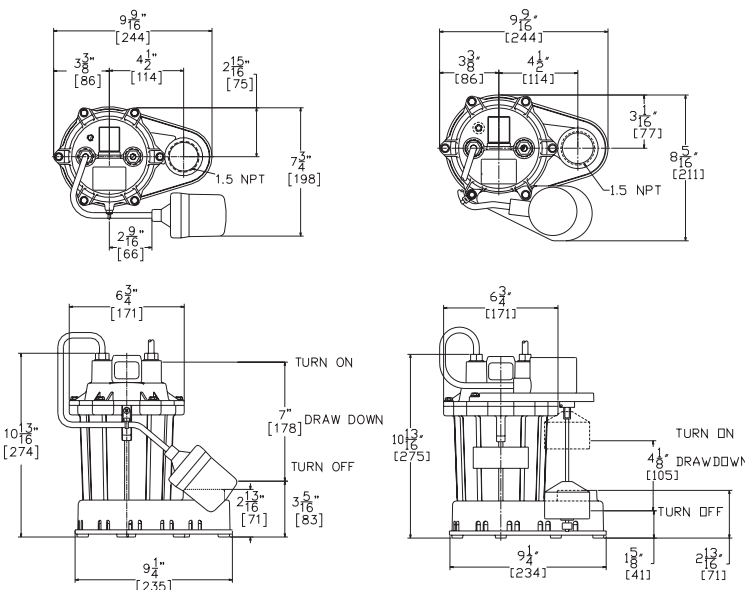

PERFORMANCE CURVE

