

# NETZSCH

## C.Pro<sup>®</sup> Benchmark in Dosing Technology

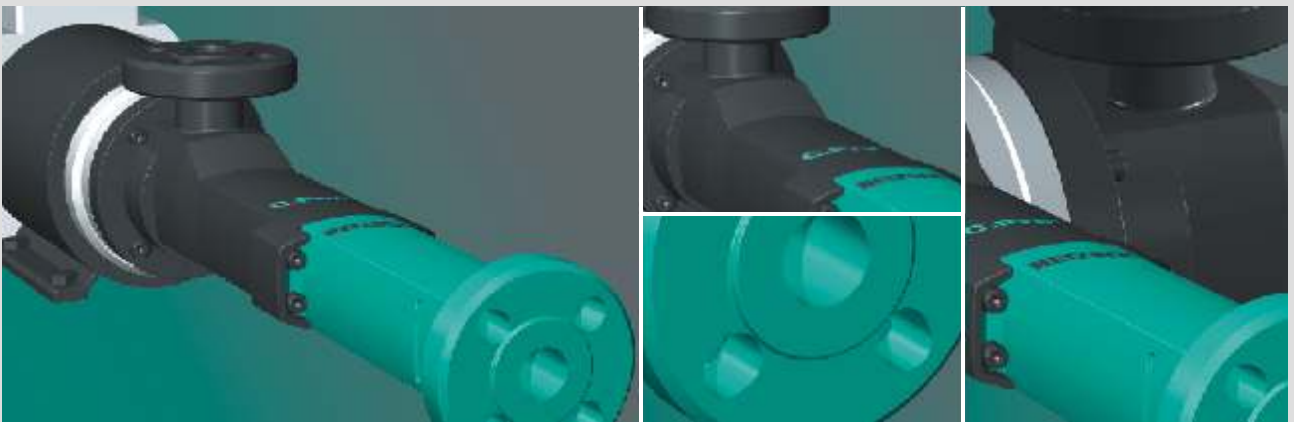

The heart of your process. ■

# C.Pro<sup>®</sup> – economic, environmentally and service friendly Characteristics and Construction

**NETZSCH**

## Universal Use

C.Pro<sup>®</sup> is a new and innovative pump series for conveying and metering small capacities. It has been developed from a continuing evolution of the well known NEMO<sup>®</sup> Mini and M.Champ<sup>®</sup> progressing cavity pumps. An important aim of this development has been the significant reduction of parts. With now only 6 parts the C.Pro<sup>®</sup> is unmatched in economy and service friendliness. Through the use of highly resistant PU (Baydur<sup>®</sup> GS) for the housing and PVDF for the rotating unit the installation possibilities for the C.Pro<sup>®</sup> are almost unlimited.

## Wide Range of Applications

The C.Pro<sup>®</sup> has been designed especially for the use in water processing, waste water treatment and in the chemical industry for continuous and nearly pulsation free metering of process additives. The C.Pro<sup>®</sup> is specifically designed for products with the following characteristics:

- Products with or without solid particles
- Low to medium viscosity (up to 20.000 mPas)
- Thixotropic and dilatant
- Shear-sensitive
- Abrasive
- Lubricative and none lubricative
- Aggressive (pH 0 - 14)
- Adhesive
- Toxic

## Large Range of Capacities and Pressures

- Capacity from 5 to 1000l/h
- Pressures up to 15 bar

## Typical Media

- Natural and artificial polymers
- Anionic and cationic polyelectrolytes
- Iron and aluminium salt solutions (e.g. Ferro III Chloride)
- Lime milk
- Water and waste water samples
- Suspensions
- Dispersions
- Alcohols
- Esters / amides
- Ketones / aldehydes
- Oils
- Further applications also mixed products on request

## Advantages

- Continuous and low pulsation conveyance
- Speed proportional metering
- Reversible direction of rotation and conveyance
- High suction and pressure capacity
- Single part rotating unit
- Mechanical seal in product flow
- Maintenance free and service friendly
- Compact and economic

## Further Features

- Temperature 0 to 40°C
- High metering precision with deviation +/- 1%

NEMO<sup>®</sup> C.Pro<sup>®</sup>  
Plastic Dosing Pump

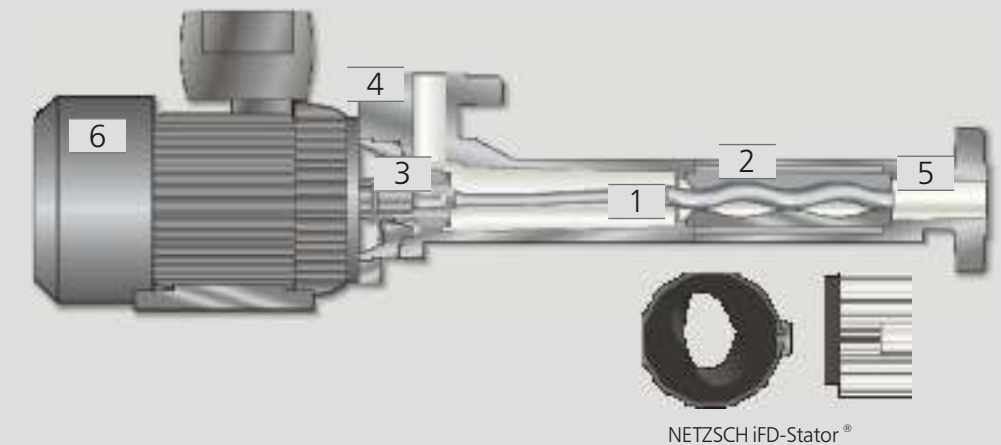

### 1 Rotating Unit

The rotating unit normally used in NEMO<sup>®</sup> progressing cavity pumps consists of a number of parts, used on the one hand to transfer the torque to the conveying element and on the other hand to take up the eccentric movement of the rotor and the axial forces caused by the discharge pressure. With the new single part, joint and maintenance free rotating unit made of plastic, 8 parts have been removed. This makes the pump highly economic and service friendly. For applications whereby abrasive or non lubricating media have to be pumped the C.Pro<sup>®</sup> is available with a chrome plated, CrNiMo 17-12-2 stainless steel, rotor.

### 2 Stator

The C.Pro<sup>®</sup> is fitted as standard with an iFD-Stator<sup>®</sup>. The stator consists of a reusable stator housing with a polygonal profile and an elastomer stator core. The advantages of this new technology are reduced starting torque, higher efficiency, increased life times as well as easy replacement and disposal. Two elastomer qualities based upon EPDM and Viton<sup>®</sup> are available.

For further information simply order brochure NMP • 344/02

### 3 Mechanical Seal and Housing

The crevice free mechanical seal is positioned in the product flow, ensuring permanent flushing by the medium and preventing the sedimentation of solid materials. As standard a fully encapsulated single-acting mechanical seal to DIN 24960 is installed. The seal has faces in solid SiC and is suitable for use in both directions of rotation.

### 4 Suction Housing

The housing is made out of abrasion proof and highly resistant polyurethane. The universal flange DN20 PN16 to DIN and ¾" to ANSI B16,5 150 LBS makes installation and removal from the plant easy.

### 5 Stator and Discharge Housing

The connection is made out of abrasion proof and highly resistant polyurethane. Again the universal flange DN20 PN16 and ¾" ANSI B16,5 150 LBS makes the mounting into and the removal from the plant easy.

### 6 Drive

As standard delivered with a 6 pole three phase motor and frequency converter for control panel mounting. As an option also available with 6 pole three phase motor complete with cooling fan and integrated frequency converter for manual speed control via integrated potentiometer or control by a 4-20 mA/2-10 V signal. The drive is complete with an illuminated on / off switch, a direction reversing switch and a 1.5 m power cable with CE or US plug.

# NETZSCH

---

[www.netzsch.com](http://www.netzsch.com)

---

---

NETZSCH Mohnopumpen GmbH  
Geretsrieder Straße 1  
84478 Waldkraiburg  
Deutschland / Germany  
Phone: +49 8638 63-0  
Fax: +49 8638 67981

E-mail: [info.nmp@netzsch.com](mailto:info.nmp@netzsch.com)  
[www.netzsch.com](http://www.netzsch.com)

---