



NIKKISO NON-SEAL[®] PUMPS



CANNED MOTOR PUMPS

NIKKISO CO.,LTD.

NIKKISO NON-SEAL® PUMPS

NIKKISO Company Limited, a pioneer in "Canned Motor Pumps", began production in Japan beginning in 1957. NIKKISO is now one of the largest manufacturers of "Canned Motor Pumps" in the world. "NIKKISO Non-Seal®", a registered trade mark, is another commonly used term for "Canned Motor Pumps". Canned Motor Pumps were firstly created to meet the zero leakage and maximum reliability requirements of the nuclear power industry. Since then, NIKKISO Non-Seal® Pumps have been continually refined over the past 50 years to economically meet the requirements of safety, reliability and maintainability of the chemical and petrochemical industries. Today, because of our advantages, NIKKISO Non-Seal® Pumps are widely used in general industries, even on water applications.

- SAFE** No seals to leak. Double Containment, consisting of an inner stator liner plus an external stator pressure-containing shell, prevents leakage to the environment. This minimizes both immediate and long-term risks to personnel.
- LOW NOISE** Totally enclosed with neither motor fans nor exposed bearings.
- LOW VIBRATION** No motor fans and no couplings
- E MONITOR** Monitoring of bearing wear in real time.
- NO ALIGNMENT REQUIRED** No couplings.
- SMALL, COMPACT AND SELF CONTAINED** The integral pump and motor makes efficient use of space. Installation costs are reduced with minimal foundation requirements.
- LOW ROUTINE MAINTENANCE** No motor bearings to lubricate, no pump bearings to lubricate, no coupling alignment or lubrication, no buffer pots to fill.
- EASY TO ASSEMBLE** No shimming or clearance setting required.



CONVENTIONAL CENTRIFUGAL PUMPS WITH DOUBLE MECHANICAL SEALS

Environment pollution or fire in chemical plants is caused by liquid leakage from mechanical seals. Large space is required for installation. Flushing is required. Noise generated from coupling and motor fan. Increase maintenance costs for changing mechanical seals. Daily checking -----leakage from mechanical seals and making-up lubricant.

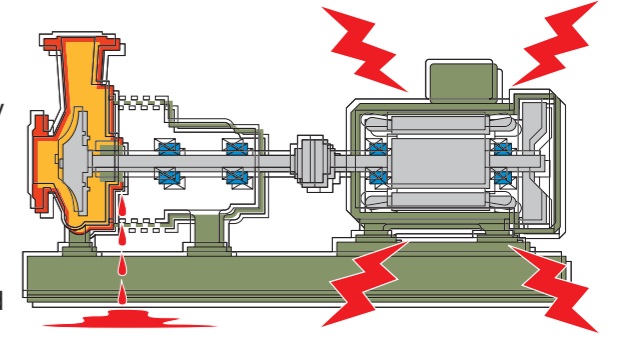

MAGNETIC DRIVE PUMPS

No secondary leak containment. No effective way to control bearing fluid environment-----sensitive to solids and vaporization. No way to monitor wear of impeller shaft bearings. Coupling misalignment leads to input bearing failure and rubbing of containment shell. Noise generated from coupling and motor fan. Efficiency is widely down in high temperature application. Not suitable for high pressure design.

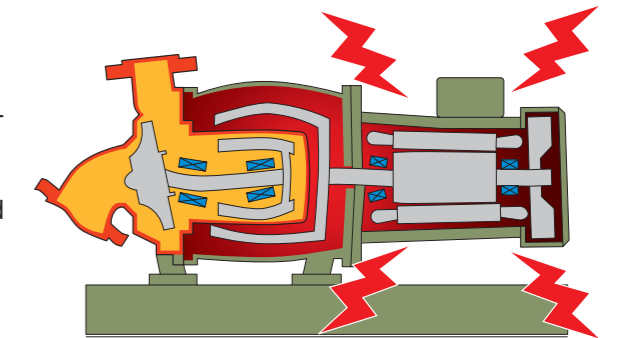

E MONITOR

NIKKISO E MONITOR was developed to detect the condition of bearings of hermetically sealed pumps during operation. In order to achieve this, the position of the rotor is monitored while the pump is operating. Bearing wear will be indicated. The technical excellence of the E MONITOR is useful in predictive maintenance necessitated by bearing wear. The E MONITOR is energized by power from the incoming motor leads and does not require additional wiring.

Indication:

- Wear of front or rear radial bearing
- Uneven wear of front or rear bearing
- Wear of front or rear axial bearing
- Power on (pump is operating)
- Direction of rotation (correct or incorrect)

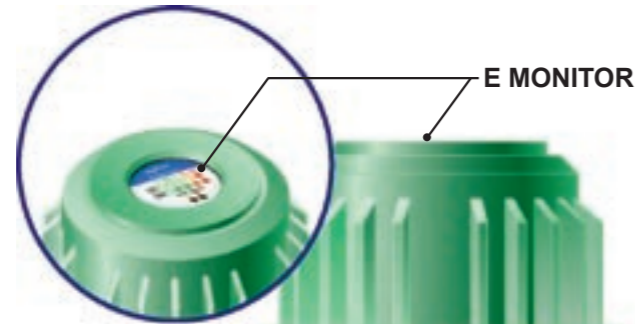

Principle of E MONITOR

When bearing wear occurs, the rotor assembly shifts along the radial and/or axial position. These minute shifts are detected by eight search coils embedded in the stator, enabling precise readings of bearing wear in both directions. Real-time bearing status is conveniently displayed on an easy-to-read LED display.

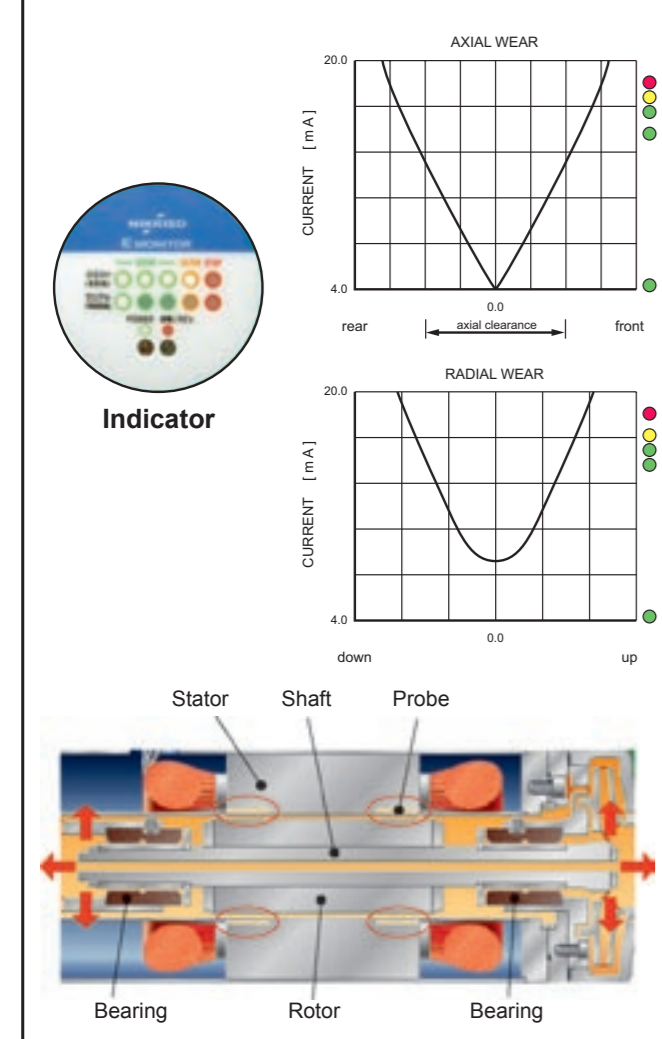

Terminal Plate
O-ring sealing for positive secondary fluid containment.

Shaft Sleeves
Available in a variety of surface treatments to suit the specific fluid application. Replace when bearing are changed for new wear surface and clearance.

Bearings
Available in a variety of materials to suit the specific fluid application.

Thrust Washers
Absorb thrust loads during upset conditions and provide back-up to hydraulic thrust balancing.

Stator Band

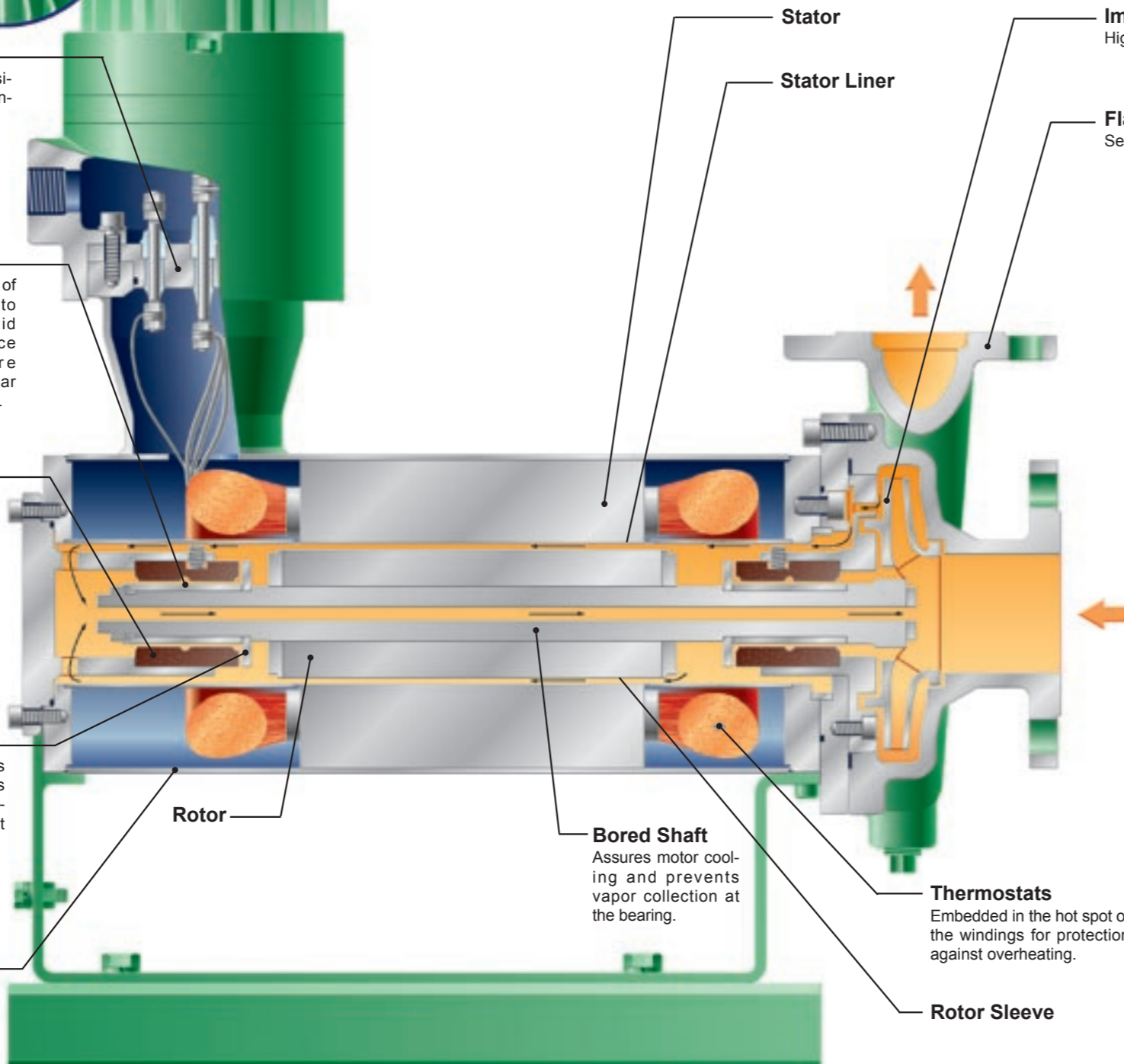

MOTORS

In the NIKKISO Non-Seal® Pump design, the entire outside of the motor is enclosed in a secondary leakage containment shell or can. Primary leakage protection is provided by corrosion resistant liners which are seal welded and 100% leak checked to assure that pumped fluid does not contact the stator windings or rotor core. There is no shaft protrusion to seal and thus no seals to leak. Pumped fluid is circulated in the area between the rotor and stator liner to cool the motor, and lubricate the bearings. Motor windings and insulation system are specially designed, developed and applied as an integral part of the pump so that design life is at least as great as for conventional air cooled motors. Winding temperature is primarily influenced by pumped fluid temperature and secondarily by use of cooling jacket. Fluid temperature is considered in pump application to assure full winding life. Thermostats are embedded in the hot spots of windings for tripping off the motor in case of overheating.

AUTOMATIC THRUST BALANCE

The hydrodynamic action of a set of fixed and variable orifices provides automatic thrust balancing to center the shaft between thrust bearings. This eliminates thrust bearing wear during normal operation. Contact between the replaceable thrust washers and the thrust face of the carbon bearings occurs only during start up and upset conditions such as loss of suction. By controlling thrust loads at the impeller, motor cooling flow is not affected by shaft position.

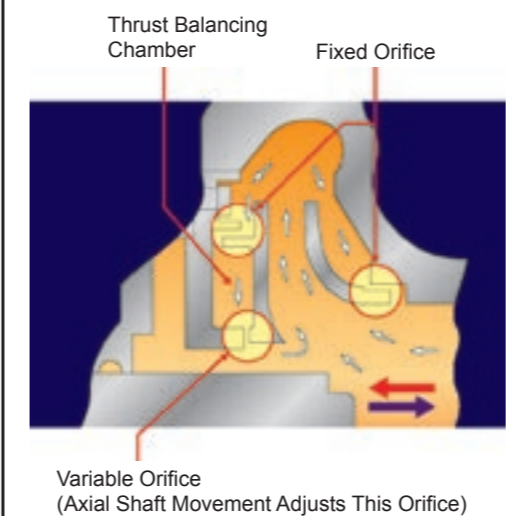

PUMP MODEL CODES

Model
H : Horizontal
L : In-line
B : Motor top
T : Pump top
D : Self-priming
S : Submerged

Construction
N : Basic
V : High viscous
T : High temperature with thermal isolation spacer
S : Slurry liquid with seal ring
M : Slurry liquid with mechanical seal
G : Slurry liquid with gas seal
Q : Reverse circulation
R : Reverse circulation with adapter
B : High melting
C : High melting (simple type)
W : Basic external circulation
Y : No cooled high temperature, liquid temperature max. 250°C (482°F)
X : No cooled high temperature, liquid temperature max. 350°C (662°F)

Pump model
21A/B/C
22A/B/C/D/E
23A/B/C/D/E/F/G
24A/B/C/D/E/F
25B/C/D/E/F
26C/D/E/F
27E/F
46A/B
47B/C/D
48C/D/E
49C
42X
X12/22/32/42
461, 631, 632

Jacket and Heat Exchanger for Casing and Rear Bearing Housing
X : None
P : with welded type jacket on casing
Q : with casting type jacket on casing
R : with casting type jacket on casing and welded type jacket on rear bearing housing
S : with welded type jacket on casing and rear bearing housing

Motor size
A1~A3
B1~B3
C1~C4
D1~D3
F1~F4
G1~G3
H1~H2
J1~J4
K1~K4
N1~N3
L1~L3
M1~M3
A5, B5, C5, G5

Power supply voltage
A : 190-211V@50Hz 200-223V@60Hz
G : 375-424V@50Hz 400-449V@60Hz
H : 425-474V@50Hz 450-499V@60Hz
Other voltages are available.

Max. allowable working pressure
01 : 1 MPa (150 psig)
02 : 2 MPa (300 psig)
03 : 3 MPa
04 : 4 MPa (600 psig)

Material code
C1 : SUS304
C2 : SUS304L
D1 : SUS316
D2 : SUS316L
E1 : CA20 (Alloy 20)
G2 : Hastelloy C

Winding Insulation Class
F : F class
C : C class

Ex-proof code
A : d2G1
B : d2G2
C : d2G3
D : d2G4
E : eG1
F : eG2
G : eG3
H : eG4
I : ed2G2
L : ed2G3
M : ATEX EEExde IICT1
N : ATEX EEExde IICT2
O : ATEX EEExde IICT3
T : TE
W : ATEX EEExde IICT4
X : ATEX EEExde IICT5

Jacket and Heat Exchanger for Motor
X : None
J : with mount type jacket
K : with mount type jacket, jacket and stator band material SUS304
L : welded type jacket material steel
M : welded type jacket, jacket and stator band material SUS304
N : welded jacket cooling with pump un liquid, material same as pump
C : with heat exchanger
D : with heat exchanger, heat exchanger and stator band material SUS304
E : with separated heat exchanger

Model Code Example: H N 21A - A1 C A C - 01 D1 X X

SPECIFICATIONS

	Standard	Semi-Standard
Max. Capacity	780m ³ /h (3,430 gpm)	1200m ³ /h (5,280 gpm)
Max. Head	300m (984ft)	600m (1,970ft)
Fluid Temp. Range	-60 to 350°C (-76 to 662°F)	-200 to 450°C (-328 to 842°F)
Specific Gravity Range	0.3 to 2.0	Max. 13.6
Max. Viscosity	200 mPas (200cP)	500 mPas (500cP)
Max. Working Pressure	4 MPa (600 psig)	80 MPa (11,600psig)
Motor Power Range	0.4 to 200kW (0.5 to 268hp)	200 to 270kW (268 to 360hp)
Liquid End Material	SUS316, SUS304	Alloy 20, Hastelloy C/B, Titanium, Zirconium, etc.

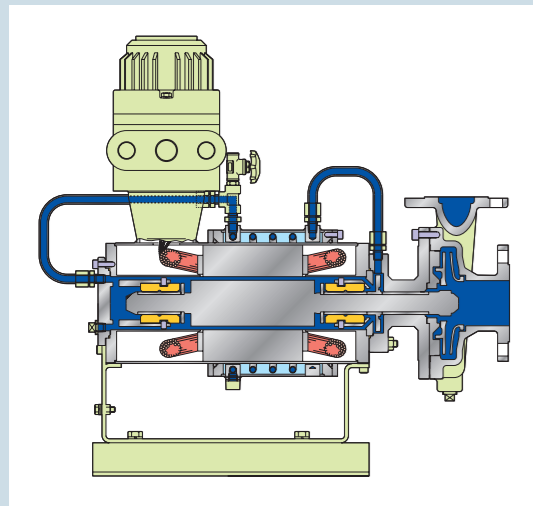

Type HT
High Temperature with Cooling

Designed for hot fluid applications. Process fluid is recirculated within the motor section via an auxiliary impeller. An integral shell and tube heat exchanger and thermal isolation spacer are provided to maintain cool fluid temperatures within the motor, maintaining an acceptable motor winding temperature.

Capacity up to 780 m³/h (3,430 gpm)
Head up to 300 m (984 ft)
Motor up to 200 kW (268 hp)
Temperature up to 400 °C (752 °F)

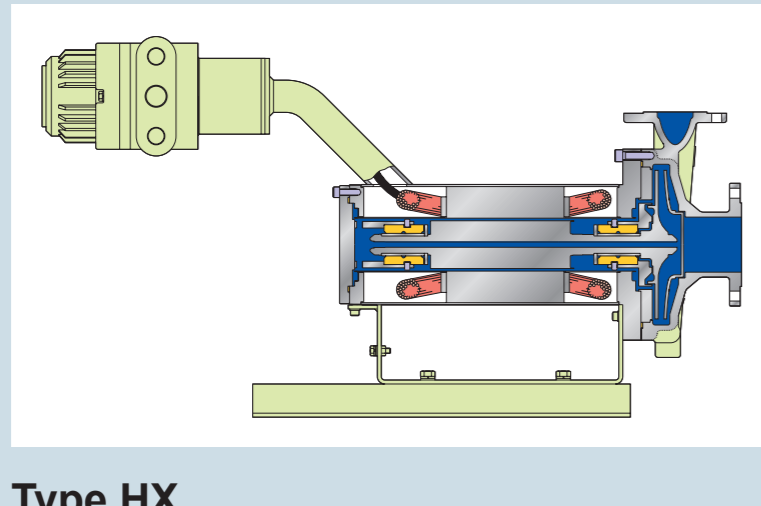

Type HX
High Temperature No Cooling Required

Heat Transfer System Service. The type HX utilizes an exclusive all ceramic motor insulation system and can be externally insulated for maximum system thermal efficiency, making it ideal for heat transfer oil services. Optional jacketing in conjunction with the ceramic motor insulation system makes the HX well suited for handling high melting point liquids (above 140 °C (285 °F)) which would exceed the temperature limit of normal organic motor insulation materials.

Capacity up to 200 m³/h (880 gpm)
Head up to 200 m (656 ft)
Motor up to 55 kW (74 hp)
Temperature up to 350 °C (662 °F)

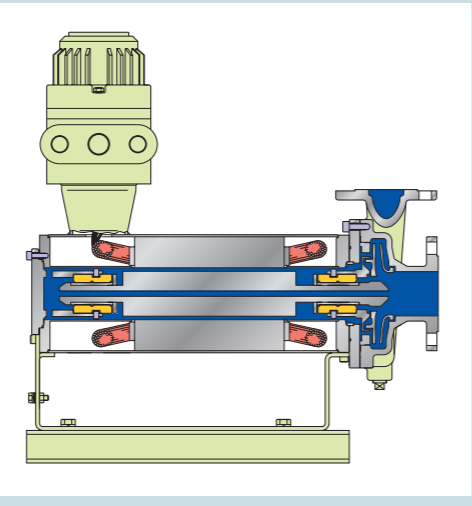

Type HV
High Viscous Liquids

Capacity up to 180 m³/h (800 gpm)
Head up to 200 m (660 ft)
Motor up to 44 kW (59 hp)
Viscosity up to 200 mPas (200 cP)

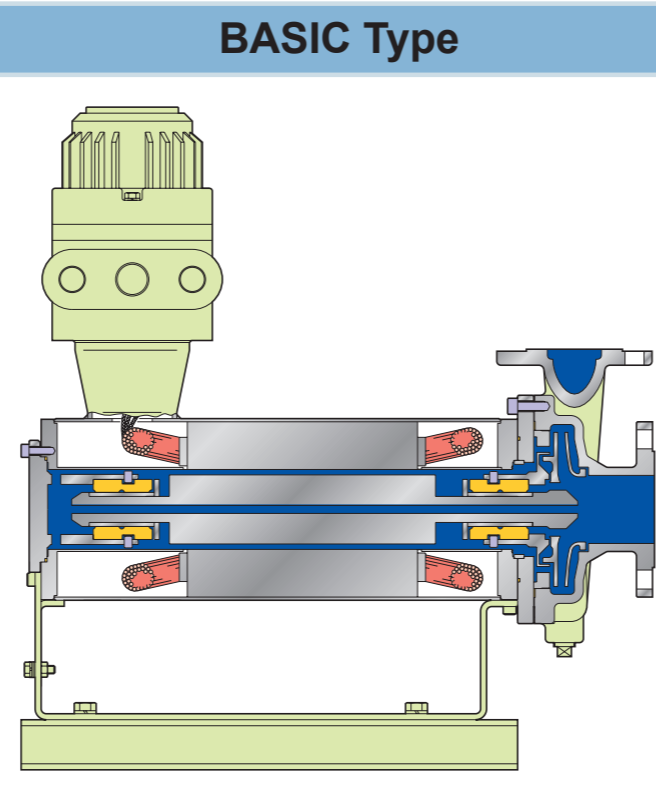

BASIC Type

Type HN

Suitable for a broad range of clean, nonvolatile liquids with moderate temperatures.

Capacity up to 780 m³/h (3,430 gpm)
Head up to 300 m (984 ft)
Motor up to 200 kW (268 hp)
Temperature -60 to +200 °C (-76 to +392 °F)

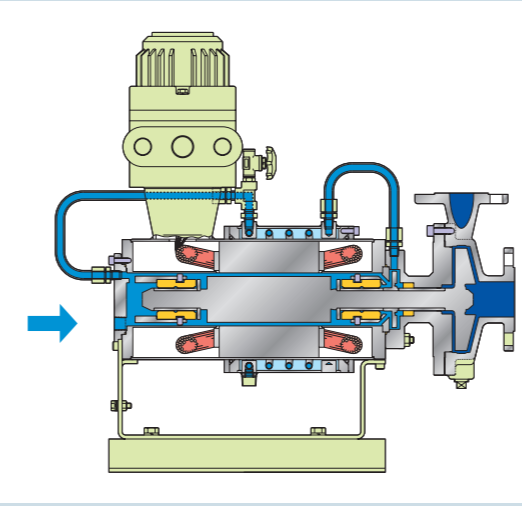

Type HS
Slurry Handling

A clean, compatible flush fluid supply is required and is constantly recirculated within the motor section to provide cooling and bearing lubrication and prevent solids or high vapor pressure liquids from migrating into the motor chamber. Recirculation is accomplished by use of an auxiliary impeller. An integral heat exchanger is provided to remove heat from friction and electrical inefficiency. Flush fluid loss to the process stream is minimized by a close clearance bushing between the motor and pump end. Although flush fluid required (similar to conventional pumps with double seal) there is no shaft protrusion to seal and no seal to leak. Type HM is available utilizing a mechanical seal for reduced flush rates.

Capacity up to 780 m³/h (3,430 gpm)
Head up to 300 m (984 ft)
Motor up to 200 kW (268 hp)
Temperature up to 400 °C (752 °F)

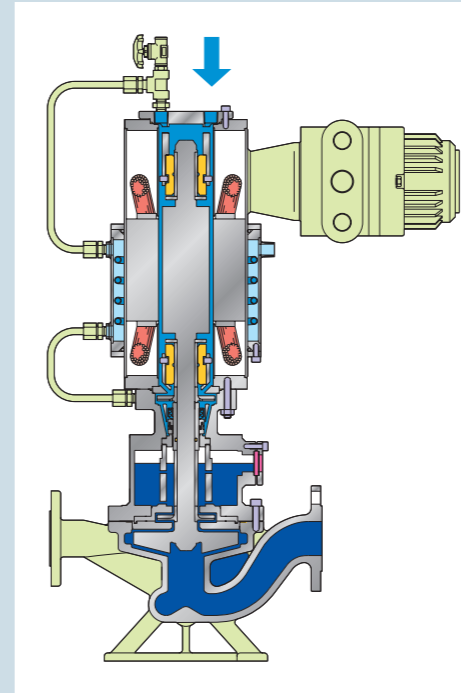

Type LG
Slurry Handling with Gas Seal Structure

Vertical In-line type with mechanical seal Gas chamber between pump casing and motor prevents to damage mechanical seal by solids.

Capacity up to 90 m³/h (400 gpm)
Head up to 80 m (260 ft)
Motor up to 22 kW (30 hp)

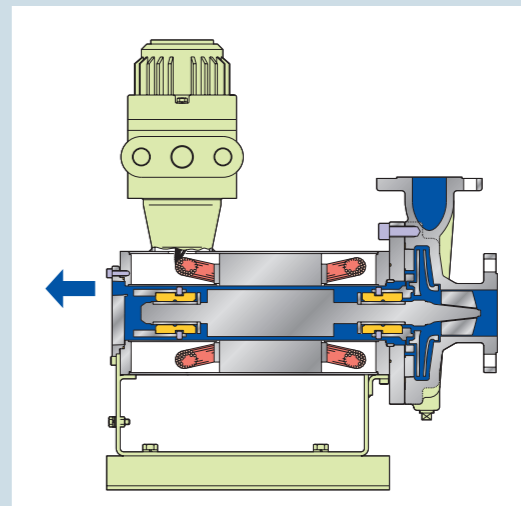

Type HQ
Reverse Circulation

Designed for fluids with steep vapor pressure curves which would tend to flash to vapor if returned to impeller eye after picking up motor heat. The type HQ utilizes a flow through the motor to the vapor zone of the suction vessel. The return line is throttled to maintain high pressure liquid within the motor and also serves as a vent line normally installed for this type fluid.

Capacity up to 180 m³/h (800 gpm)
Head up to 200 m (660 ft)
Motor up to 44 kW (59 hp)

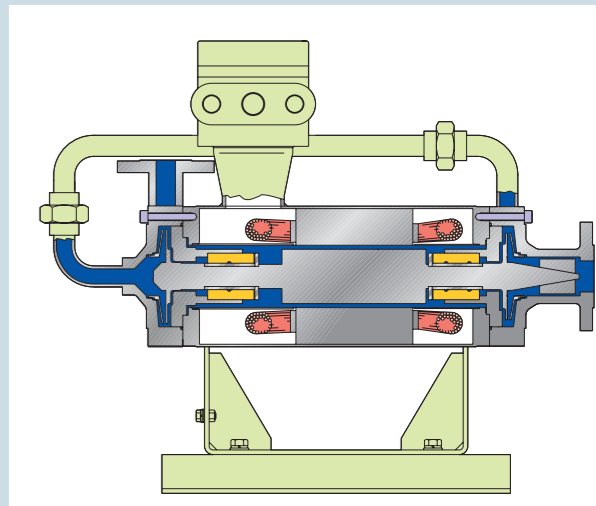

Type HK
Low Flow & Higher Head, High Speed

Suitable Liquid is water or ammonia solution etc.

Capacity up to 10 m³/h (44 gpm)
Head up to 200 m (660 ft)
Motor up to 15 kW (20 hp)
Speed up to 7,200 rpm

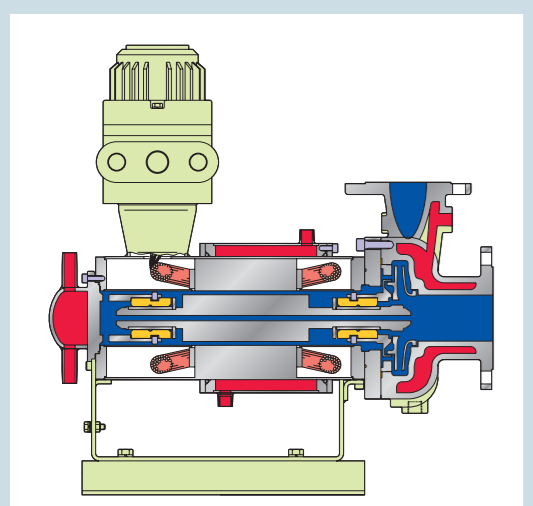

Type HB
High Melting Point with Jacket

The type HB features complete jacketing of the pump case, motor stator and rear bearing housing for temperature control when handling fluids with melting points in the range of ambient to 140 °C (285 °F).

Capacity up to 160 m³/h (700 gpm)
Head up to 200 m (660 ft)
Motor up to 22 kW (30 hp)
Temperature up to 200 °C (392 °F)

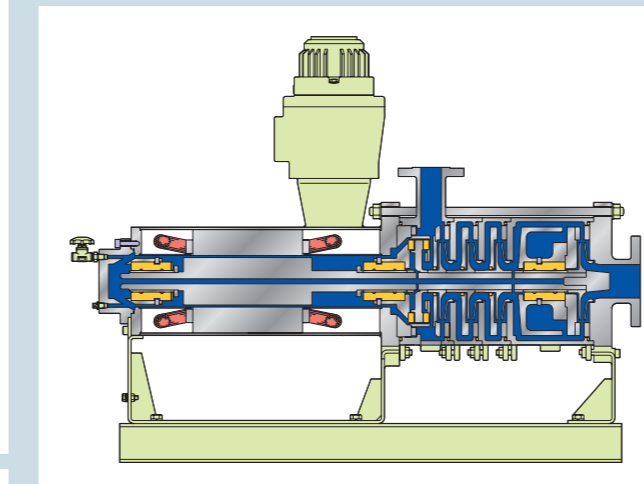

Multistage

Efficient operations in high head applications

Capacity up to 120 m³/h (530 gpm)
Head up to 500 m (1,640 ft)
Motor up to 132 kW (177 hp)
Temperature -30 to +150 °C (-22 to +302 °F)
Viscosity up to 140 mPas (140 cP)

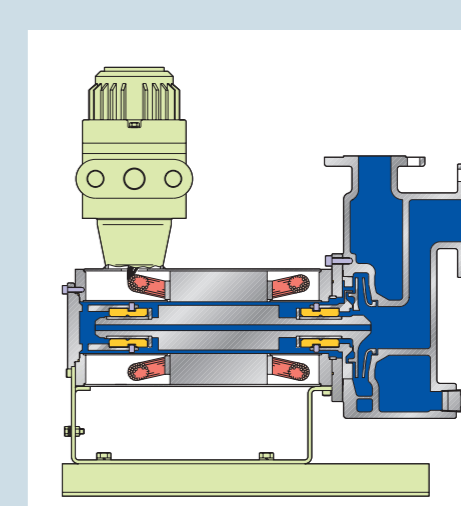

Type DN
Self Priming

Self priming volute casing without flap valve minimizes clogging troubles.

Capacity up to 180 m³/h (790 gpm)
Head up to 70 m (230 ft)
Motor up to 45 kW (60 hp)
Temperature up to 170 °C (338 °F)
Self Priming Head (Water 20 °C) up to 7 m (23 ft)

- High Viscous Liquids
- High Temperature Liquids
- High Melting Point Liquids
- Slurry Liquids
- High Vapor Pressure Liquids
- High Speed
- High Differential Head
- Self Priming

HEAD-CAPACITY ENVELOPE

50Hz

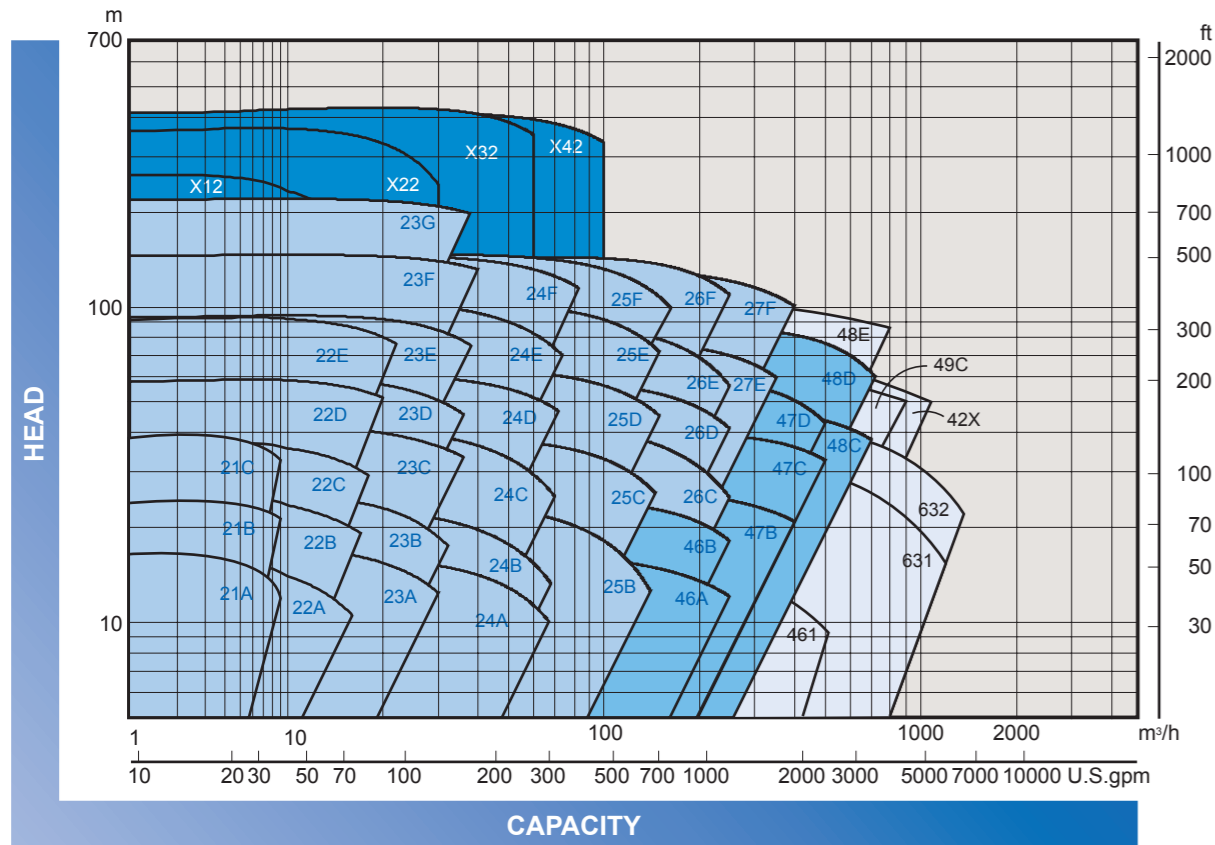

60Hz

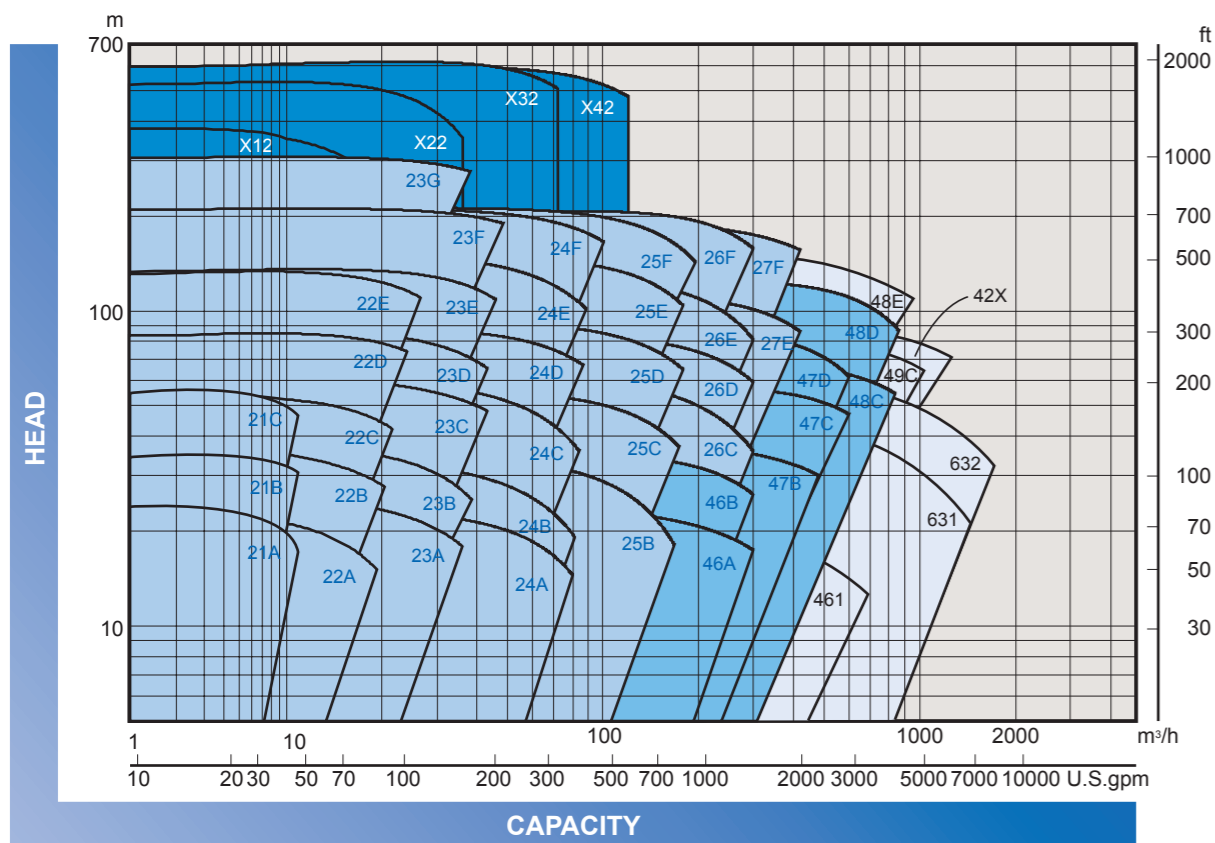

API 685 FULL COMPLIANCE VERTICAL IN-LINE TYPE

NIKKISO Canned Motor Pumps that comply with both API 685* and ATEX* can be used for handling the most volatile liquids in the petroleum and chemical industries.

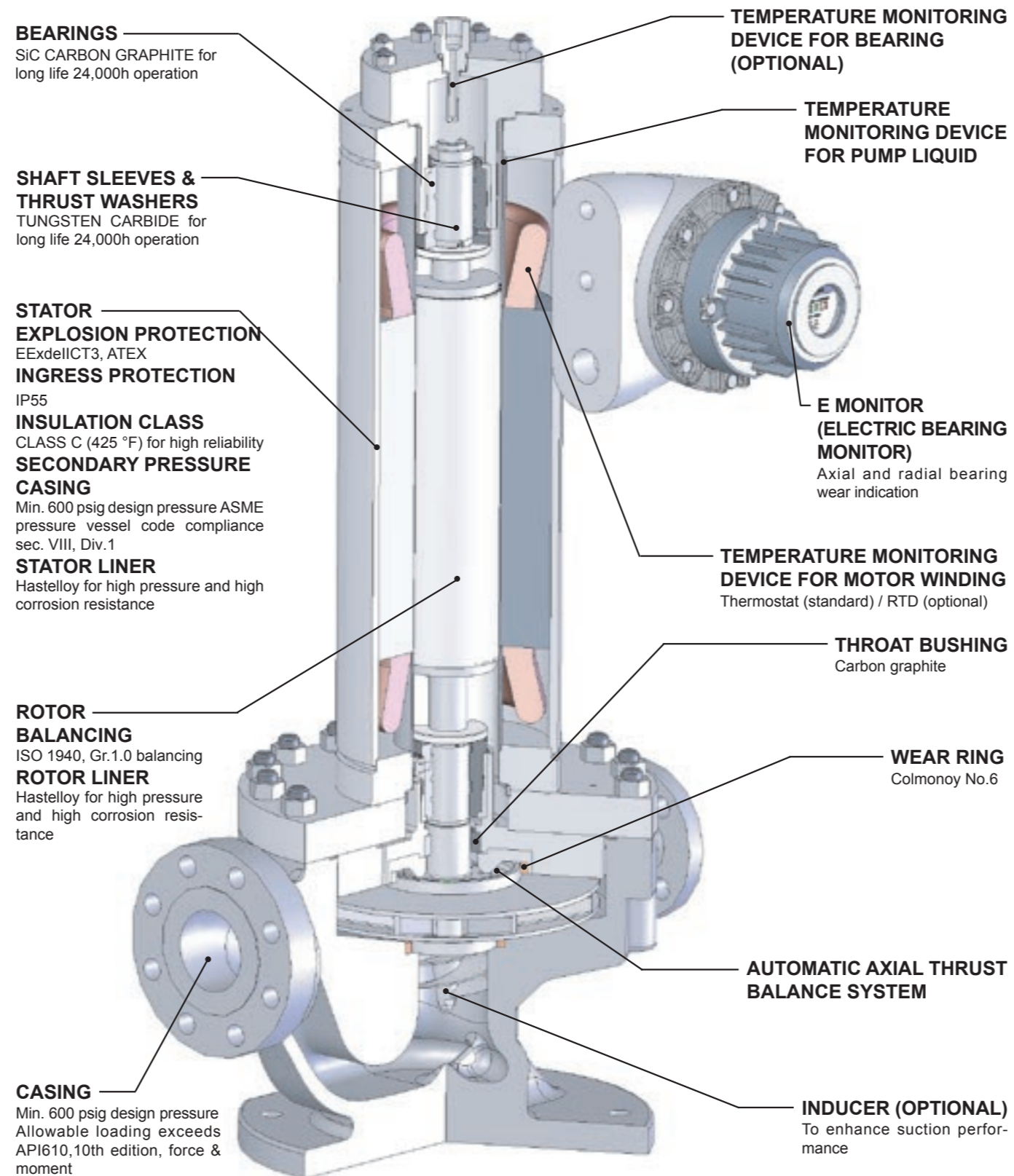

*API 685 : Sealless Centrifugal Pumps for Petroleum, Heavy Duty Chemical, and Gas Industry Services

*ATEX : ATEX Directive (94/9/EC)

BUILDING BLOCK SYSTEM

NIKKISO Non-Seal® Pumps are only one in the world applying the building block system to the canned motor pumps. Wide interchangeabilities of pump modules and motor modules are available and these modules can be freely combined, so it is possible to minimize numbers of spare pumps, motors and numbers of parts in stocks. This also makes on site repair possible.

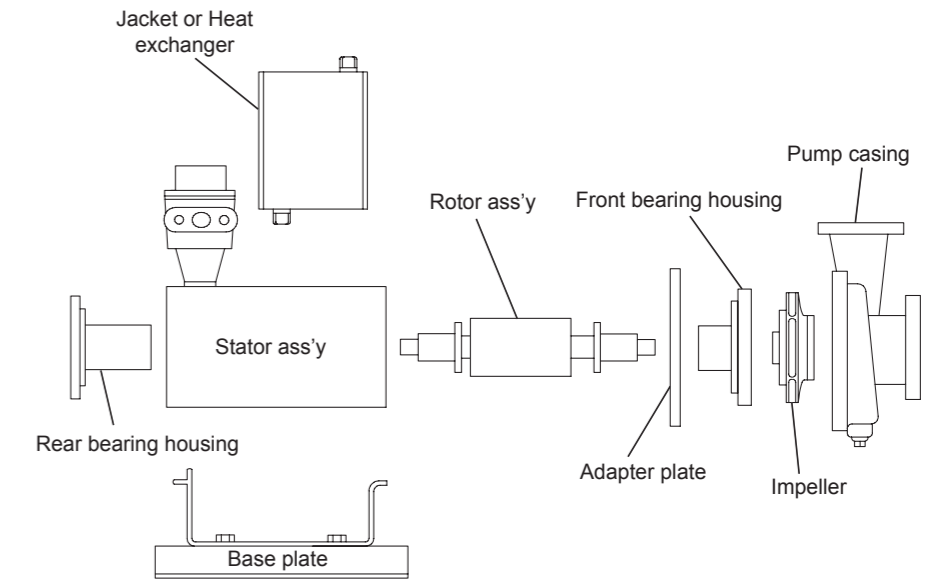

BEARINGS

An average bearing life in excess of 3 years has been achieved on over 70,000 units in operation. Over forty years of field experience combined with a broad range of materials and configurations to control bearing environment assures you of maximum bearing life in your application. The requirements for long bearing life are really quite simple.

Minimum Bearing Loads

NIKKISO Non-Seal® Pumps bearings are conservatively sized for light unit loading. Metal-to-metal rabbet fit construction assures precise alignment for uniform load distribution. Thrust loads are hydraulically balanced so that thrust bearings are normally unloaded.

Clean Fluid Flow to Bearings

Where severe solids content is present, the type HS configuration utilizes a clean external flush to assure a clean environment for the bearings.

Prevention of Solids Formation

Jacketed type pumps have been developed to heat or cool the bearing circulation flow when handling fluids which polymerize, precipitate or have elevated melting temperatures.

A Choice of Bearing Materials

NIKKISO Non-Seal® pumps are available with a wide range of bearing materials matched to the specific requirements of your application. Carbon graphite materials are inert to most chemicals and provide good tolerance to abuse due to their self-lubricating characteristics. Silicone carbide provides superior wear resistance.

Silicon Carbide lined Graphite Bearings

NIKKISO Bearings are sliding bearings which are always provided with lubrication grooves. The wearing surface of these bearings is lined with a silicon carbide which is created by conversion of graphite using pure silicon. These bearings have a reduced sensibility to mechanical shocks and chipping compared with pure SiC. Embedded graphite particles provide emergency lubrication if the pump should accidentally run dry. It has nearly unlimited bearing life for all applications. The ideal match for Tungsten Carbide coated Stainless Steel shaft sleeves and thrust washers.

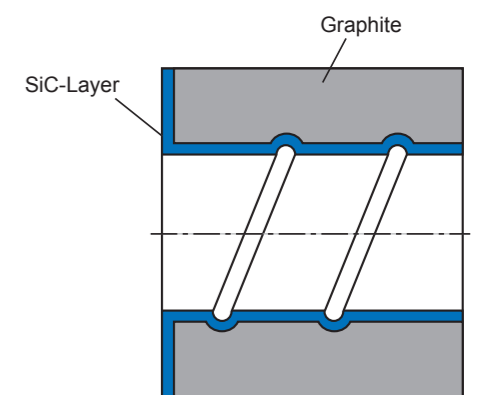

Complete Field Replaceable

All new wear surfaces are provided by replacement of shaft sleeves and thrust washers. Maintenance intervals remain predictable over the life of the pump.

OPTIONS



REMOTE INDICATOR

In addition to the local indicator of E Monitor a remote indicator including alarm and trip can be supplied. For this purpose a RS422, a 0 to 5 V, or a 4 to 20 mA signal is available.



DRY OPERATION PROTECTION (SAO RELAY)

Load current sensing relay protects the pump from dry operation on services such as truck/tank car unloading. It detects low load resulting from dry operation and provides for shutdown of the motor.



SEAL POT

Seal pot is available for type HM in order to supply flushing liquid to mechanical seal.



INDUCER

Inducer is available to low minimum net positive suction head requirements (NPSHR).



MECHANICAL BEARING MONITOR

The end of the monitor has a contact tip which is fitted within a cavity in the end nut on the rotor shaft. Clearances between the contact tip and the end nut correspond to the maximum allowable bearing wear. At maximum allowable bearing wear the tip is contacted and ruptured. In addition, the monitor is useful in detecting corrosion of the stator liner and rotor sleeve since the contact tip is supplied in the similar metallurgy by one-half the thickness of those components.

EXAMPLES

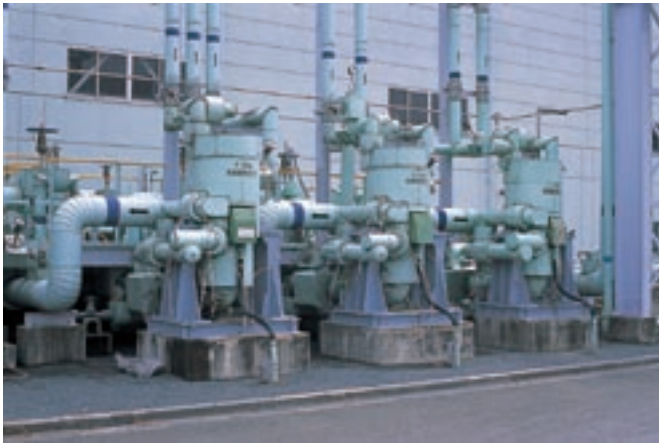

Reverse circulation type pumps for pumping LNG as Cooling medium. (Vertical type, Motor output 75kw)



High-temperature type pump in a chemical plant.



Self-priming type pumps in a paint manufacturing plant.



High melting point type pump in a chemical plant.



Basic type pumps in a water treatment plant. (Titanium casing & impeller)



Basic type pumps in a chemical plant.

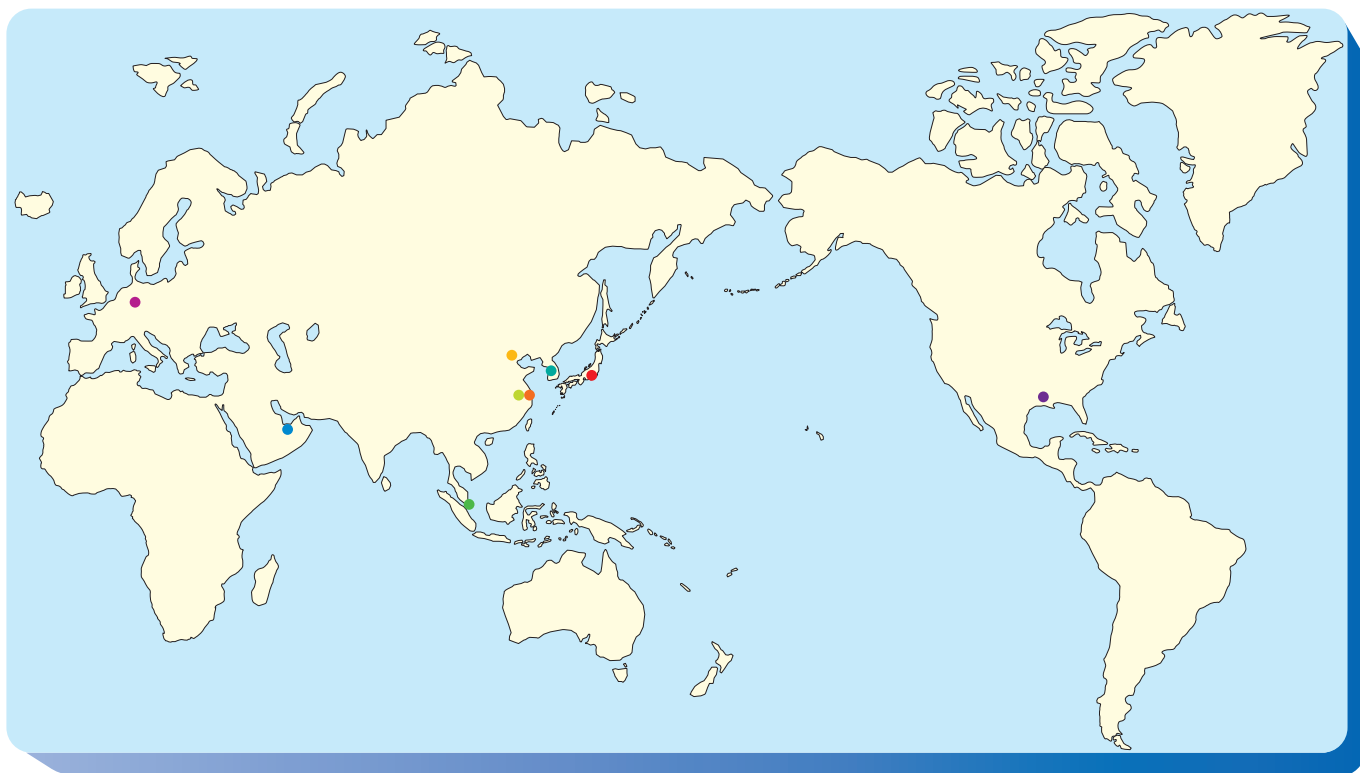

• NIKKISO CO., LTD.
FLUID TECHNOLOGIES UNIT

Head office • 43-2, Ebisu 3-Chome, Shibuya-ku, Tokyo 150-8677, Japan
 Telephone • +81-3-3443-3726
 Fax • +81-3-3444-2438
 Plant • Tokyo, Japan
 URL • <http://www.nikkiso.co.jp/english>

● NIKKISO Pumps America, Inc.

Office & Plant • 600 Kenrick Drive, Suite C-1, Houston, Texas 77060, U.S.A.
 Telephone • +1-281-310-6747
 Fax • +1-281-310-6771
 URL • <http://www.nikkisopumpsamerica.com>

● NIKKISO Pumps Europe GmbH

Office & Plant • Nikkiso Strasse, D-63674 Altenstadt 2, Germany
 Telephone • +49-6047-96490
 Fax • +49-6047-964999
 URL • <http://www.nikkiso-pumps.com>

● NIKKISO MIDDLE EAST Representative Office

Office • 7F-AI Yasat Tower-Baniyas Street, P. O. Box97, Abu Dhabi, UAE
 Telephone • +971-4-265-9979
 Fax • +971-4-265-9980

● NIKKISO Pumps Korea Ltd.

Office • 603 IL Shin B/D 541 Dowha-Dong, Mapo-Gu, Seoul, Korea
 Telephone • +82-2-719-1446
 Fax • +82-2-719-1440

● Shanghai NIKKISO Non-Seal Pump Co., Ltd.

Office & Plant • No. 1795, Huhang Road, Nanqiao Town, Fexian District, Shanghai 201400, P.R.C.
 Telephone • +86-21-6710-3258
 Fax • +86-21-6710-3250
 URL • <http://www.shnikkisopump.com/>

● NIKKISO Shanghai Service Center

Office • Friendship Building, Shanghai Petrochemical Complex, Shanghai, P.R.C.
 Telephone • +86-21-5794-1325
 Fax • +86-21-5794-1948

● NIKKISO Beijing Representative Office

Office • Room 3201, Jing Guang Center, Hu Jia Lou, Chao Yang Qu, Beijing, P.R.C.
 Telephone • +86-10-6597-3011
 Fax • +86-10-6597-3012

● NIKKISO Singapore Representative Office

Office • 101 Cecil Street, Units #18-11 Tong Eng Building, Singapore 069533
 Telephone • +65-6221-1235
 Fax • +65-6221-3244

- NIKKISO accepts no liability for any errors it contains, and reserves the right to alter specifications without notice.
- Product (s) (including parts, technical data or information thereto) described in this catalog shall be subject to export control laws and regulations of Japan or the US. You need to obtain the appropriate government (s) when you export if such laws and regulations require.
- "NIKKISO NON-SEAL" is registered in Japan, USA, Canada, Mexico, EU, Korea, Taiwan and other major countries.