

Pump Performance Chart

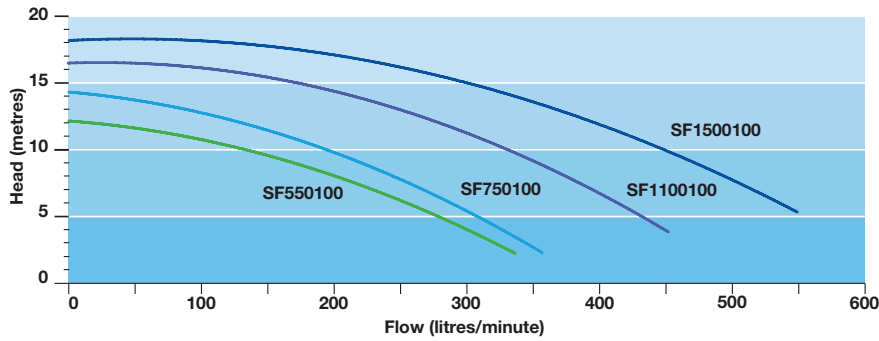

Disclaimers Every endeavour has been made to publish the correct details in this leaflet. No responsibility will be taken for errors, omissions or changes in product specifications. All performance data taken at sea level.

Motor

Type:	TEFC 2 pole
Thermal overload:	Internal, automatic reset
Temperature rise:	Class F
Voltage:	230V +/- 10%
Frequency:	50Hz

Suitable for pumping clean non-aggressive liquids without solids or fibres in suspension.

Materials

Component	Material
Pump Casing	Reinforced Polypropylene 40% Glass Filled
Impeller	Polyphenylene Ether
Diffuser	Polypropylene HP TF 40%
Yoke	Polypropylene 40% Glass Filled
Drain plugs	Polypropylene
Motor shaft	SS 303
End shield	Cast Aluminium
Strainer basket	High Impact Polystyrene
Strainer basket o-ring	Low friction nitrile
Strainer pot lid	Makrolon Polycarbonate
Barrel unions	Acrylonitrile Butadiene Styrene (ABS)
Base	Copolymer Polypropylene
Seal bellows	Nitrile
Seal stationary face	Aluminium oxide
Seal rotating face	Carbon
Seal Spring	SS 316
Cord/Plug	Approved to AS/NZS 3112

Line Drawings

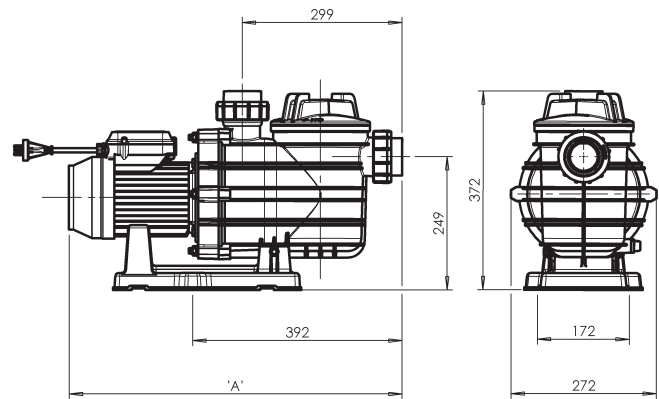

Dimension Table

Pump Model	SF550	SF750	SF1100	SF150
A	595	595	610	650

Unless otherwise specified, all dimensions in mm.
Fixing holes accept 12mm fasteners.

Model Data

Pump Model	Motor power		Supply Voltage	Phase	Full Load current	Locked Rotor current	Capacitor	Thermal protection cutout	Insulation class	Speed (2 pole)
Abbreviation	P1	P2			FLA	LRA				
Unit of Measure	Watt	Watt	V	n	Amp	Amp	µF	°C		rpm
SF550100	580	400	230	1	2.6	14	25	150	F	2800
SF750100	690	485	230	1	3.0	14	25	150	F	2800
SF1100100	1020	715	230	1	4.5	22	25	150	F	2800
SF1500100	1540	1075	230	1	6.7	28	30	150	F	2800

Pump Model	Run coil resistance	Start coil resistance	Sound Pressure Level	IP Rating	Bearing type	Bearing temperature rating	Max Working temp	Max water temp	Min water temp	Max working pressure
Abbreviation			SPL							
Unit of Measure	Ohms	Ohms	dB(A)			°C	°C	°C	°C	kPa
SF550100	4.64	5.69	56	IP55	6203	120	50	35	5	360
SF750100	4.64	5.69	56	IP55	6203	120	50	35	5	360
SF1100100	3.22	5.69	59	IP55	6203	120	50	35	5	360
SF1500100	1.99	3.78	61	IP55	6203	120	50	35	5	360

Distributor Catalogue. Commercial in confidence. Pentair Water Pty Ltd account customers only.

© information contained here-in remains the property of Pentair Water Pty Ltd. Any reproduction, display, publication, modification or distribution is strictly prohibited without the prior written permission of Pentair Water Pty Ltd.

Disclaimer Every endeavour has been made to publish the correct details in this data sheet. No responsibility will be taken for errors, omissions or changes in product specifications. Pentair Water reserves the right to change specifications