

serie



ULTRA



ULTRA 18

электронасосы
многоступенчатые

MULTICELLULAIRES

ELECTROPOMPS

MULTICELULARES

ELECTROBOMBAS

ELECTRIC PUMPS

MULTISTAGE

67



ХАРАКТЕРИСТИКИ / CHARACTERISTICS / CARACTERISTICAS / CARATERISTIQUES



ПРИМЕНЕНИЕ – многоступенчатый горизонтальный центробежный насос из нержавеющей стали. Перекачивание чистой без примесей жидкости в частном, сельскохозяйственном и промышленном секторе; системы повышения давления; ирригация; питьевая и гликолевая вода; водоочистительные системы; пищевая промышленность; системы отопления и кондиционирования воздуха; моечные системы.

ПРЕИМУЩЕСТВА – моноблочная компактная конструкция; бесшумность; превосходные показатели продуктивности, позволяющие значительно снизить эксплуатационные расходы и затраты энергии; экономичность; превышающие стандартные габариты подшипники для долговечности в эксплуатации; промежуточная направляющая вала для обеспечения соосности вращения.

ОСОБЕННОСТИ КОНСТРУКЦИИ – пропускная способность: до 26 м³/h; суммарная высота напора: до 78 м; максимальное рабочее давление: 8 bar (9 bar с 7 рабочими колесами); температурная зона жидкости: от +5 до +35 °C; температура окружающей среды: до 40 °C.

ДВИГАТЕЛЬ - двухполюсный асинхронный электродвигатель; однофазные модели – 230V – 50 Hz с тепловой защитой до P2= 1,85 Kw; трехфазные модели – 230/400V – 50 Hz; изоляция класса F; степень защиты IP 44.

МАТЕРИАЛЫ – корпус, кольцо герметизирующего уплотнения – хромоникелевая сталь AISI 304; рабочие колеса, диффузоры - Noryl® с добавлением стекловолокна (GFN2V); вал привода насоса - хромоникелевая сталь AISI 303; опора двигателя - алюминиевый сплав; герметизирующее уплотнение – графитокерамика до 6 ступеней, графит-кремний – начиная с 7 ступеней; промежуточная направляющая вала – латунь - хромоникелевая сталь AISI 304.

USES - Stainless steel multistage horizontal pumps. Pumping of clean non-loaded fluids in the domestic, agricultural and industrial sectors; pressurizing systems; irrigation; drinking and glycol water; water treatment; food industry; heating and air conditioning; washing system.

ADVANTAGES - Closed coupled and compact; silent; excellent efficiency that allows a reduction of running cost ad powers; economical; over-dimensioned bearings for longer life of the machines; intermediate shaft guiding stage for concentricity of rotation.

CONSTRUCTION FEATURES - Capacity: up to 26 m³/h; total Head: up to 78 m.; maximum working pressure: 8 bar (9 bar with 7 impellers); maximum suction Head up to; maximum liquid temperature: from +5 up to +35 °C; ambient temperature: max 40 °C.

MOTOR - 2 Pole induction Motor; single Phase 230V - 50Hz with thermal protector up to P2= 1,85 Kw; Three Phase 230-400V - 50 Hz; insulation class F; protection degree IP 44.

CONSTRUCTION FEATURES - Pump body, mechanical seal disc holder: chromo-nickel steel AISI 304; impellers, diffusers: Noryl® reinforced with fiber glass (GFN2V); pump shaft: AISI 304 chromo-nickel steel; motor bracket: aluminum alloy; mechanical seal: ceramic-graphite up to 6 stages - graphite-silicon carbide from 7 stages; intermediate shaft guiding stage bush: brass-AISI 304 chromo-nickel steel.

UTILIZACIONES - Bombas centrífugas multietapas horizontales con cuerpo bomba en acero cromo-níquel Aisi 304. Bombeo de líquidos química y mecánicamente no agresivos en el sector doméstico, agrícola e industria; sistemas de presurización; riegos; agua potable o con glycol; tratamientos del agua; industria alimenticia; calefacción y refrigeración; sistemas de lavado.

VENTAJAS - Versión monobloc compacta con medidas reducidas; extrema silenciosidad de funcionamiento; excelente rendimiento con desminución de los costes de ejercicio y de las potencias; económica; cojinetes del motor sobredimensionados para una mayor duración; cojinete intermedio guía-eje que garantiza la coaxialidad de rotación.

CARACTERÍSTICAS CONSTRUCTIVAS -Caudal hasta los 26 m³/h; prevalencia hasta los 78 mt.; maxima presión de ejercicio 8 bar (9 bar con 7 rodetes); temperatura de ejercicio del líquido bombeado: de +5 a +35 °C; temperaturata del ambiente max 40°C.

MOTOR - Motor de 2 polos a inducción; monofasico 230v-50hz dotado de protección térmica hasta P2= 1,85 Kw; Trifasico 230/400v-50hz; aislamiento clase F; protección IP44.

MATERIALES - Cuerpo bomba,disco sello mecánico: acero cromo-níquel AISI 304; rodetes, difusores: Noryl® reforzado con fibra de vidrio (GFN2V); eje: acero cromo-níquel AISI 303; soporte motor: aluminio estampado; sello mecánico: cerámica-grafito hasta los 6 estadios - grafito-carburo de silicio de los 7 estadios; cojinete intermedio guía-eje: latón-acero cromo-níquel AISI 304.

UTILISATION - Pompes multicellulaires horizontales en acier inox. Pour le pompage d'eaux propres non chargées pour des applications domestiques, agricoles, industrielles; groupes de surpression; irrigation; eau potable ou solution de glycol; traitement des eaux; industrie alimentaire; chauffage et Climatisation; stations de lavage auto.

AVANTAGES - Version monobloc compact; silencieux; rendement excellent avec une diminution remarquable des coût de fontionnement et des puissance; économique; roulements surdimensionnés et étage de guidage intermédiaire pour une durée de vie prolongée des machines; roulement intermédiaire étage de guidage qui garantie le coaxialité de rotation.

CARACTÉRISTIQUES D'EXÉCUTION - Débit jusqu'à 26 m³/h; hauteur jusque'à 78 m.; pression max. de fonctionement 8 bar (9 bar avec 7 roues); température du liquide pompé: de +5 à +35 °C; température ambiante max 40 °C.

MOTEUR - Moteur 2 pôles à induction; monophasé 230 V – 50 Hz avec protection thermique jusqu'à P2=1,85 Kw; triphasé 230/400 V – 50 Hz; isolation en classe F; degré de protection IP 44.

MATERIAUX - Corps de pompe, disque porte-garniture: acier au chrome-nickel AISI 304; roues, diffuseurs: Noryl® renforcé avec fibre de verre (GFN2V); arbre: acier au chrome-nickel AISI 303; support moteur: alliage d'aluminium; garniture mécanique: céramique – graphite jusqu'à 6 étages, graphite - carbure de silicium à partir de 7 étages; douilles étage de guidage intermédiaire: laiton-acier au chrome-nickel AISI 304.

serie

ULTRA

электронасосы
МНОГООРУПЕНЧАТЫЕ



ULTRA 5



ULTRA 9



ULTRA 7



ULTRA 3

■ ■ ■ U 5 - 120 / 4 T

- Трехфазные - Three-phase
- Количество рабочих колес - no. of impellers
- Номинальная мощность HPx100 - Nominal Power HPx100
- Номинальная пропускная способность m³/h - Nominal flow-rate m³/h
- Модель - Type **ULTRA**

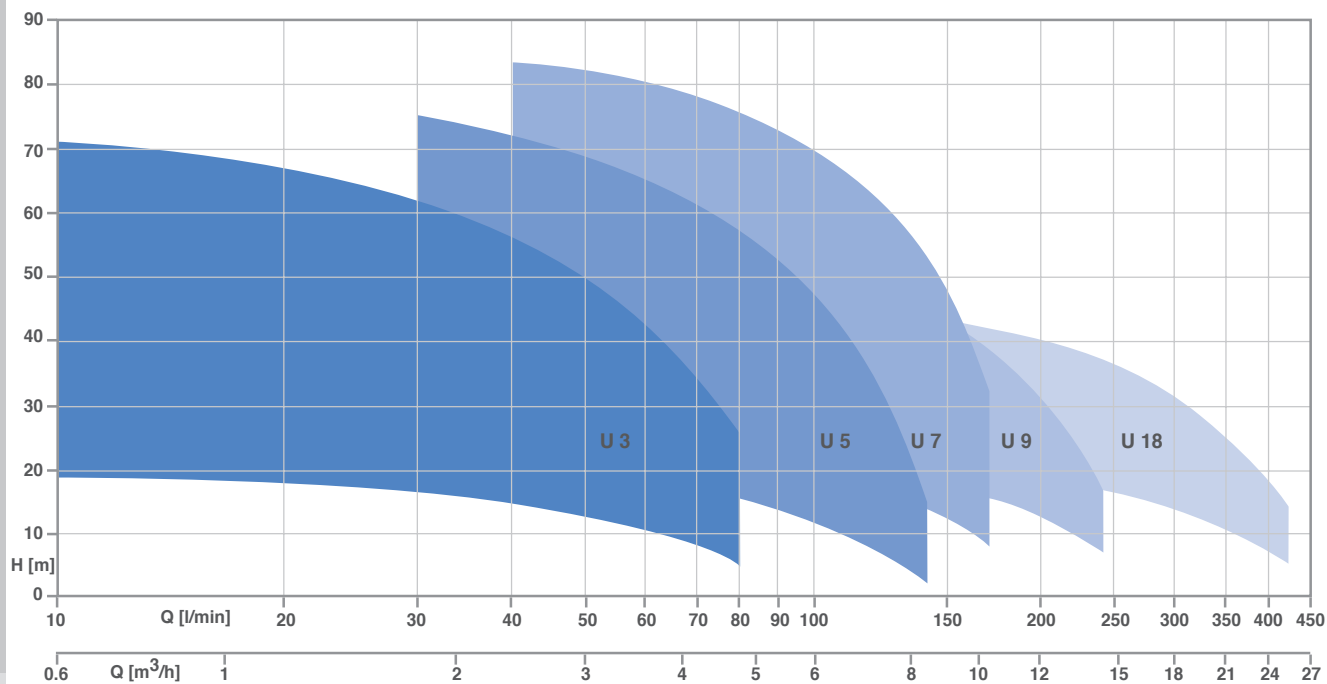

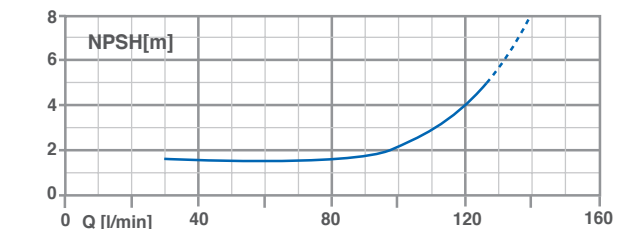
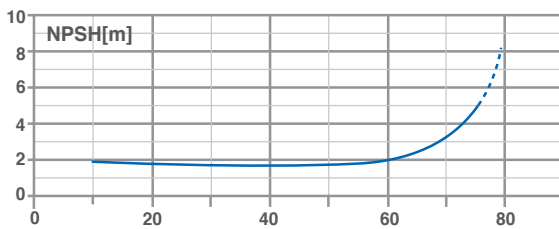
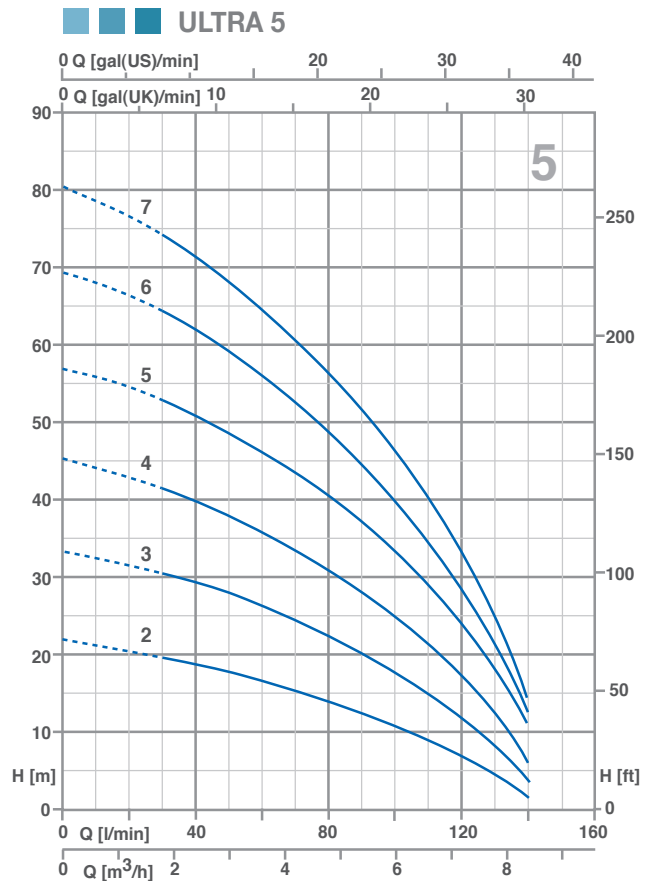
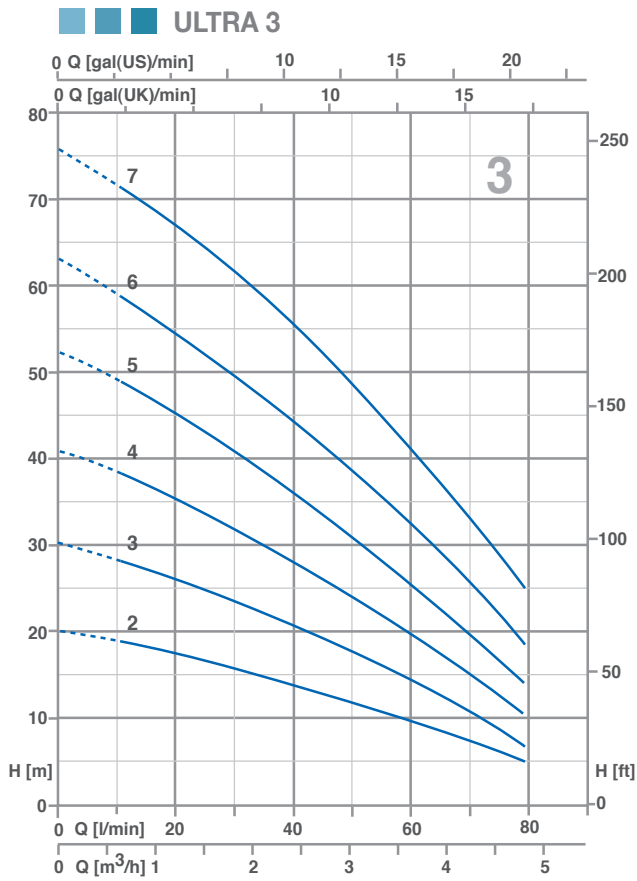

ТЕХНИЧЕСКИЕ ДАННЫЕ / Technical data / Datos técnicos / Données techniques

МОДЕЛЬ / TYPE / MODELO / MODÈLE		P2		P1 (kW)		AMPERE		Q (m³/h - l/min)							
1~	3~	(HP)	(kW)	1~	3~	1~	3~	0	0.6	1.2	1.8	2.4	3.6	4.8	
230 V - 50 Hz	230 / 400 V - 50 Hz					1x230V 50Hz	3x400V 50Hz	0	10	20	30	40	60	80	
U 3-50/2	U 3-50/2 T	0.5	0.37	0.45	0.46	2	0.9	20.2	18.8	17.3	15.3	13.7	9.5	4.9	
U 3-70/3	U 3-70/3 T	0.7	0.51	0.65	0.63	2.9	1.2	30	27.9	25.4	23	20.3	14	6.7	
U 3-90/4	U 3-90/4 T	0.9	0.66	0.9	0.88	4	1.8	40.8	38.3	35.1	31.8	27.9	19.8	10.4	
U 3-100/5	U 3-100/5 T	1	0.75	1.06	1.01	4.8	1.9	52.2	48.9	45.1	40.8	36	25.4	14	
U 3-120/6	U 3-120/6 T	1.2	0.9	1.23	1.23	5.6	2.6	62.8	58.7	54.5	49.6	43.9	32.1	18.3	
U 3-150/7	U 3-150/7 T	1.5	1.1	1.54	1.45	7.1	2.9	75.5	71.3	66.6	61.2	54.8	41.1	24.9	

МОДЕЛЬ / TYPE / MODELO / MODÈLE		P2		P1 (kW)		AMPERE		Q (m³/h - l/min)							
1~	3~	(HP)	(kW)	1~	3~	1~	3~	0	1.8	2.4	3.6	4.8	6	7.2	8.4
230 V - 50 Hz	230 / 400 V - 50 Hz					1x230V 50Hz	3x400V 50Hz	0	30	40	60	80	100	120	140
U 5-70/2	U 5-70/2 T	0.7	0.51	0.61	0.58	2.7	1.1	22	19.7	18.7	16.6	14	10.8	6.8	1.8
U 5-80/3	U 5-80/3 T	0.8	0.6	0.86	0.79	3.9	1.5	33.4	30.3	29	26	22.5	17.6	12	3.9
U 5120/4	U 5-120/4 T	1.2	0.9	1.13	1.13	5.2	2.5	45.3	41.3	39.6	35.6	30.8	24.9	17.6	6.4
U 5-150/5	U 5-150/5 T	1.5	1.1	1.47	1.39	6.8	2.8	56.8	53	51	46.1	40.1	33.3	24.8	11.5
U 5-180/6	U 5-180/6 T	1.8	1.3	1.7	1.62	7.7	3	69.3	64.4	62	55.6	48.2	39.6	28.8	12
U 5-200/7	U 5-200/7 T	2	1.5	2	1.86	9	3.4	80.3	73.6	71	64.5	56.1	46	33.4	12.5

ULTRA 7

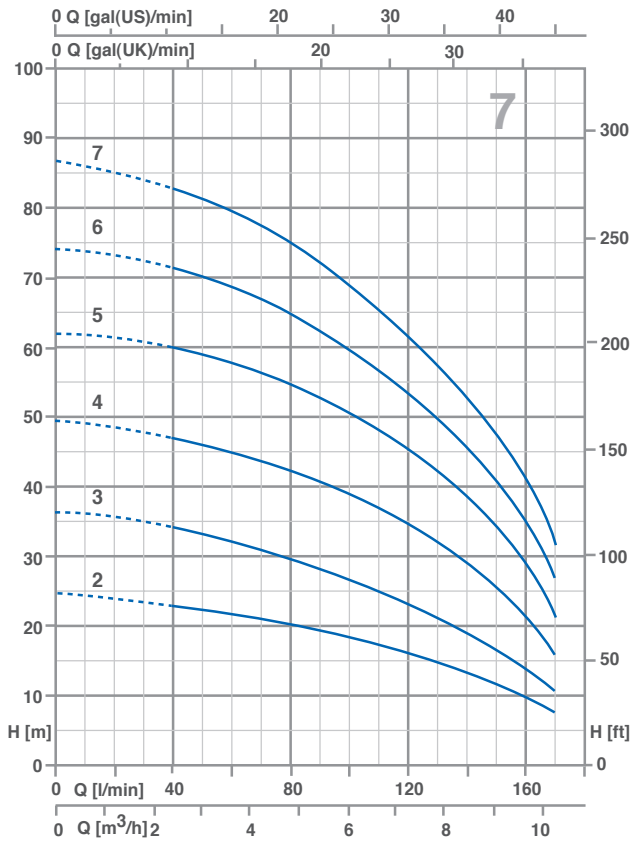

ULTRA 9

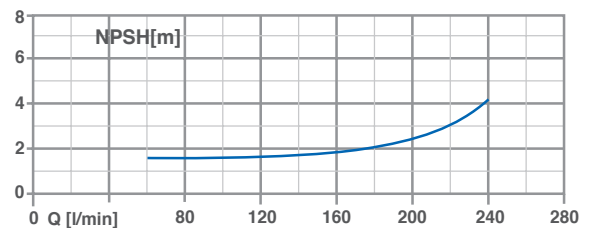
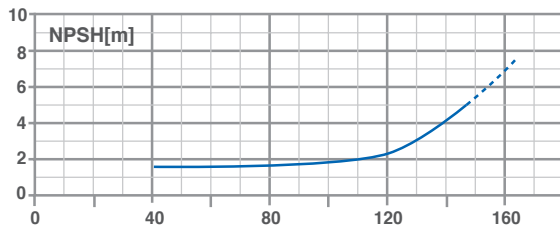
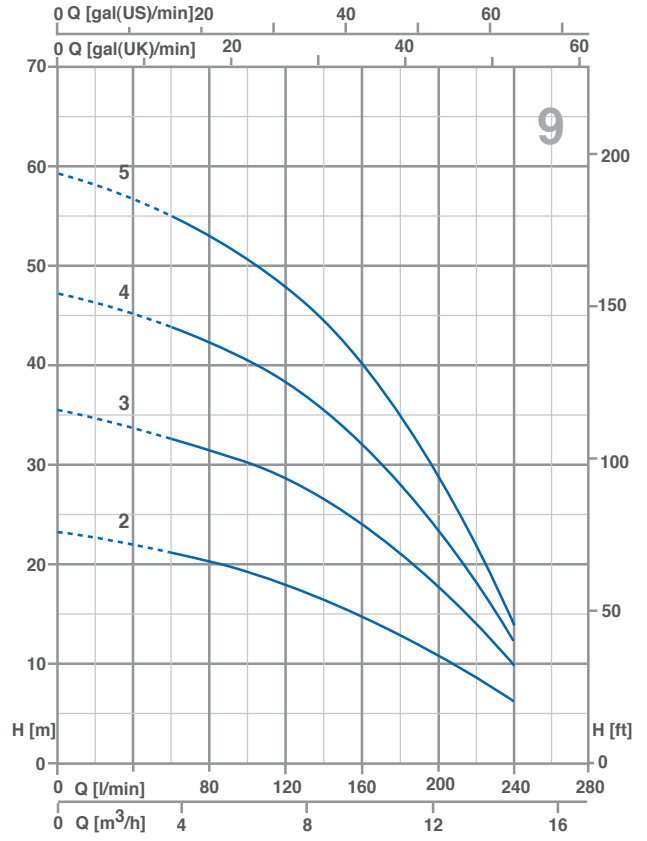

ТЕХНИЧЕСКИЕ ДАННЫЕ / Technical data / Datos técnicos / Données techniques

МОДЕЛЬ / TYPE / MODELO / MODÈLE		P2		P1 (kW)		AMPERE		Q (m³/h - l/min)									
1~	3~	(HP)	(kW)	1~	3~	1~	3~	H (m)									
								0	2.4	3.6	4.8	6	7.2	8.4	9.6	10.2	
230 V - 50 Hz		230 / 400 V - 50 Hz				1x230V 50Hz	3x400V 50Hz	0	40	60	80	100	120	140	160	170	
U 7-100/2	U 7-100/2 T	1	0.75	0.97	0.9	4.4	1.7	24.8	23.4	22	20.5	18.7	16.3	13.6	10.2	8.3	
U 7-120/3	U 7-120/3 T	1.2	0.9	1.32	1.3	5.9	2.6	36.7	34	32	29.6	26.5	23	18.6	13.8	11	
U 7-180/4	U 7-180/4 T	1.8	1.3	1.83	1.71	8.3	3.2	49.5	47.4	45.3	42.5	39.2	34.8	29.4	22.6	16.9	
U 7-250/5	U 7-250/5 T	2.5	1.85	2.39	2.15	10.9	4.2	62.6	60.6	58.2	55.1	51.1	45.8	39	29.8	21.5	
U 7-300/6	U 7-300/6 T	3	2.2	2.68	2.63	12.2	5	74.8	71.5	68.3	64.5	59.3	53	44.6	34.5	26.7	
-	U 7-350/7 T	3.5	2.57	-	3.04	-	5.5	87.2	83.3	79.3	74.6	68.9	61.9	52.5	41	32.2	

МОДЕЛЬ / TYPE / MODELO / MODÈLE		P2		P1 (kW)		AMPERE		Q (m³/h - l/min)											
1~	3~	(HP)	(kW)	1~	3~	1~	3~	H (m)											
								0	3.6	4.8	6	7.2	8.4	9.6	10.8	12	13.2	14.4	
230 V - 50 Hz		230 / 400 V - 50 Hz				1x230V 50Hz	3x400V 50Hz	0	60	80	100	120	140	160	180	200	220	240	
U 9-100/2	U 9-100/2 T	1	0.75	0.98	0.92	4.4	1.7	23	20.9	20	19.1	17.9	16.6	15	13.2	11.1	8.9	6.5	
U 9-150/3	U 9-150/3 T	1.5	1.1	1.43	1.38	6.7	2.8	35.2	32.6	31.5	30.3	28.8	26.9	24.5	21.5	18.3	14.7	10.8	
U 9-200/4	U 9-200/4 T	2	1.5	1.88	1.77	8.4	3.3	47.1	43.5	42	40.5	38.3	35.7	32.4	28.4	23.8	18.9	13.3	
U 9-250/5	U 9-250/5 T	2.5	1.85	2.32	2.18	10.6	4.3	59.2	54.4	52.4	50.4	47.9	44.8	40.5	35.5	29.8	23.5	16.3	

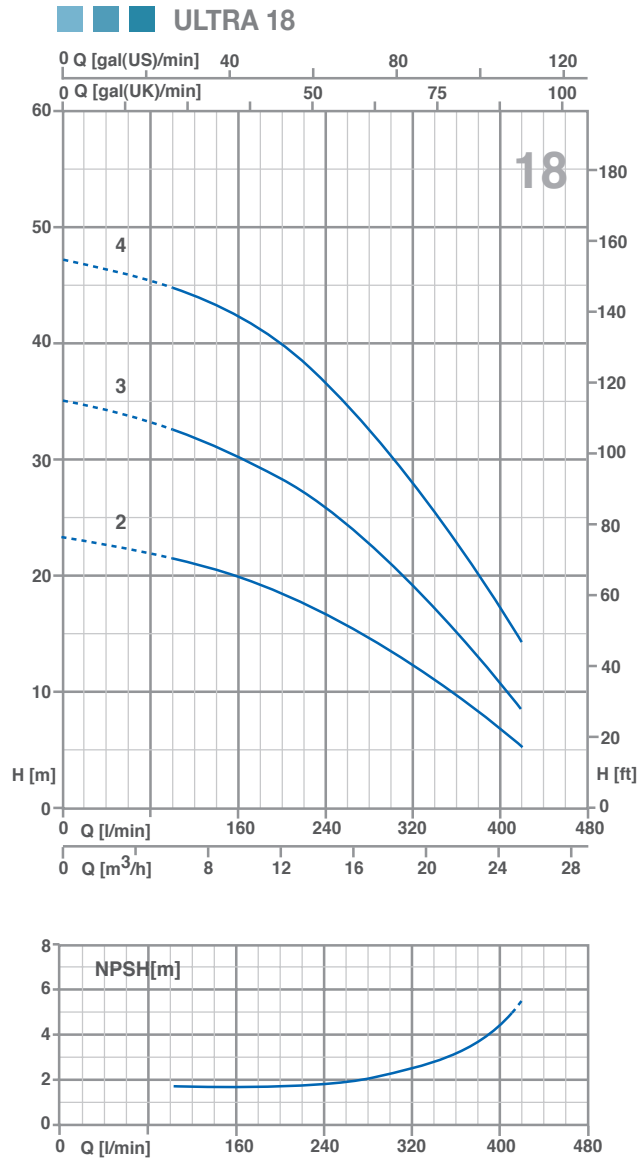

ТЕХНИЧЕСКИЕ ДАННЫЕ / Technical data / Datos técnicos / Données techniques

МОДЕЛЬ / TYPE MODELO / MODÈLE	P2		P1 (kW)	AMPERE	Q (m³/h - l/min)																	
				3~	0	6	7.2	8.4	9.6	10.8	12	13.2	14.4	15.6	16.8	18	19.2	20.4	21.6	22.8	24	25.2
				3~	0	100	120	140	160	180	200	220	240	260	280	300	320	340	360	380	400	420
230 / 400 V - 50 Hz	(HP)	(kW)	3~	3x400V 50Hz	H (m)																	
U 18-180/2 T	1.8	1.3	1.52	3	23.1	21.4	21	20.5	19.9	19.2	18.4	17.6	16.7	15.7	14.7	13.5	12.1	10.9	9.7	8.3	7	5.5
U 18-250/3 T	2.5	1.85	2.19	4.3	35	32.7	32.2	31.4	30.5	29.5	28.3	26.7	25.5	24.3	22.8	21.2	19.3	17.3	15.1	12.9	10.8	8.7
U 18-400/4 T	4	3	2.99	5.5	47.2	44.6	44.1	43.3	42.4	41.2	40	38.5	36.7	34.9	32.9	30.5	27.9	25.3	22.7	20	17.1	14.3

ULTRA 3 - ULTRA 5

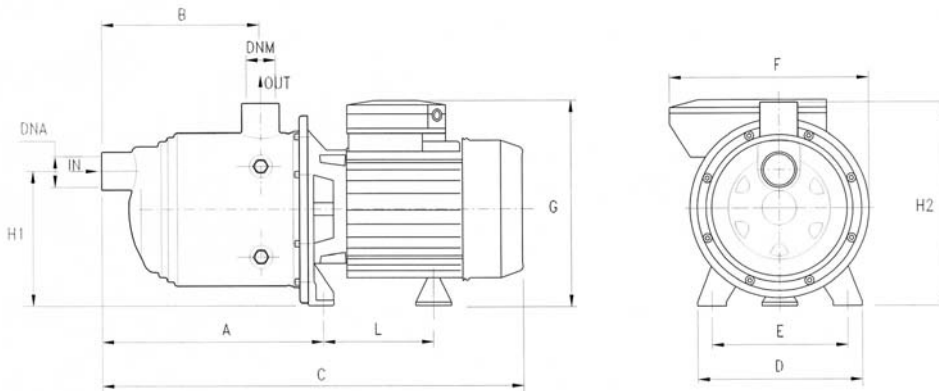

МОДЕЛЬ / TYPE MODELO MODÈLE	РАЗМЕРЫ / Dimensions / Dimensiones / Dimensions (mm)										DNA	DNM
	A	B	C	D	E	F	G	L	H1	H2		
U 3-50/2	166.8	103	333	164	140	178	195	93.7	128	192	1" G	1" G
U 3-70/3	166.8	103	333	164	140	178	195	93.7	128	192		
U 3-90/4	190.8	127	357	164	140	178	195	104.7	128	192		
U 3-100/5	214.8	151	404	164	140	178	203	104.7	128	192		
U 3-120/6	238.8	175	428	164	140	178	203	104.7	128	192		
U 3-150/7	262.8	199	483	164	140	201	211	104.7	128	198		
U 5-70/2	166.8	103	333	164	140	178	195	93.7	128	192		
U 5-80/3	166.8	103	357	164	140	178	203	93.7	128	192		
U 5-120/4	190.8	127	380	164	140	178	203	104.7	128	192		
U 5-150/5	214.8	151	436	164	140	201	211	128.2	134	198		
U 5-180/6	238.8	175	459	164	140	201	211	128.2	134	198		
U 5-200/7	262.8	199	483	164	140	201	211	128.2	134	198		

ULTRA 7 - ULTRA 9 - ULTRA 18

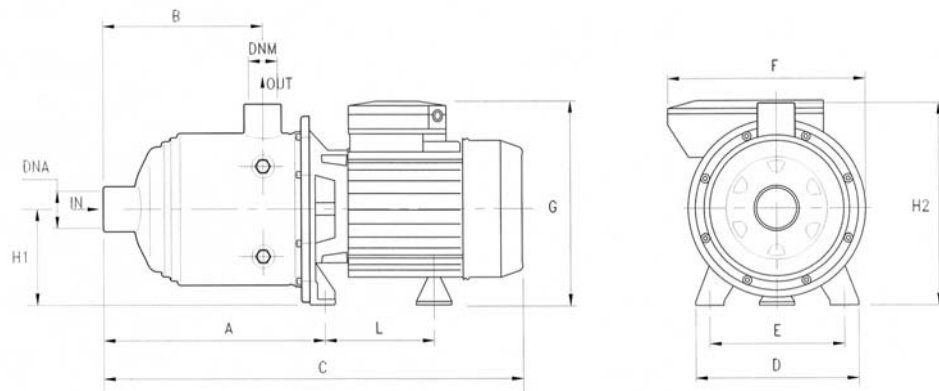

МОДЕЛЬ / TYPE MODELO MODÈLE	РАЗМЕРЫ / Dimensions / Dimensiones / Dimensions (mm)										DNA	DNM
	A	B	C	D	E	F	G	L	H1	H2		
U 7-100/2	166.8	103	356	164	140	178	203	93.7	92	192	1"1/4 G	1" G
U 7-120/3	166.8	103	356	164	140	178	203	93.7	92	192		
U 7-180/4	190.8	127	411	164	140	201	211	128.2	98	198		
U 7-250/5	214.8	151	436	164	140	201	211	128.2	98	198		
U 7-300/6	238.8	175	459	164	140	201	211	128.2	98	198		
U 7-350/7	262.8	199	527	164	140	201	230	148.2	103	203		
U 9-100/2	185.8	122	375	164	140	176	203	104.7	92	192	1"1/2 G	1"1/4 G
U 9-150/3	185.8	122	375	164	140	201	211	128.2	98	198		
U 9-200/4	216	152	436	164	140	201	211	128.2	98	198		
U 9-250/5	246	182	464	164	140	201	211	128.2	98	198		
U 18-180/2 T	201	137	432	164	140	201	211	128.2	98	198	2" G	1"1/2 G
U 18-250/3 T	238.5	174.5	432	164	140	201	211	128.2	98	198		
U 18-400/4 T	276	212	514	164	140	201	230	148.2	103	203		