

Plenty



U2000

U2000 - Variable Flow Vane Pumps

PlentyMirrlees

LUBRICANTS BLENDING

U2000



U2000 Pump with Gas Loaded Constant Pressure Control pumping Lube Oil to drum filling machine.

- BASE OIL TRANSFER
- SHEAR SENSITIVE ADDITIVES
- TANK RECIRCULATION BLENDING
- BLENDED OIL TRANSFER
- GREASE
- TRUCK LOADING
- BARGE LOADING
- DRUM FILLING
- BOTTLE/CAN FILLING MACHINES

Liquid products ranging in viscosities from 30 ssu to 350,000 ssu are handled with a U2000 vane pump, with mechanical seals used for most applications.

■ Standard pumps - heavy duty industrial

The U2000 standard pumps are built of S.G. iron (ductile iron) or steel case construction according to clients preference, and can be fitted with integral relief valve, and heating jackets as necessary for the duty.

■ API 676, and other specifications

The U2000 Pumps can be supplied in accordance with the requirements of API 676. Other international pump standards, or client specific requirements can be accommodated.

■ Unitisation

Pumps can be supplied as bare shaft or fully assembled with driver on a baseplate (API or Industrial design), with spacer or non-spacer coupling, and non-spark guard.

BITUMEN & ASPHALT

VARIABLE FLOW VANE PUMPS



U2000 with Electro Pneumatic actuator flow control including heat shield for Hot Bitumen transfer duty.

- TANK TO TANK TRANSFER
- IN-LINE BLENDING
- TRUCK LOADING
- BARGE LOADING
- DRUM FILLING
- BITUMEN EMULSION
- ORIMULSION
- STANDARD CONSTRUCTION UP TO 570°F

The Plenty rotary vane pump is able to perform continuous pumping during temperature changes where centrifugal pumps normally fail. For applications up to 390°F it is normal to use an internal bearing pump with only 1 mechanical seal. (2 seals on higher temp external bearing pumps).

VISCOUS FLUIDS



U2000 with Electro Actuator Flow control.

- POLYMERS
- RESINS
- ADHESIVES
- HEAVY FURNACE OILS
- MOLASSES*
- EDIBLE OILS
- VARNISH
- INKS
- DISTILLATE FUELS

*For massecuite duty, see Magmo Pump Range

Viscous fluids up to 350,000 ssu are handled with a standard pump, and viscosities in excess of 2,000,000 ssu with a factory modified pump and sealing arrangement.

■ Non standard pumps

The U2000 pump design can be factory modified for extremely viscous, or arduous refinery, applications. Materials of construction are selected according to the fluid nature.

■ Specialist Sealing

Special sealing options are available including single, double and tandem arrangements, in component or cartridge configuration.

■ Sealless Magnetic Drive

When single or double mechanical seals are not able to provide a safe seal arrangement then a U2000 pump with magnetic drive should be selected.

CHEMICAL

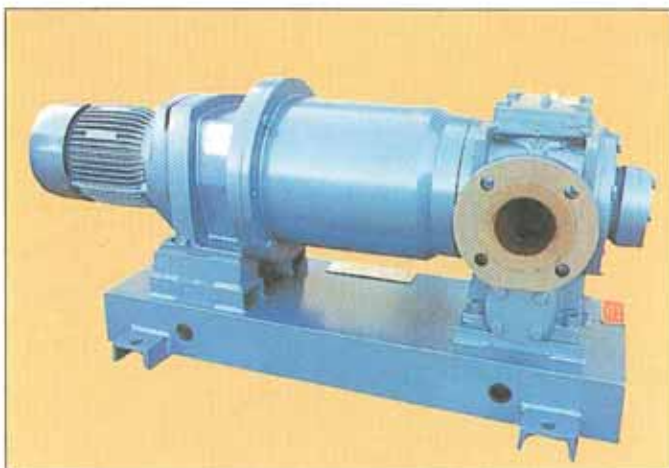

Fixed capacity U2000 Pump with high torque Magnetic Drive for hazardous chemical transfer.

- FATTY ACIDS
- VISCOUS CHEMICAL ADDITIVES
- ACETATE DOPE
- VISCOSE
- POLYMERS
- RESINS
- SOAPS / SOAP STOCKS
- POLYOLS

Materials of construction range from basic Cast Iron / Steel, to NI-Resist, Bronze and Stainless Steel Alloys, to ensure compatibility with the fluid to be pumped.

U2000

VARIABLE FLOW VANE PUMPS

WHY CHOOSE THE U2000?

Energy costs are increasing and will become an even greater burden to the profitability of your company.

Refer to the graph and see how the U2000 pump with its variable flow capability can reduce your energy costs.

The U2000 can vary its flow infinitely between zero and 100% flow. As power absorbed is pro-rata to flow, it can be seen that reducing flow will reduce the hydraulic horsepower.

A conventional positive displacement pump can only vary its flow between zero and 100% by means of spillback of excess flow. As the percentage of flow bypassed increases the hydraulic horsepower increases as a result of pressure accumulation from the spillback valve or relief valve, and return pipework.

- POWER SAVINGS OF UP TO 120% CAN BE ACHIEVED AT REDUCED FLOWS.
- PUMPS THAT HAVE A REGULAR INTERMITTENT DEMAND CAN ACTUALLY PAY BACK THEIR INITIAL CAPITAL COST AND RETURN A PROFIT FROM ENERGY SAVINGS.

VARIABLE FLOW VANE PUMPS

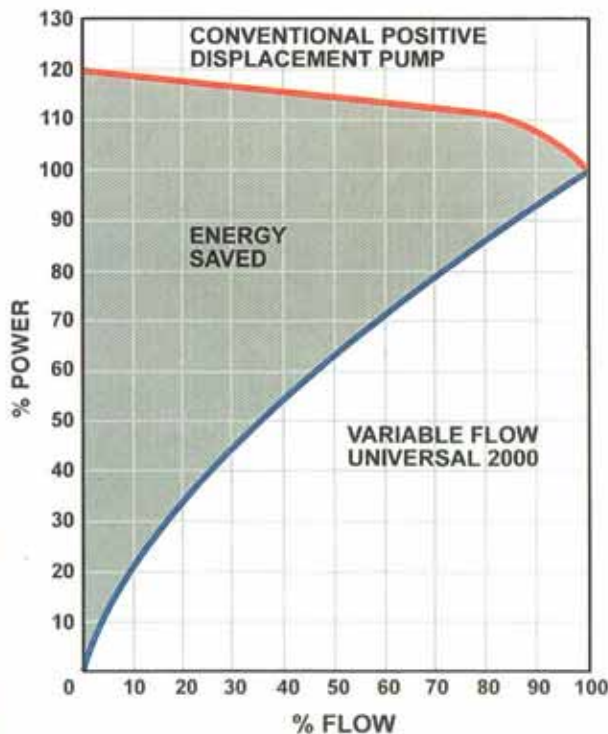

Energy Conservation Graph

MANUAL CONTROL PUMPS

Manual control pumps have their inner bodies connected to a hand wheel via the control spindle. Flow control between zero and maximum is achieved by rotating the hand wheel which changes the position of the inner bodies altering the eccentricity of the rotors to the shaft, thereby changing the flow rate. The hand wheel is equipped with an indicator calibrated in % eccentricity to facilitate easy setting within 1% accuracy. Flow can also be reversed and controlled between zero and maximum in the reverse direction.

Advantages

- Flow control and reversal is achieved at constant shaft speed and direction of rotation. This means that there is no need for costly variable speed gear boxes or flow control valves that would be necessary in systems not incorporating Plenty manual control pumps. The zero flow position means that the whole system can be interrupted whilst the pump is running.

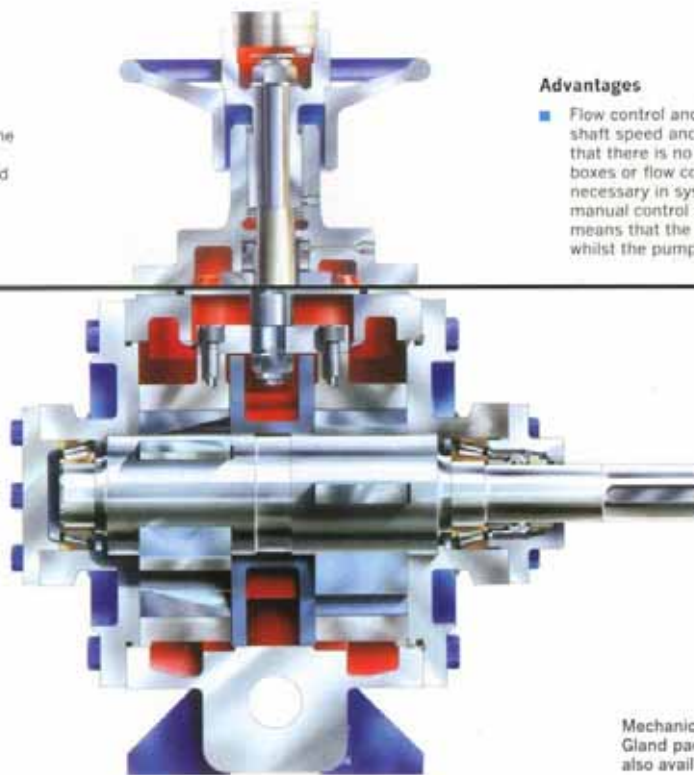

Inboard Pump

Bearings operate in fluid being pumped.
Suitable for all lubricating liquids.
Available in iron or steel castings.
Fitted with mechanical seal and relief valve.

Mechanical seal version shown.
Gland packed and sealless versions
also available.

CONSTANT PRESSURE CONTROL PUMPS

C.P.C. is a patented mechanism which automatically alters the eccentricity of the rotors to the shaft to match the flow rate of the pump to that possible in the system to maintain the set pressure. C.P.C. pumps have their inner bodies connected to the control piston via the bridge. The control piston is enclosed in a cylinder. Gas pressure is applied to the top of the control piston and the delivery pressure of the pump is fed to the underside of the control piston.

Operation

Considering the complete system shown right. The pump is running and producing a flow against the system discharge pressure 'E'. The cylinder on top of the pump has been charged with a Gas pressure 'D'. Gas pressure 'D' and discharge pressure 'E' should be equal.

Flow is controlled in this example from the System Valve 'F'. If valve 'F' is partially closed, then discharge pressure 'E' will rise. Any rise in discharge pressure will cause a difference in pressure on either side of the control piston 'B', because the discharge pressure is now higher than the gas pressure. Even a very small differential will create a large force on the underside of the control piston 'B', causing it to move upwards, decreasing the eccentricity of the pumping element and thus reducing the pump flow rate. This reduction in flow rate will lower the discharge pressure until both gas pressure 'D' and discharge pressure 'E' are equal again.

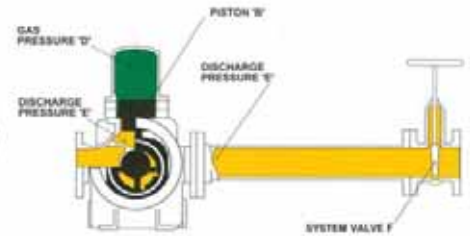

If valve 'F' is completely closed, the control piston moves up and is arranged to stop when the pump reaches its zero flow condition. Conversely if the system valve 'F' is opened, the discharge pressure will fall and the control piston is pushed down by the gas pressure increasing the pump flow rate.

Advantages

- It can be seen that it is a simple matter to electrically interlock several C.P.C. controlled pumps in sequence to produce an extremely flexible system.
- Power consumption is pro-rata with capacity. Consequently with large pumps considerable savings can result.
- Because C.P.C. is extremely sensitive and has a rapid response, the system (flexible hoses etc) is protected against surge pressures.
- Eliminates costly by-passing necessary with fixed capacity pumps and associated return pipework and controllers.
- Particularly in large installations (i.e. ship bunkering) the quantity and quality of labour required is considerably reduced.

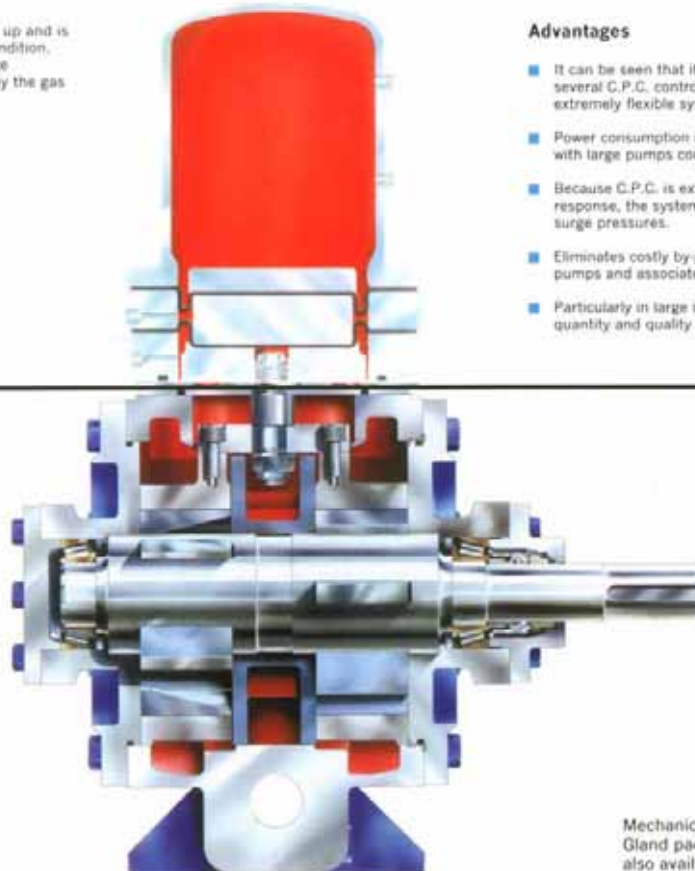

Inboard Pump

Bearings operate in fluid being pumped. Suitable for all lubricating liquids. Available in iron or steel castings. Fitted with mechanical seal and relief valve.

Mechanical seal version shown. Gland packed and sealless versions also available.

REMOTE CONTROL PUMPS

Remote control pumps have their inner bodies connected to an actuator. The actuator can be electro-mechanical, electro-pneumatic, or pneumatic type. Flow control between zero and maximum and reverse between maximum and zero is achieved by the actuator receiving a signal from an external source and moving accordingly. Movement of the actuator changes the position of the inner bodies, altering the eccentricity of the rotors to the shaft, thereby changing the flow rate.

The control signal can be calibrated to flow rate, linked to a pressure transducer to maintain a constant pressure or can match the control pump to process requirements by means of further signals analysed in a signal comparator. Actuators can be fitted with manual over-ride to give the extra advantages of the manual control pumps described above.



Advantages

- Remote control is achieved without the need for costly remote control variable speed gearboxes or flow control valves and spill back systems.
- Zero flow is achieved without stopping the pump.
- Additional limit switches attached to the control spindle can automatically start and stop the pump as the process requires.

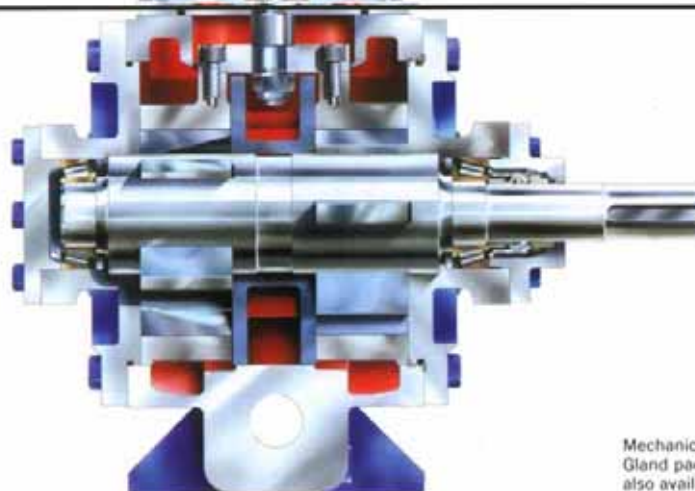

Inboard Pump

Bearings operate in fluid being pumped.
Suitable for all lubricating liquids.
Available in iron or steel castings.
Fitted with mechanical seal and relief valve.

Mechanical seal version shown.
Gland packed and sealless versions
also available.

FIXED CAPACITY PUMPS

Pumps can be supplied in a fixed flow form with the addition of the fixed flow cover. The bridge block is secured to the body centre piece, which in turn locks the inner bodies in the full flow position.

- As the pump is basically the same as the variable flow pump a fixed capacity pump can be installed to begin with and then converted to variable flow at a later date if it is found necessary.

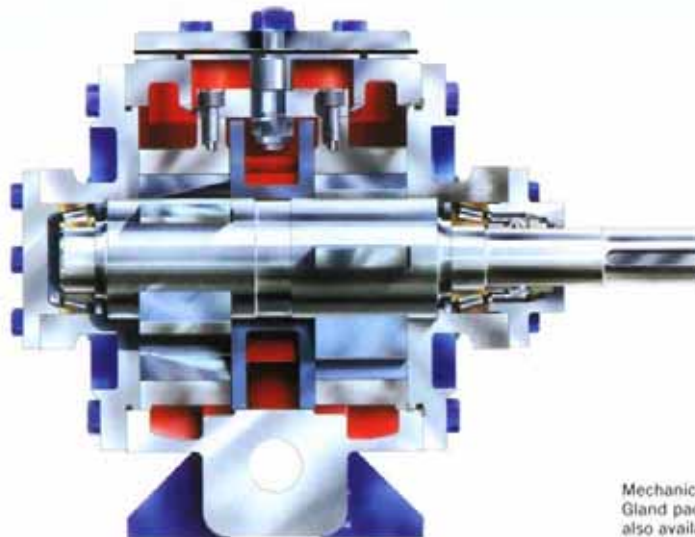

Inboard Pump

Bearings operate in fluid being pumped.
Suitable for all lubricating liquids.
Available in iron or steel castings.
Fitted with mechanical seal and relief valve.

Mechanical seal version shown.
Gland packed and sealless versions
also available.

MANUAL CONTROL PUMPS

Manual control pumps have their inner bodies connected to a hand wheel via the control spindle. Flow control between zero and maximum is achieved by rotating the hand wheel which changes the position of the inner bodies altering the eccentricity of the rotors to the shaft, thereby changing the flow rate. The hand wheel is equipped with an indicator calibrated in % eccentricity to facilitate easy setting within 1% accuracy. Flow can also be reversed and controlled between zero and maximum in the reverse direction.

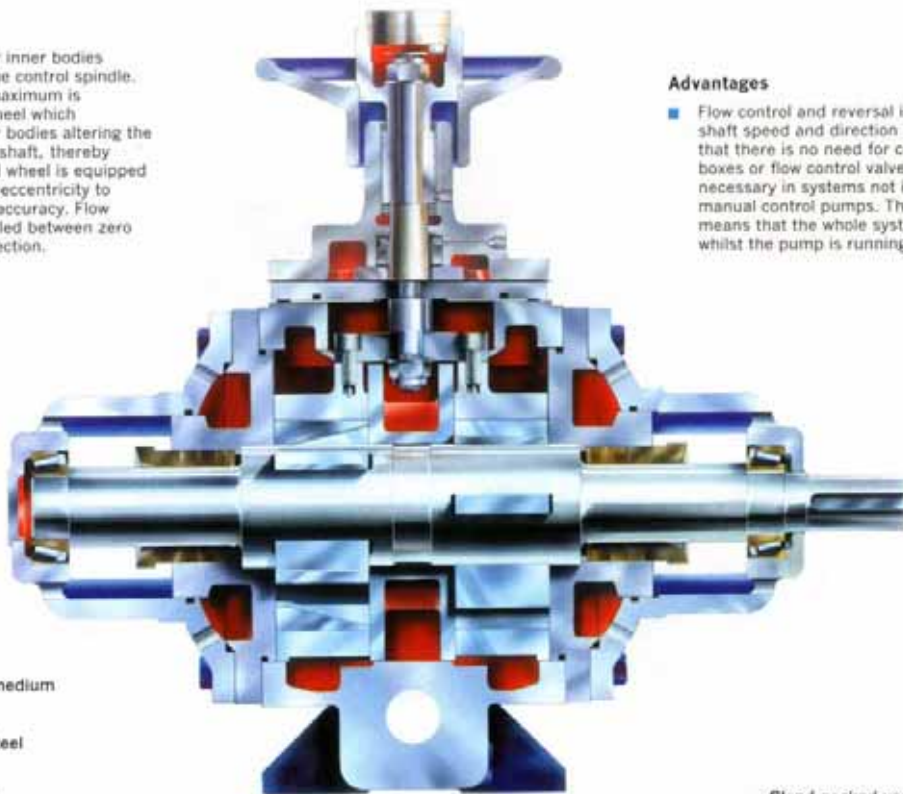

Advantages

- Flow control and reversal is achieved at constant shaft speed and direction of rotation. This means that there is no need for costly variable speed gear boxes or flow control valves that would be necessary in systems not incorporating Plenty manual control pumps. The zero flow position means that the whole system can be interrupted whilst the pump is running.

Outboard Pump

Bearings are separated from the medium being pumped.
Suitable for low lubricity liquids.
Available in iron, steel, stainless steel or bronze castings.
With or without heating jackets.
Gland packed, or mechanical seal.
Fitted with a relief valve.

Gland packed version shown.
Mechanical seal version also available.

CONSTANT PRESSURE CONTROL PUMPS

C.P.C. is a patented mechanism which automatically alters the eccentricity of the rotors to the shaft to match the flow rate of the pump to that possible in the system to maintain the set pressure. C.P.C. pumps have their inner bodies connected to the control piston via the bridge. The control piston is enclosed in a cylinder. Gas pressure is applied to the top of the control piston and the delivery pressure of the pump is fed to the underside of the control piston.

Operation

Considering the complete system shown right. The pump is running and producing a flow against the system discharge pressure 'E'. The cylinder on top of the pump has been charged with a Gas pressure 'D'. Gas pressure 'D' and discharge pressure 'E' should be equal.

Flow is controlled in this example from the System Valve 'F'. If valve 'F' is partially closed, then discharge pressure 'E' will rise. Any rise in discharge pressure will cause a difference in pressure on either side of the control piston 'B', because the discharge pressure is now higher than the gas pressure. Even a very small differential will create a large force on the underside of the control piston 'B', causing it to move upwards, decreasing the eccentricity of the pumping element and thus reducing the pump flow rate. This reduction in flow rate will lower the discharge pressure until both gas pressure 'D' and discharge pressure 'E' are equal again.

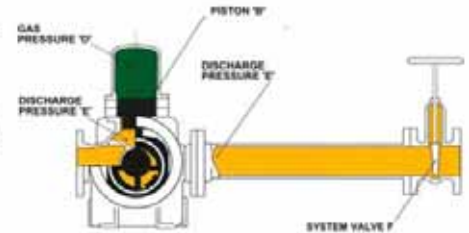

If valve 'F' is completely closed, the control piston moves up and is arranged to stop when the pump reaches its zero flow condition. Conversely if the system valve 'F' is opened, the discharge pressure will fall and the control piston is pushed down by the gas pressure increasing the pump flow rate.

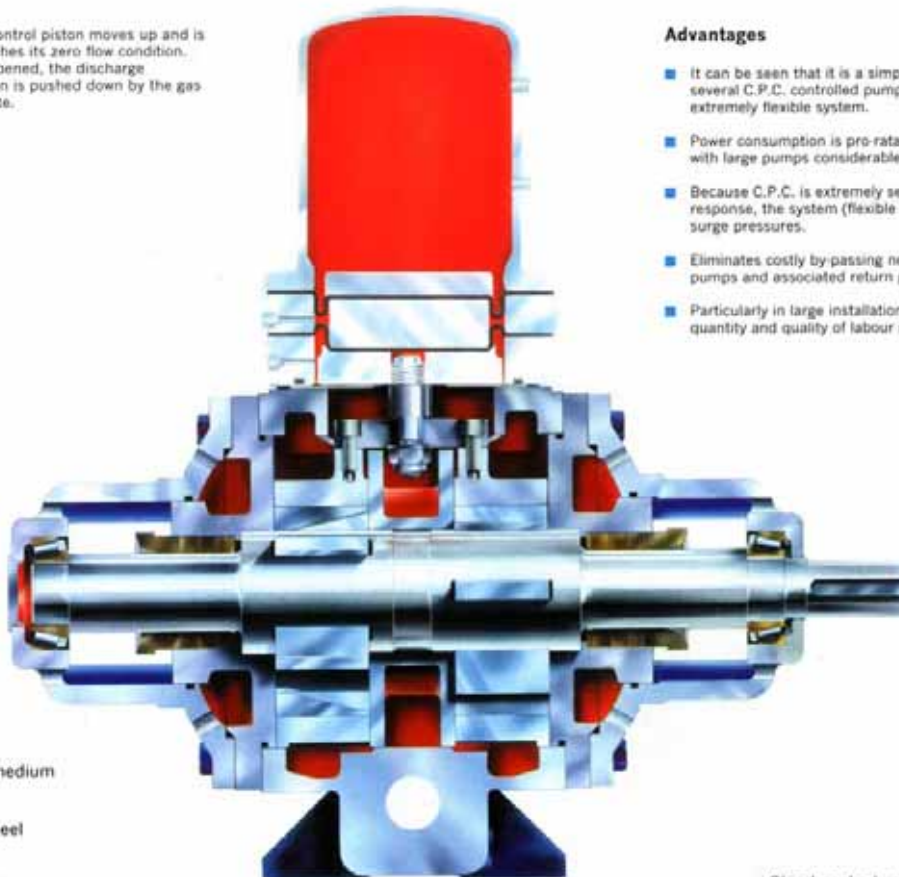

Outboard Pump

Bearings are separated from the medium being pumped.
Suitable for low lubricity liquids.
Available in iron, steel, stainless steel or bronze castings.
With or without heating jackets.
Gland packed, or mechanical seal.
Fitted with a relief valve.

Advantages

- It can be seen that it is a simple matter to electrically interlock several C.P.C. controlled pumps in sequence to produce an extremely flexible system.
- Power consumption is pro-rata with capacity. Consequently with large pumps considerable savings can result.
- Because C.P.C. is extremely sensitive and has a rapid response, the system (flexible hoses etc) is protected against surge pressures.
- Eliminates costly by-passing necessary with fixed capacity pumps and associated return pipework and controllers.
- Particularly in large installations (i.e. ship bunkering) the quantity and quality of labour required is considerably reduced.

Gland packed version show.
Mechanical seal version also available.

REMOTE CONTROL PUMPS

Remote control pumps have their inner bodies connected to an actuator. The actuator can be electro-mechanical, electro-pneumatic, or pneumatic type. Flow control between zero and maximum and reverse between maximum and zero is achieved by the actuator receiving a signal from an external source and moving accordingly. Movement of the actuator changes the position of the inner bodies, altering the eccentricity of the rotors to the shaft, thereby changing the flow rate.

The control signal can be calibrated to flow rate, linked to a pressure transducer to maintain a constant pressure or can match the control pump to process requirements by means of further signals analysed in a signal comparator. Actuators can be fitted with manual over-ride to give the extra advantages of the manual control pumps described above.

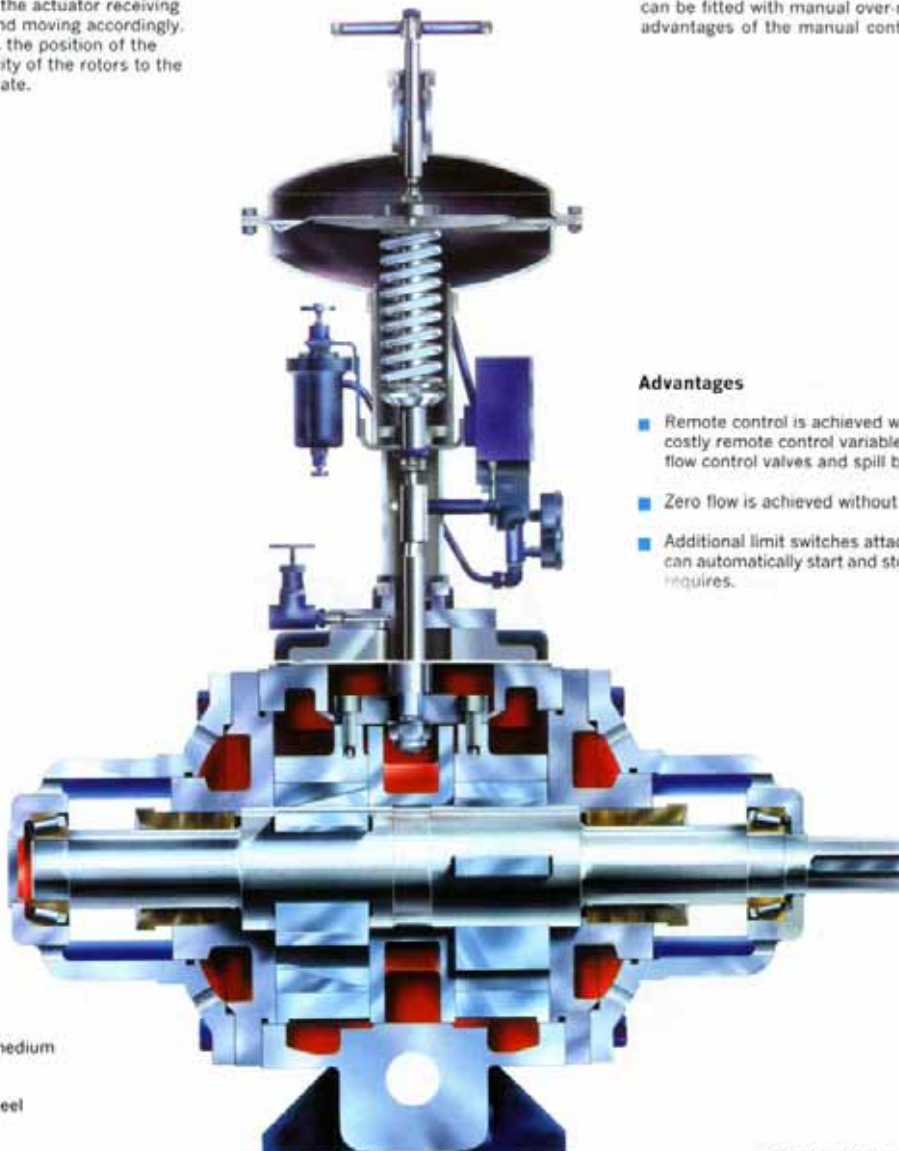

Advantages

- Remote control is achieved without the need for costly remote control variable speed gearboxes or flow control valves and spill back systems.
- Zero flow is achieved without stopping the pump.
- Additional limit switches attached to the control spindle can automatically start and stop the pump as the process requires.

Outboard Pump

Bearings are separated from the medium being pumped.
Suitable for low lubricity liquids.
Available in iron, steel, stainless steel or bronze castings.
With or without heating jackets.
Gland packed, or mechanical seal.
Fitted with a relief valve.

Gland packed version shown.
Mechanical seal version also available.

FIXED CAPACITY PUMPS

Pumps can be supplied in a fixed flow form with the addition of the fixed flow cover. The bridge block is secured to the body centre piece, which in turn locks the inner bodies in the full flow position.

- As the pump is basically the same as the variable flow pump a fixed capacity pump can be installed to begin with and then converted to variable flow at a later date if it is found necessary.

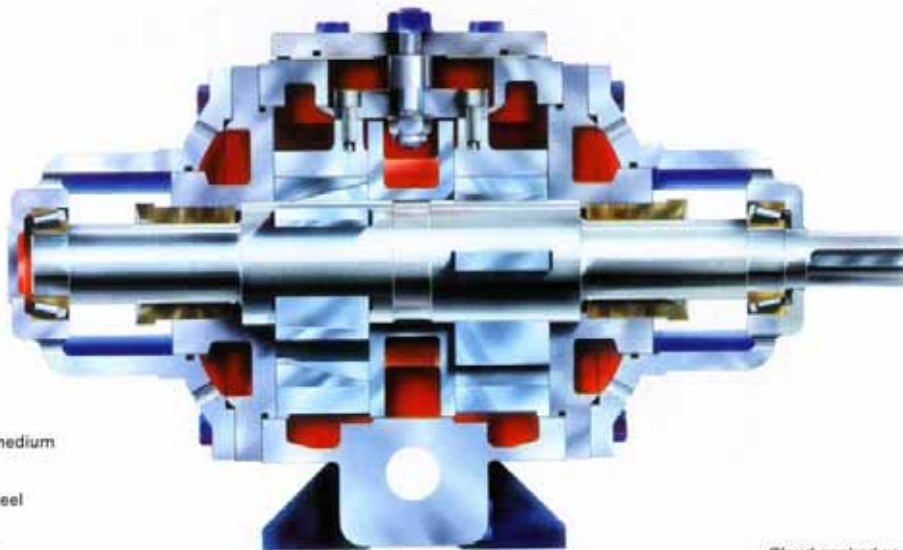

Outboard Pump

Bearings are separated from the medium being pumped.
Suitable for low lubricity liquids.
Available in iron, steel, stainless steel or bronze castings.
With or without heating jackets.
Gland packed, or mechanical seal.
Fitted with a relief valve.

Gland packed version show.
Mechanical seal version also available.

U2000 HEAVY DUTY SLIDING VANE PUMP

U2000

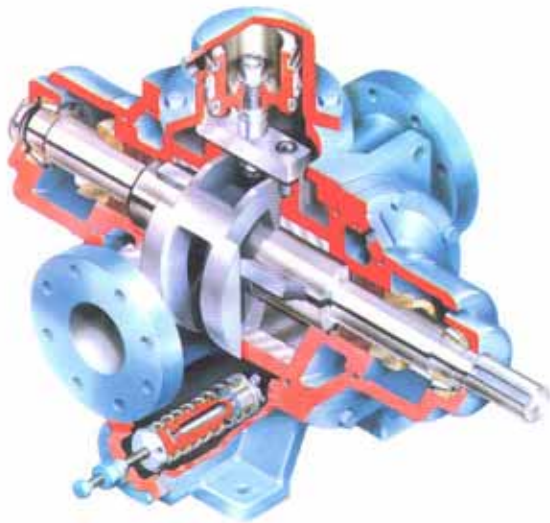

Standard pump assembly options include:

- INTERNAL OR EXTERNAL ROLLER BEARINGS
- INTERNAL SLEEVE BEARINGS
- MECHANICAL SEAL OR GLAND PACKING
- SEAL FLUSH AND/OR QUENCH IF REQUIRED
- SINGLE OR DOUBLE MECHANICAL SEALS, CARTRIDGE SEALS IF SPECIFIED
- CAST AND FABRICATED BASEPLATES, WITH DRIP RIM AND DRAIN FACILITY IF REQUIRED
- INTERNAL PRESSURE RELIEF VALVE (EXCLUDED/BLANKED OFF, FOR API 676 SERVICE)
- JACKETED CASINGS FOR HIGH TEMPERATURE DUTIES
- HARDENED ROTATING ASSEMBLY (NITRIDING) FOR ARDUOUS SERVICES

THE ROTATING ASSEMBLY

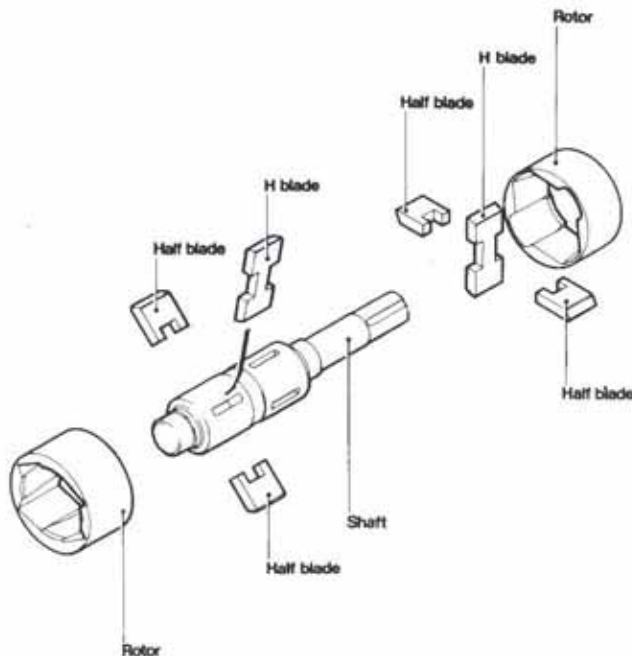

The unique rotating assembly consists of eight working blades made up as two sections set 45° apart, each section consisting of two half blades and one "H" blade.



The photograph shows only one rotor and the roller bearings used on an inboard pump.

VARIABLE FLOW VANE PUMPS

Pump Features

Variable control flow rate from zero to maximum

Fixed speed drive

Comprehensive flow control availability

Plenty vane technology

Versatile design concept

Robust construction

Double Suction

Slow running

Low noise

High volumetric efficiency

Self draining

Viscous pumping

Mechanical seals

Heating jackets

2000 Series parts interchangeability

Relief valve

API 676

& User Benefits

Considerable energy cost savings at reduced flow rates. External pressure and flow control systems not required. Versatile pump utilisation matching pump flow against system demand.

There is no need to use expensive variable speed drives to achieve variable flow, or reverse flow.

Manual, Remote Control and Automatic flow controls are available to suit almost any application.

The Plenty pumping principle has less wear and lower maintenance than conventional vane pump design technology.

Standard pump arrangements suitable for viscosity applications from 30 ssu to 350,000 ssu (for higher viscosities, contact Plenty Ltd).

Heavy duty bearing arrangements designed for long operational periods between routine maintenance.

Low NPSH required characteristics.

In addition to long service life, the slow pumping action has a very low shear rate, dramatically reducing or even eliminating emulsification of the pumped liquid.

Environmentally acceptable for site operators.

Low running costs.

Zero retention, avoids cross contamination when installed for multi product service.

Unlike some other vane pumps, the Plenty vane and blade assembly enables the pump to operate at high viscosities whilst maintaining high efficiency.

The seal housing is in accordance with the standard dimensions of DIN 24960, and can therefore accommodate most brands of mechanical seals.

The pump can be fitted with jacketed covers to allow heating by hot oil or steam. (Electric heat tracing can be used on non jacketed pumps).

U2000 pumps use identical rotors and blades from the G2000 pump range, offering maximum parts interchangeability.

All U2000 pumps can be fitted with an internal pressure relief valve to protect the pump from excess pressures.

Refinery specifications and client special requirements can be accommodated.

U2000

THE PUMPING PRINCIPLE



The eccentricity between the shaft and rotor cause the chambers between the rotor and blades to vary in size as the pump rotates. The liquid entering the pump is guided into the ends of the rotor and then back out through the discharge port.

There are eight pumping sectors and the illustration shows how the sector increases and decreases in size during rotation. Each sector in turn acts in the same manner, causing the continuous pumping action.

Unlike a conventional vane pump the blade tip is not rotating at high peripheral speeds against a liner (which

This pumping principle has a low shear rate which is important for blending lube oils or pumping shear sensitive fluids such as oily water mixtures to a separator for example.

*NOTE. The smallest pump model U2000 - 10 (2") incorporates single suction 4 blade design due to small flow rates and corresponding compact construction.

could cause a rapid wear to the blade tip). The U2000 blades are gently sliding along a flat inside the rotor, thus reducing wear and maintaining high volumetric efficiency.

Variable flow is achieved by changing the eccentricity between the shaft and the rotor. As the eccentricity is decreased the volume of the chambers decreases thus lowering the flow rate. When the shaft and rotor are concentric there is no pumping action, no flow and no hydraulic horsepower absorbed. Reverse flow can also be achieved by increasing the eccentricity over the shaft instead of under the shaft.

VARIABLE FLOW VANE PUMPS

APPROXIMATE DIMENSIONS

PUMP SIZE	10	20	40	100	250	350	500	Standard flanges are to ANSI dimensions S.G. IRON - ANSI 150FF. STEEL - ANSI 150RF and 300RF.
SUCTION	2"	3"	4"	6"	10"	12"	14"	
DISCHARGE	2"	3"	4"	6"	8"	10"	12"	

U2000

TYPICAL OUTBOARD BEARING PUMP.

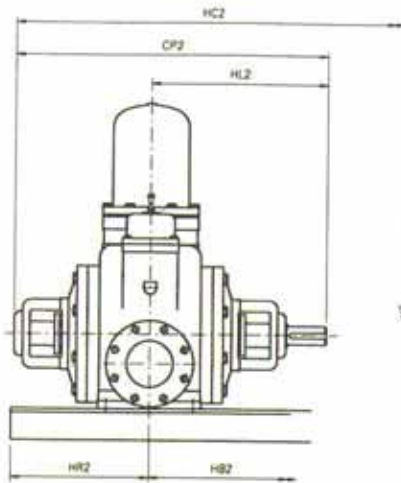

ELECTRIC ACTUATOR CONTROL

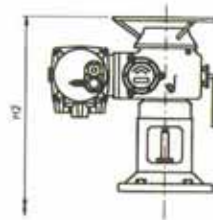

MANUAL CONTROL

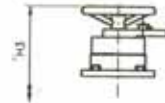

PNEUMATIC ACTUATOR CONTROL

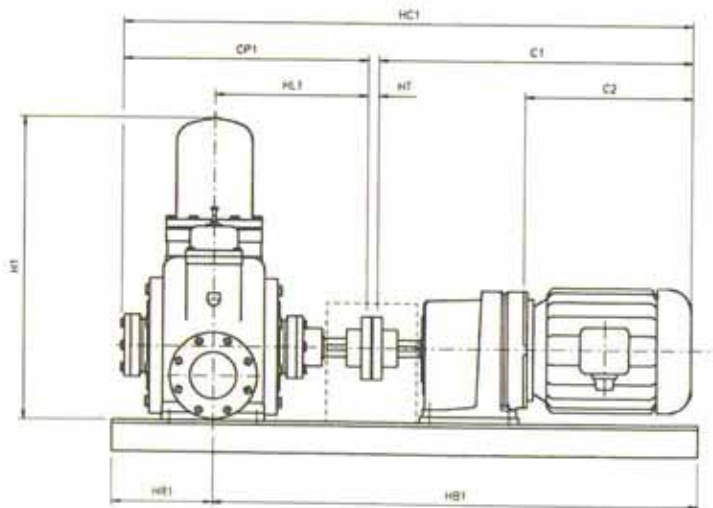
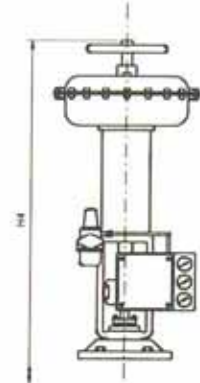

TYPICAL INBOARD BEARING PUMP, COMPLETE WITH GEARED MOTOR AND CONSTANT PRESURE CONTROL (CPC).

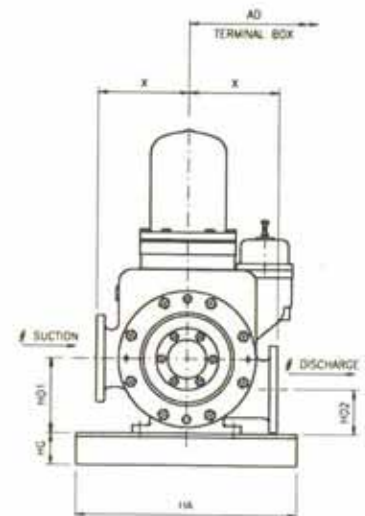

VARIABLE FLOW VANE PUMPS

APPROXIMATE DIMENSIONS ONLY (Inches), DO NOT USE FOR INSTALLATION PURPOSES.

PUMP SIZE	PUMP												UNIT				DRIVER *							
	CP1	CP2	HD1	HD2	H1	H2	H3	H4	HL1	HL2	X	HA	HC	HRT	HR2	HT	FRAME	AD	HB1	HB2	HC1	HC2	C1	C2
10	14.30	16.90	6.50	3.15	16.00	20.85	17.85	32.00	9.05	9.90	53.15	12.00	4.00	4.75	6.50	1.40	145T	9.05	27.00	27.75	33.60	36.20	17.90	11.20
																	215T	11.40	35.05	36.00	41.85	44.45	26.15	16.95
20	17.70	21.60	6.00	4.00	23.25	24.40	21.05	43.65	11.05	12.65	6.70	14.75	4.75	6.10	8.25	1.60	145T	9.05	30.60	32.30	38.65	42.50	19.40	10.15
																	256T	12.45	45.10	46.65	53.20	57.05	33.90	22.00
40	22.80	28.35	7.85	4.75	28.60	32.50	26.50	44.70	14.15	16.10	8.95	19.30	5.10	8.00	11.60	2.00	182T	9.50	37.00	39.00	47.10	52.65	22.36	13.15
																	324T	14.55	59.85	61.80	69.90	75.50	45.20	29.50
100	30.95	39.40	9.45	5.70	40.10	43.60	33.45	70.00	19.30	22.40	11.50	24.40	6.00	11.00	16.15	2.25	213T	11.40	50.00	53.15	62.90	71.40	29.60	16.95
																	365T	19.50	73.60	76.95	86.75	95.20	53.40	30.20
250	40.00	48.85	18.10	18.10	58.45	56.25	49.20	92.50	25.75	27.90	15.00	30.70	6.00	13.60	20.00	3.00	250T	12.45	65.00	67.30	80.70	89.50	37.70	22.00
																	449T	21.45	83.45	85.80	99.10	107.90	56.10	42.65

CONSULT PLENTY FOR DIMENSION INFORMATION.

* Driver dimensions listed are for the smallest and largest motor sizes for each pump. Larger size pumps can be supplied with separate gearbox and motor as required.
 ** Iron pumps are supplied with standard "Self Draining" flanges, as shown. Steel pumps are supplied with "In-Line" non "Self Draining" flanges.
 # Pumps can be constructed with suction left as shown or suction right, to suit customer requirements.

FLOW RANGE

(Pump frame size is nominal design flow in M³/Hr. e.g. G2000-40 is nominally a 40M³/Hr Pump).

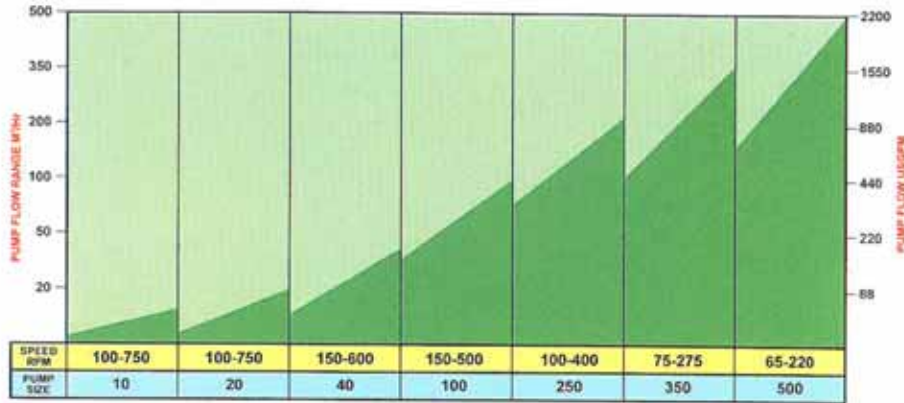

CONTROL APPLICATIONS

The process diagrams below show systems which could relate to any industry.

MANUAL CONTROL

Diagram 1.

This represents a system where it may be necessary to pump into a process under varying conditions.

- Bitumen Plant residue blowing tower where flow varies with production demand.
- Grease Plant where off take from process kettles may be variable.

Diagram 2.

This represents a blending system where the flow of two or more different liquids must be controlled to produce different end products.

- Fuel oil blending at a bunkering terminal.
- Lube oil blending.
- Bitumen blending.
- Molasses / water.

Reverse Flow

The reverse flow feature of Manual Control Pumps means that the same pump can be used for pumping in both directions.

- Loading & unloading from road or rail tankers.
- Filling & emptying of day storage tanks.
- Line stripping back to tank.

CONSTANT PRESSURE CONTROL

CPC is a flow control system where the pump can exactly match flow demand in the system automatically, whilst maintaining a constant discharge pressure.

Diagram 1.

This represents three different systems where product is drawn from storage and pumped to either filling machines, a tanker loading system or the suction of another pump. The factor that links each application is that each system has a varying or intermittent flow demand (i.e. discharge valve opening and closing against pump).

- Lube oil blender feed pumps where flow is variable and intermittent.
- Can/Drum filling where flow is on-off.
- Road/Rail loading systems where flow is variable and intermittent.
- Ships bunkering where flow is variable but system pressure must not be exceeded.
- Boiler fuel feed where demand is variable.

The use of a pump with CPC control in all cases eliminates the need for control valves & spillback lines.

REMOTE CONTROL

Diagram 1.

This represents a system where the flow to a process is controlled via feedback from the process itself.

- Blending systems where pump can be continually adjusted to maintain the optimum blend.
- Any process where production demand is variable and feedstock rates must be adjusted accordingly.
- Flow control from discharge pressure transducer to ensure max. system pressure is not exceeded.
- Flow control from suction pressure transducer to eliminate cavitation (i.e. cold starts or variable viscosity conditions).
- Flow control from suction pressure transducer to match flows from downstream pumps (i.e. ship unloading where ships pumps can be different sizes).

Remote control pumps may also be used in place of manual control pumps where the pump may be in a remote location and flow rates are to be controlled from a central control room.

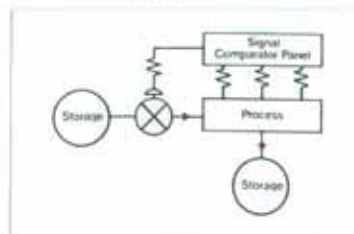
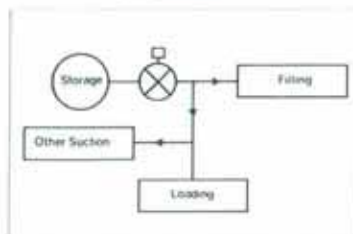
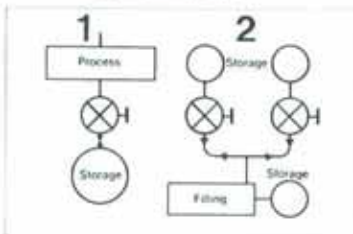
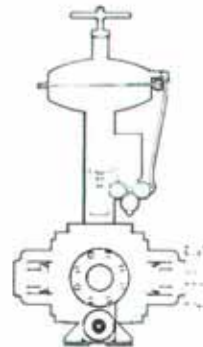
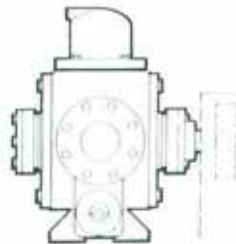
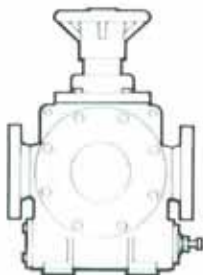

U2000

VARIABLE FLOW VANE PUMPS

Europe

SPX Process Equipment
Plenty Mirrlees Pumps
Earl Haig Road
Hillington
Glasgow, G52 4JN
Tel : +44 (0)141 883 0314
Fax : +44 (0)141 882 2752
E-mail: pumps.plenty@processequipment.spx.com
Web site: www.spxprocessequipment.com

Americas

SPX Process Equipment
611 Sugar Creek Road
Delavan, WI 53115 U.S.A.
Phone : 1-800-252-5200 or 262-728-1900
Fax : 1-800-252-5012 or 262-728-4904
E-mail: info@processequipment.spx.com
Web site: www.spxprocessequipment.com

Asia

Hock Teoh Aun
SPX Process Equipment
27 International Business Park #04-02
Primefield-Landmark Building, Singapore 609924
Tel : +65-6264 4366
Fax : +65-6265 9133
E-mail: teoh.hock.aun@processequipment.spx.com
Web site: www.spxprocessequipment.com

Middle East

Maher Soubra - Regional Manager
SPX Process Equipment
Bran+Luebbe, Lightnin, Plenty
P.O. Box 2234
Dubai, UAE
Tel. +971 4 3438322
Fax: +971 4 3438399
Mobile: +971 50 6442189
E-mail: maher.soubra@processequipment.spx.com
Web site: www.spxprocessequipment.com