

# Plenty



**MAGMO**

**Magmo Masseurite Pump**

# Plenty Mirrlees

## MAGMO MASSECUIE PUMP

The Magmo pump is a positive displacement pump which uses the 'ellipse and scraper' pumping principle. The basic design was originally conceived by the Sugar Industry itself, and Plenty Mirrlees Pumps have been manufacturing this type of pump for over 30 years.

Magmo pumps are designed principally to handle high viscosity abrasive sugar products that contain sugar crystals, such as Masecuite, Magma and Molasses. The design ensures that the Sugar crystals contained within the liquids are not damaged by the pumping action, and that the pump is subjected to minimum wear.

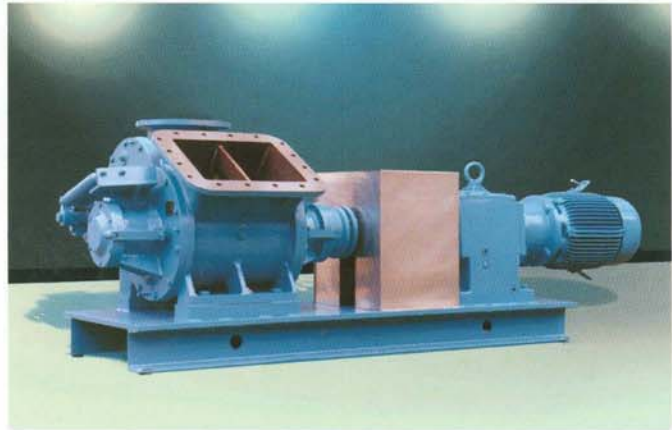

*Magmo No. 10 unitised with a Gearmotor and Shear-pin Coupling*

Magmo pumps are available in three sizes, No. 6, No. 8 and No. 10. The pump size indicates the discharge flange bore in inches.

## PRINCIPLE OF OPERATION

The pumping principle is very simple. An elliptical shaped rotor rotates in a cylindrical housing. The pumped medium is trapped in the cavities formed between the rotor and the housing, and is carried round from suction to discharge. A hinged sealing arm, which follows the surface of the rotor, scrapes off the pumped medium and directs it up into the discharge. The sealing arm is spring loaded to maintain contact with the rotor, however, above 2 bar g it is assisted by the discharge pressure, so the spring force is unnecessary.

Special care has been taken in designing the suction branch to ease the flow into the pump. This avoids starvation, and allows the pump to run at higher speeds.

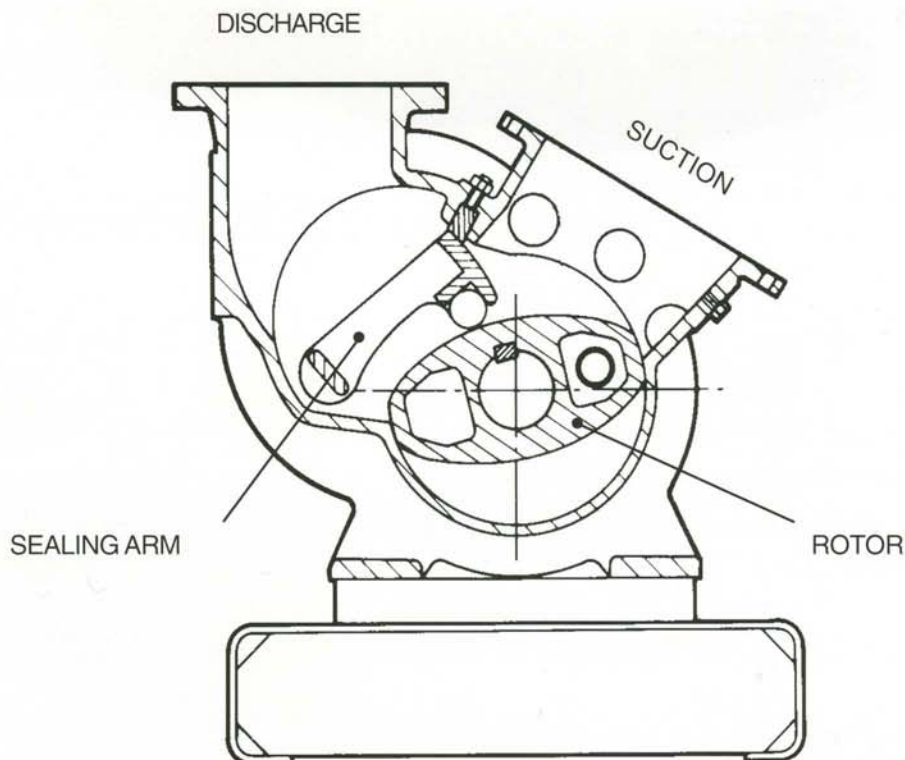



## BEARING & SEALING ARRANGEMENT

The bearing and sealing arrangement has been designed to deal with the wear and leakage problems associated with high viscosity abrasive duties. The bearing bushes are divided into an inner and outer section. The inner section divides the liquid in the pump and the grease in the bearing. The outer portion, which has longitudinal grooves, forms the bearing.

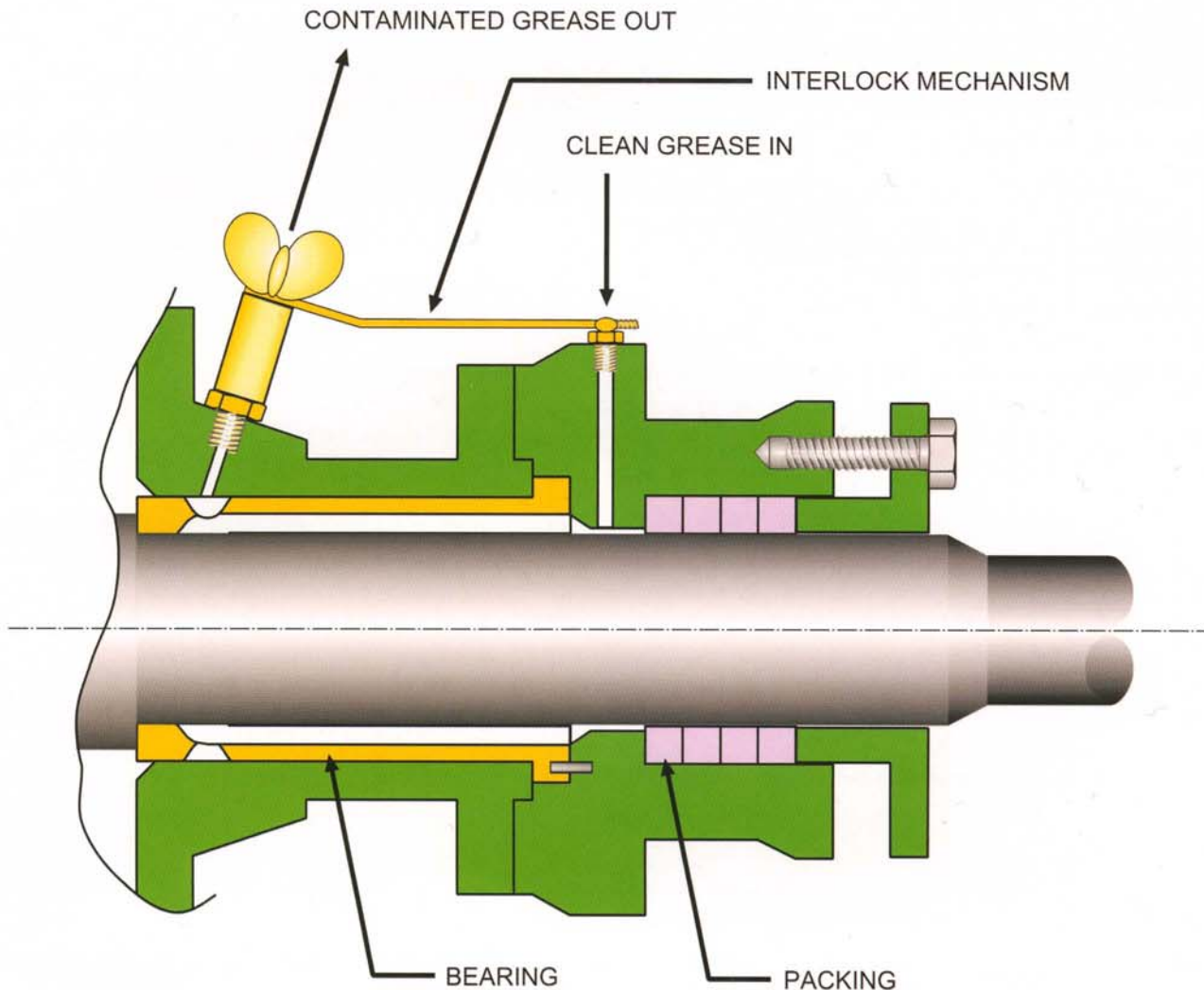

The grease in the bearing will slowly become contaminated over time by the pumped medium. This contaminated grease must be replaced by fresh grease to avoid premature bearing wear.

Re-greasing the bearing is a flushing operation. Fresh grease is introduced through a grease nipple at the outer end of the bearing, displacing the old contaminated grease along the grooves and through a drain valve at the inner end. The drain valve is simply interlocked to the grease nipple to ensure that both are open during greasing. This prevents grease being forced into the main pumping chamber and contaminating the pumped liquid.

This configuration of bearing ensures minimum contamination of the bearing, and that the packing is sealing clean grease and not abrasive liquid.

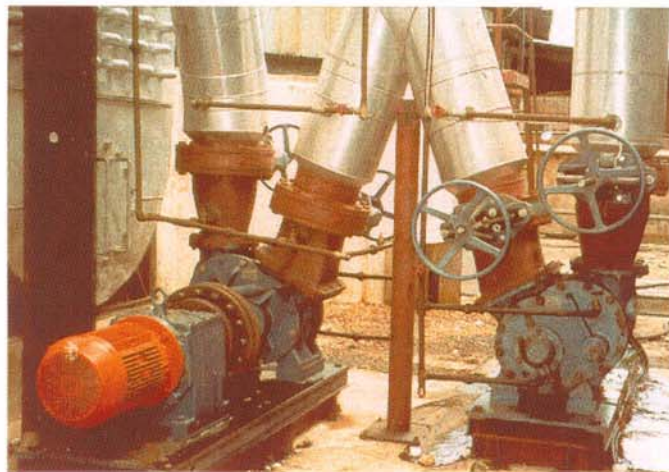

*Magmo pumps recirculating Maseccuite to a Vertical Crystallizer*

# PERFORMANCE TABLE

 A or B Masecuite.

 C Masecuite.

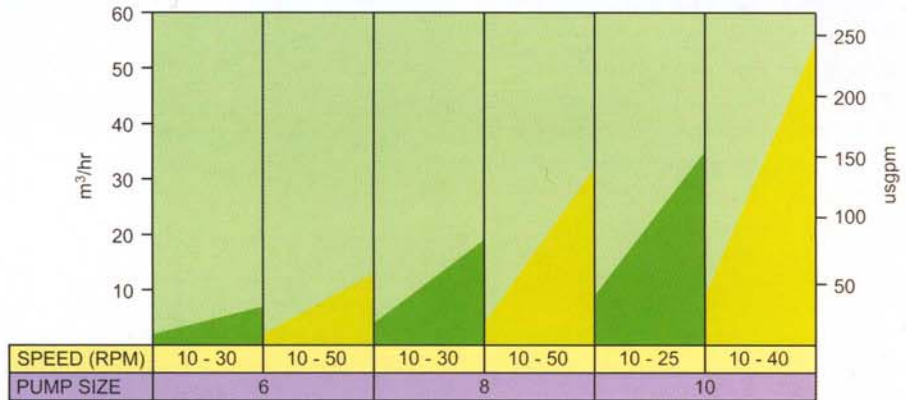

The table above is based upon performance when pumping A, B or C Masecuite. Due to the higher viscosity encountered when pumping C Masecuite, the maximum operating speed of the Magmo pump range is de-rated.

# APPROXIMATE DIMENSIONS

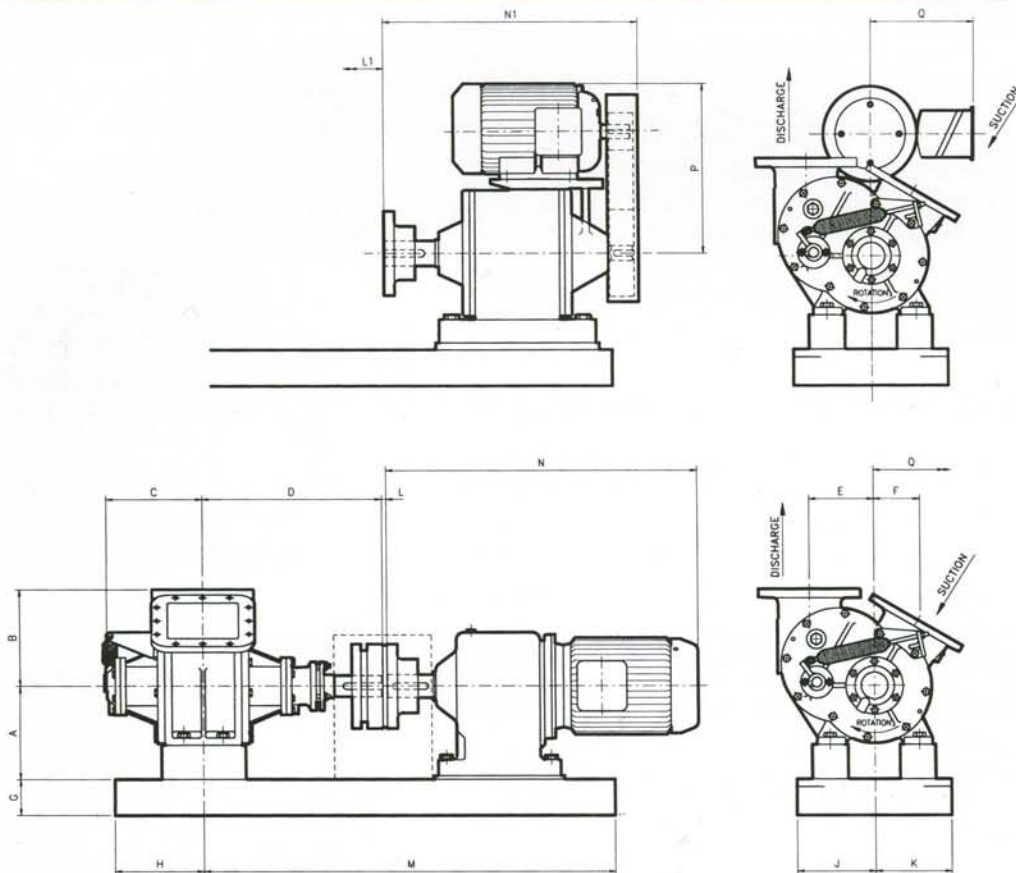

\*Pumps can be constructed with suction right (as shown) or suction left, to suit installation.

Approximate dimensions (mm). DO NOT use for installation purposes.

PUMP SIZE	PUMP ONLY						UNIT						FLANGES		*GEARBOX/MOTOR				
	*A	B	C	D	E	F	G	H	J	K	L	L1	SUCTION	DISCHARGE	M	N	N1	P	Q
6	250	271	270	500	180	122	102	250	216	216	12	12	6"	200 X 200	1150	860	611	441	196
	1300														1006	761	488	196	
8	250	356	367	724	254	159	160	346	300	300	12	12	8"	290 X 290	1150	860	611	441	196
	1300														1157	761	547	250	
10	315	460	527	868	285	201	200	406	457	305	12	12	10"	330 X 450	1300	1006	761	488	196
	390														1800	1397	852	643	341

\*Dimensions are given for the smallest and largest motor and gearbox sizes for each pump.



## PUMP FEATURE

## USER BENEFIT

**Gentle pumping action**

Minimum sugar crystal damage.

**Large suction port**

Eliminates cavitation problems, and allows higher running speeds.

**Good tolerance to large particles**

Prevents pump seizure

**Grease packed bearings with flushing arrangement**

Extended bearing and pump life.  
Zero leakage of pumped liquid.

**Replaceable sealing strip and sealing arm wear strip**

Low cost wearing parts that are easily replaced to extend the overall pump life through a number of campaigns.

**Heavy duty sealing arm spring**

Ensures operation through many millions of cycles.

**Shear pin coupling**

Dis-engages drive if an obstruction enters the pump, or the discharge pressure exceeds 15 bar g, ensuring there is no damage to the pump drive train.

**Belt Drive Unit**

Belts will slip if an obstruction enters the pump, or the discharge pressure exceeds 15 barg, ensuring there is no damage to the pump drive train.  
Pump speed can be easily changed on site by changing the pulley diameters.

# MAGMO

## OPERATING PARAMETERS

Magmo pumps are designed to operate primarily on Masecuite, Magma and Molasses.

Flow range	-	1.2 m <sup>3</sup> /hr to 56 m <sup>3</sup> /hr
Speed	-	10 rpm to 50 rpm
Discharge Pressure	-	7.0 bar g
Viscosity	-	Unlimited



Bareshaft Magmo No. 10

## MATERIALS OF CONSTRUCTION

### STANDARD CONSTRUCTION

Casing	-	Cast Iron
Rotor	-	Cast Iron
Sealing Arm	-	Ductile Iron (with Hardened edge)
Shaft	-	Ductile Iron
Bearing Bushes	-	Bronze
Sealing	-	Mechanical Seal

### OPTIONS

Shaft	-	Stainless Steel
Rotor	-	Bronze
Sealing	-	Mechanical Seal
Drive Options	-	Direct Drive from geared motor through a shear-pin coupling. Direct Drive from belt driven gearbox through a standard coupling.

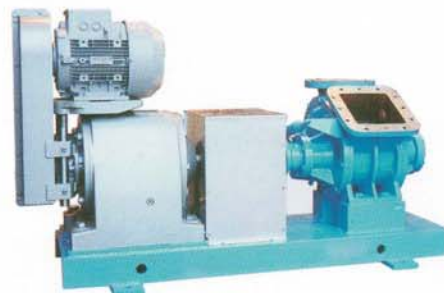

Magmo No. 6 belt driven unit

All Magmo pumps are supplied with steaming out connections as standard.

## Europe and Headquarters

SPX Process Equipment  
Plenty Mirrlees Pumps  
Earl Haig Road  
Hillington  
Glasgow G52 4JN  
Tel: +44 (0) 141 883 0314  
Fax: +44 (0)141 882 2752

For all Triro, Vane, Twinro or  
Magmo requirements, and  
subcontact machining

[pumps.plenty@processequipment.spx.com](mailto:pumps.plenty@processequipment.spx.com)

---

## America's

Margaret M. Docherty  
SPX Process Equipment, Plenty/Lightnin Operation  
135 Mt Boulevard, Rochester, NY 14611  
Tel: 585 527 1283  
Fax: 585 527 1741

[Margaret.Docherty@lightnin.spx.com](mailto:Margaret.Docherty@lightnin.spx.com)

---

## Asia

Hock Teoh  
SPX Process Equipment  
27 International Business Park #04-02  
Primefield Landmark Building, Singapore 609924  
Tel: +65-6264 4366  
Fax: +65-6265 9133

[teoh.hock.aun@processequipment.spx.com](mailto:teoh.hock.aun@processequipment.spx.com)