



2MS75MDSS
Shown

Features

- Achieves over 300 feet of head
- Leak-proof, magnetic drive
- Eliminates seals to reduce friction wear
- High temperature capacity
- Threaded pump connections

Applications

- Toxic or Explosive Fluids
- Aggressive Chemicals
- Biodiesel Production
- Water Treatment
- Galvanic Processes, Surface Treatments
- Scrubber Applications
- Pharmaceutical Industry
- Vapor Degreasers

Cross Section - Magnets

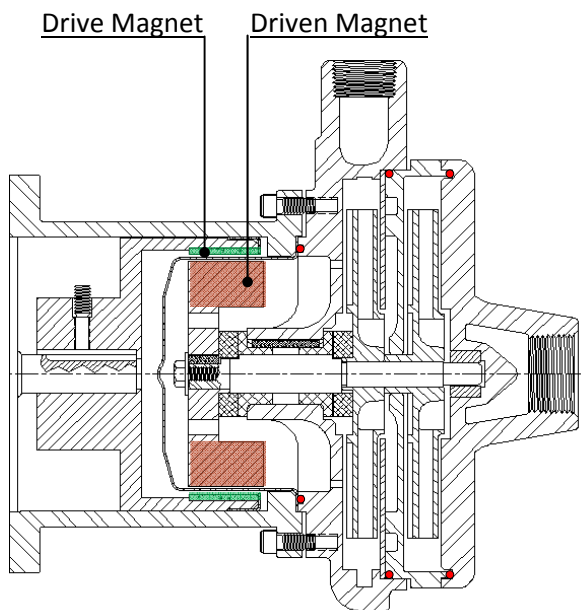

2MS75

Pump Model

2MS75MDSS – 316 Stainless Steel

Standard Specifications

- 2MS75MD Discharge 3/4" FNPT, Suction 1" FNPT
- Maximum Impeller Diameter: 5.98"
- Impeller Material: 316SS
- Motor: NEMA C Face
- O-rings: Viton
- Bushings: Carbon Graphite
- Thrust Washers: Ceramic
- Magnets: Samarium Cobalt

Note: Contact factory for additional options

Performance Curve – 60 Hz

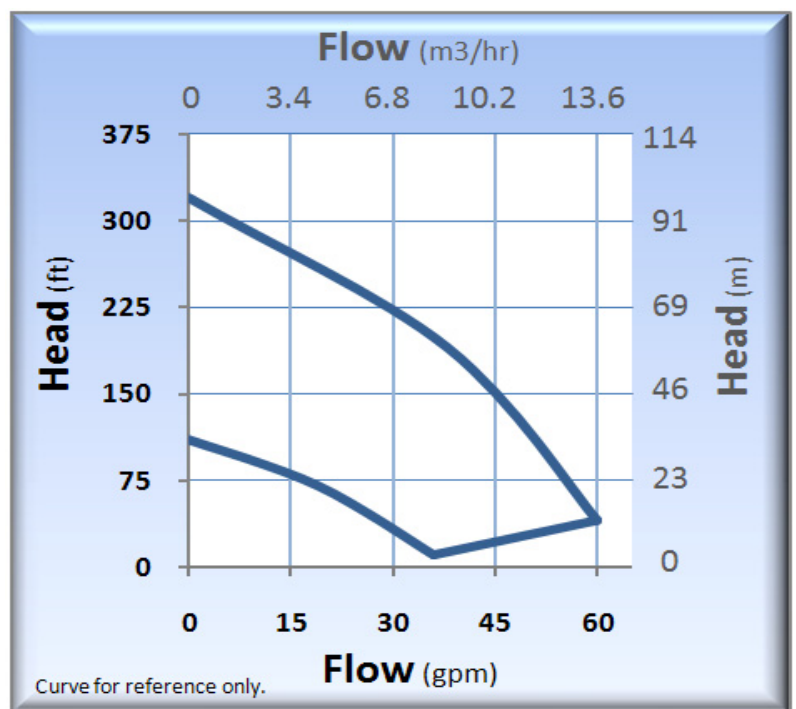

2MS75 (MAG DRIVE)

Technical Information	
Max Flow	60 GPM (14 m3/hr)
Max Head	320 feet (98 m)
Min. Flow	2 GPM (0.5 m3/hr)
Max Working Pressure	300 PSI (21 bar)
Max Temp.	350°F (177°C)*

* Temperature limits will vary depending on O-ring material and type of liquid being pumped.

Materials of Construction	
2MS75MD	SS
Volute	316 Stainless Steel
Impeller	316 Stainless Steel
Bracket	316 Stainless Steel
Fasteners	316 Stainless Steel
O-ring	Viton (STD), Teflon, Buna, EPR, Neoprene, Kalrez, & Fluoro-Silicon
Shaft	316 Stainless Steel (STD), Tungsten Carbide Coated
Bushings	Carbon (STD), Silicon Carbide
Thrust Washers	Ceramic (STD), Silicon Carbide
Magnet Cup	316 Stainless Steel
Magnets	Samarium Cobalt

Dimensions (2MS75 Mag-Drive)

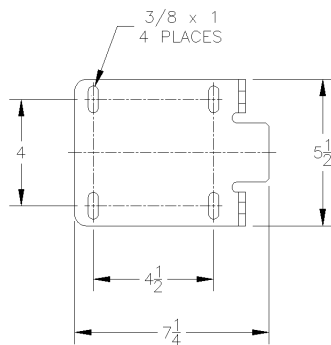
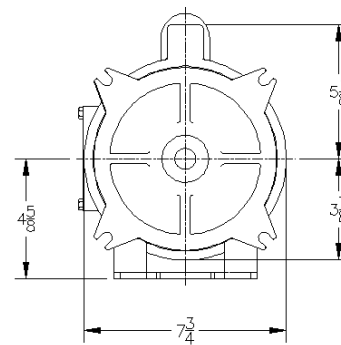
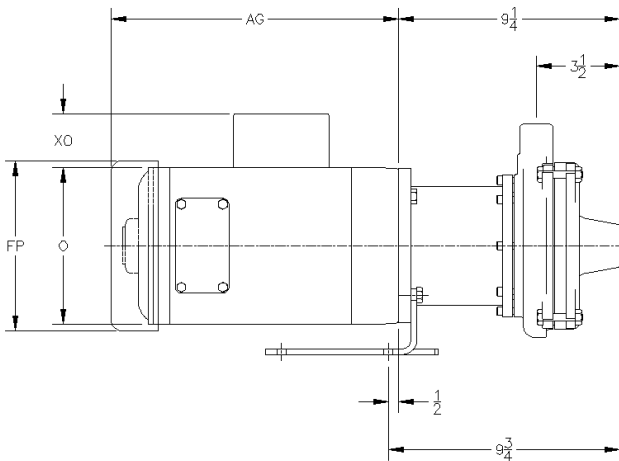

NOTE:
MOTOR DIMENSIONS WILL VARY BY MODEL AND MAKE,
DIMENSIONS ARE TO BE USED FOR REFERENCE ONLY.

HP	RPM	FRM	MOTOR END DIMENSIONS			
			AG	FP	O	XO
1/4	1800	56C	7 3/4	6 1/8	5 3/8	2 1/16
1/3	1800	56C	8 1/4	6 1/8	5 3/8	2 1/16
1/2	1800	56C	8 3/4	6 1/8	5 3/8	2 1/16
3/4	1800	56C	9 1/4	6 1/4	5 3/8	2 1/16
1	1800	56C	10	6 1/4	5 3/8	2 1/16
2	3600	56C	11 1/8	7 3/16	6 7/8	2 1/4
3	3600	56C	12 3/8	7 3/16	6 7/8	2 1/4
5	3600	184C	13 5/8	8 1/2	7 7/8	2 1/4
7-1/2	3600	184C	15 1/8	8 1/2	7 7/8	2 1/4

Note:
Motors 5 HP and above require VFD or soft starter.



21775 Eighth Street East
Sonoma, CA 95476-0329
MAIN (707) 938-8441
TOLL FREE (800) 345-7867
FAX (707) 938-0764
E-mail: sales@pricepump.com
Website: www.pricepump.com

Contact factory for special pump configurations,
same day, and next day delivery options.



Rev. Date: May 2009