



HP75CN  
Shown

## HP75 (End Bell Gasket Design)

### Pump Volute / Impeller Materials

- HP75 (BN) – Bronze / CPVC
- HP75 (BS) – Bronze / 316SS
- HP75 (KN) – Kanigen Plated / CPVC
- HP75 (KS) – Kanigen Plated / 316SS
- HP75 (CN) – CPVC / CPVC
- HP75 (CS) – CPVC / 316SS

### Features

- **End Bell Gasket Design** – Isolates cast iron motor bracket from liquid flow
- **Configuration** – Compact, close coupled design
- **Motor shaft** – Threaded

### Applications

- Chillers / Liquid Cooling
- Chemical Processing
- Booster Pumps
- Water Purification
- Circulation / Filtration
- Air Conditioning / Heat Recovery

### Optional Configurations

- **Power Frame Mounting:**

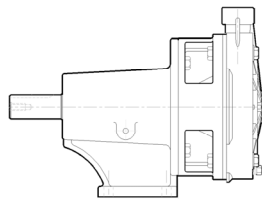

- **Long-Coupled Mounting:**

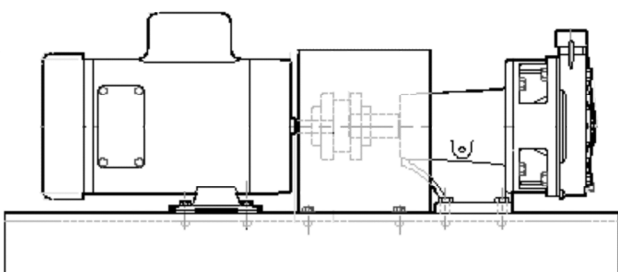

### Standard Specifications

- Discharge 3/4" FNPT, Suction 3/4" FNPT
- Maximum Impeller Diameter: 6.00"
- Motor: NEMA 56J Footless (Multiple enclosures available)
- Mechanical Seal:

Single, 5/8" Type 6 Buna, Carbon vs. Ceramic

*Note: Additional seal options available*

- Bracket Material: Cast Iron (Bronze optional)
- Bell Gasket Material: EPR (Viton optional)

### Performance Curve – 60 Hz

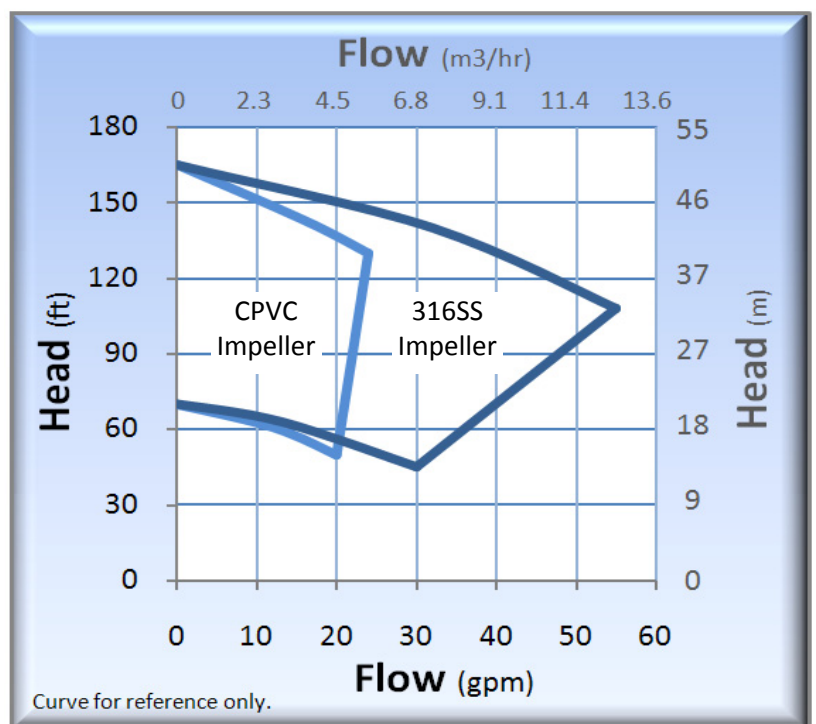

# HP75 (Gasket Design)

Technical Information	
Max Flow (CPVC Impeller)	20 GPM (4.5 m3/hr)
Max Flow (316SS Impeller)	55 GPM (12.5 m3/hr)
Max Head	165 feet (50 m)
Min. Flow	0.5 GPM (0.12 m3/hr)
Max Solid Size	0.030" (0.76 mm)
Max (Type 6 Seal)	75 PSI (5.2 bar)
Working (Type 2106 Seal)	150 PSI (10.3 bar)
Pressure (Type 21 Seal)	150 PSI (10.3 bar)
Max Temp. (CN, KN, BN, CS)	140°F (60°C)*
Max Temp. (KS, BS)	300°F (149°C)*

Materials of Construction						
HP75	BN	BS	KN <sup>+</sup>	KS <sup>+</sup>	CN	CS
Volute	Bronze	Bronze	Kanigen	Kanigen	CPVC	CPVC
Impeller	CPVC	316SS	CPVC	316SS	CPVC	316SS
Bracket	Cast Iron (Bronze Optional)					
Fasteners	18-8 Stainless Steel					
Gasket	EPR (Viton Optional)					

\* Kanigen is an Electroless nickel plating

\* Temperature limits are based on standard seal and gasket materials, and will vary according to the liquid being pumped.

## Dimensions (HP75CN)

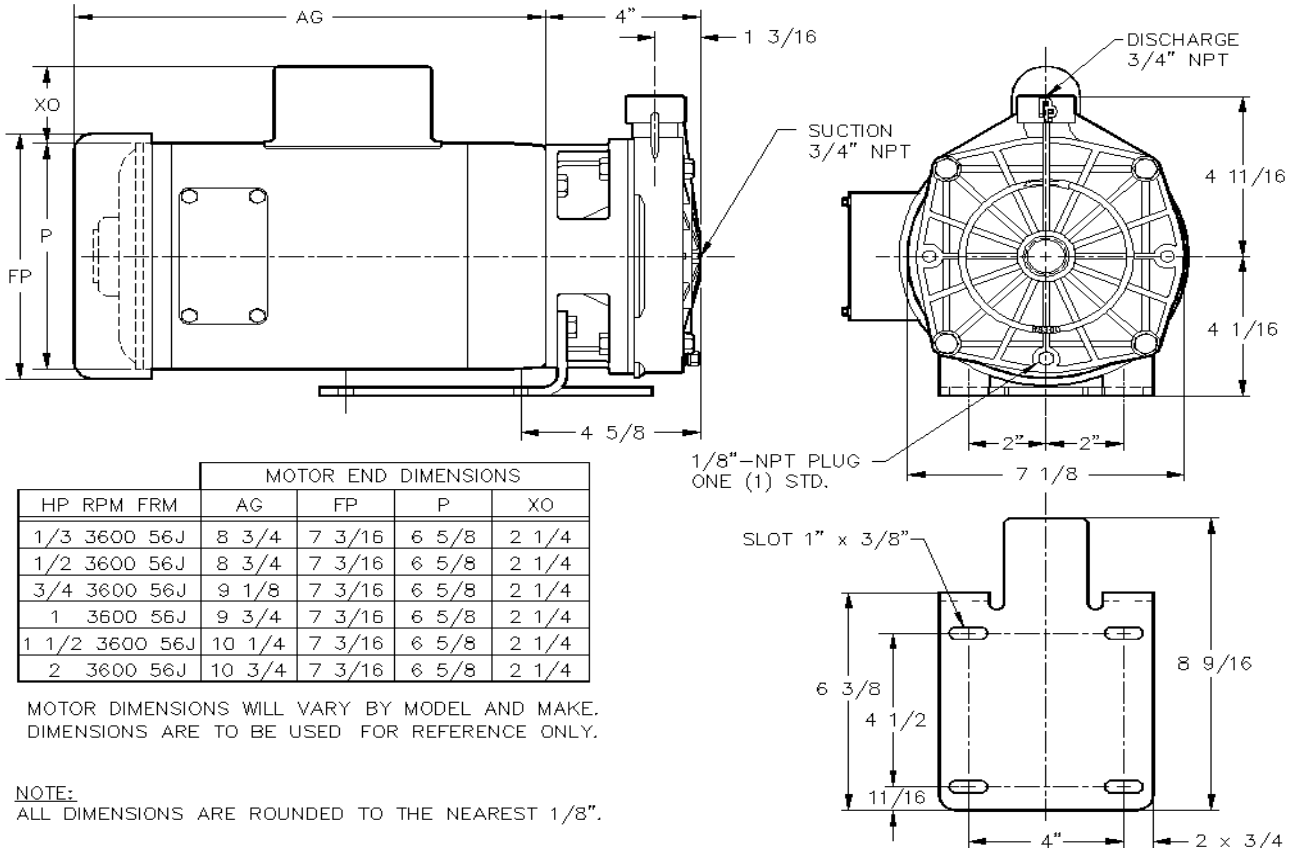

**PRICE PUMP CO.**

Contact factory for special pump configurations, same day, and next day delivery options.

21775 Eighth Street East  
Sonoma, CA 95476-0329  
MAIN (707) 938-8441  
TOLL FREE (800) 345-7867  
FAX (707) 938-0764  
E-mail: [sales@pricepump.com](mailto:sales@pricepump.com)  
Website: [www.pricepump.com](http://www.pricepump.com)

Member of:  
**Hydraulic INSTITUTE**



Rev. Date: May 2009