

Diaphragm pump

DP3

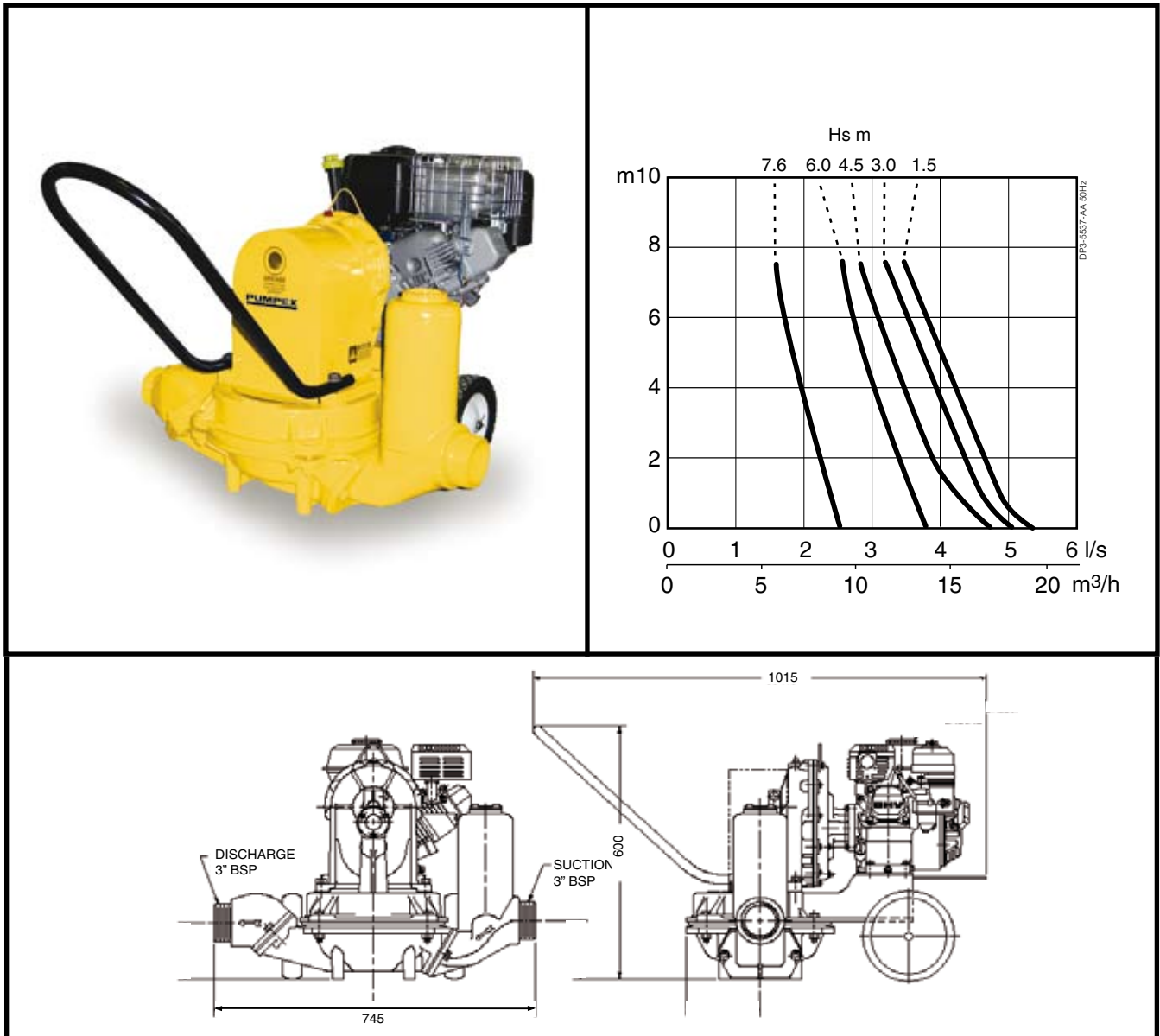

DP3-02.0706.Eng/Digital
The manufacturer reserves the right to alter performance, specifications or design without notice.

Applications

Seepage Dewatering
Sandy- Muddy- Mucky- Water
High Suction Lift
Cleaning Septic Tanks
Pumping Industrial Waste
Pumping Marine Tanks

Features

Aluminum wetted ends
Large opening Flap Valves
Fast, Sure Self Priming (Dry Primes to 7.6 m Suction Lift)
Self Cleaning Water Flow
Enclosed Gears in Oil Bath
Diaphragm and Valves in Neoprene rubber

Technical datas

Suction & Discharge:	G 3" thread
Max. Suction Lift:	7.6 m
Max Discharge Head:	7.6 m
Power:	Honda GX120 3 kW (4 Hp), 3600 rpm
Fuel Tank Capacity:	2.5 l
Continuous Run Time/Tank):	3 Hr
Starting Method:	Recoil
Free passage:	44 mm
Weight:	59 kg

