

Submersible sludge pump

SP 20

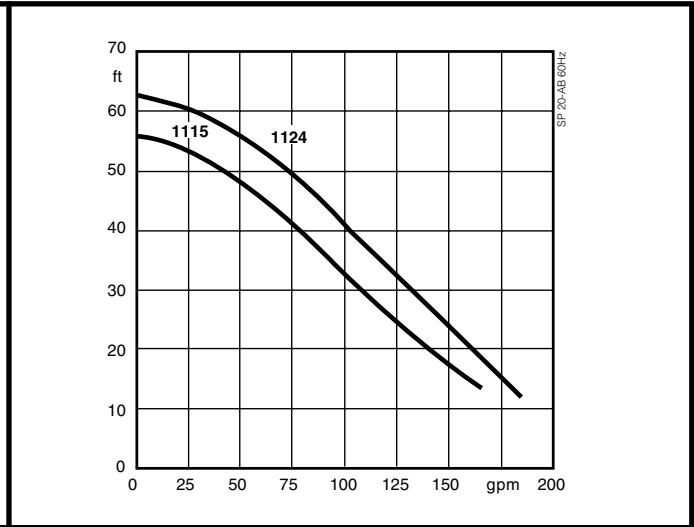
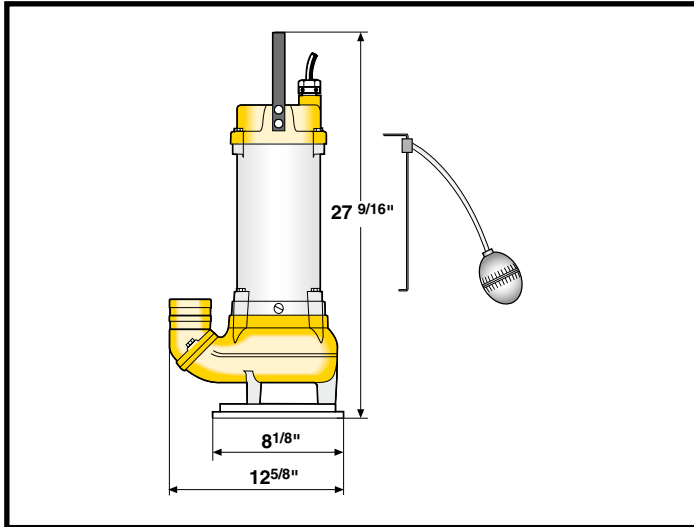

SP20.02.0906.US 60 Hz
The manufacturer reserves the right to alter performance, specifications or design without notice.

Specification

Electric submersible pump.
Maximum submergence: 65 ft. Protection class IP 68.
Max temperature of pumped medium at max power input and continuous duty 104°F.
Max medium density 0.0397 Lbs/inch³.
pH of the pumped medium 5-8.
Volute with free passage 2 3/8". Max no. of starts 30/hour.
Max impeller diameter requires half motor or more submersed for continuous duty. (Pump can operate lying down.)

Pump Types

SP 20-1115*/-1124 3-phase
SP 20A-1115*/-1124 3-phase (built-in float switch, excl. 575V)

* Impeller diameter for duty with low water level or intermittent dry running.

Electric Motor

3-phase squirrel-cage induction motor, 60Hz.
Service factor 1.1. Class F insulation.
Dual voltage stator 230/460 V (single voltage contactor coil)
Motor rating P₂: 3 Hp. Speed: 3460 rpm
D.O.L. start with built-in contactor

Voltage, V	208	230/460	575
Nominal current, A	9.1	8.2/4.1	3.3

Power Cable

Heavy duty power cable for submersible pump applications
65 ft AWG 14/4 SOOW (UL, CSA, MSHA)

Motor Protection

Built-in thermal switches in the stator windings (284°F, ±5), connected to built-in contactor.

Shaft Seal

Double mechanical seal in oil bath.

Primary seal: Silicon carbide on silicon carbide
Secondary seal: Stainless steel on antimony treated carbon

Bearings

Upper bearing: Single-row deep groove ball bearing
Lower bearing: Double angular contact ball bearing

Materials

Motor housing:	Aluminium	ASTM
Handle, fasteners:	Stainless steel	AISI 304
Rotor shaft:	Stainless steel	AISI 420
Volute, impeller:	Nodular cast iron	ASTM A 536-80: 60-40-18
O-rings:	Nitrile rubber	

Discharge Connections

2 1/2", 3", 4" hose connections
3" (standard), 4" NPT threaded connections

Weight (without cable)

64 lbs

Options and Accessories

Zinc anodes. Surface protection coating
Electronic motor supervision. Starter and control units.
Automatic level control unit. PumpFloater. Service kit
Discharge connection accessories and hose

