

Submersible sludge pump

SP 50

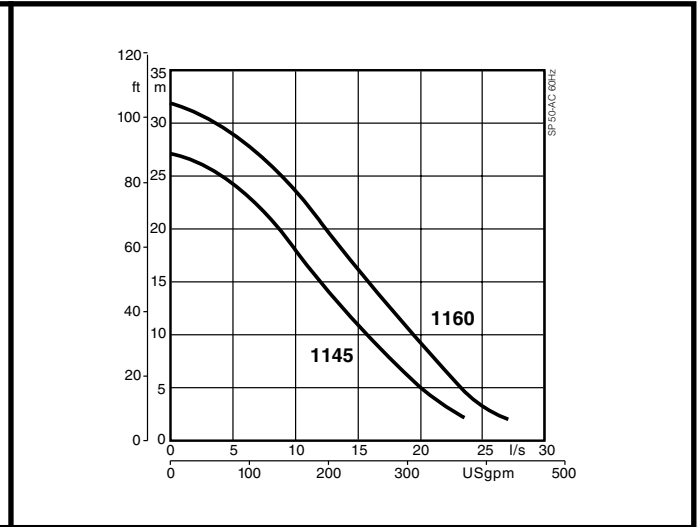
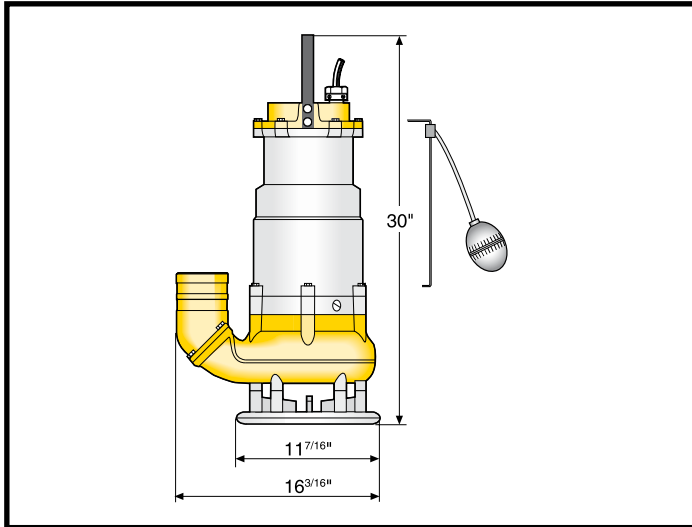

SP50.02.0906.US 60 Hz
The manufacturer reserves the right to alter performance, specifications or design without notice.

Specification

Electric submersible pump.
Maximum submergence: 65 ft. Protection class IP 68.
Max temperature of pumped medium at max power input and continuous duty 104°F.
Max medium density 0.0397 Lbs/inch³.
pH of the pumped medium 5-8.
Volute with free passage 2 9/16". Max no. of starts 30/hour.
Max impeller diameter requires half motor or more submersed for continuous duty. (Pump can operate lying down.)

Pump Types

SP 50-1145*/-1160 3-phase
SP 50A-1145*/-1160 3-phase (built-in float switch, excl. 575V)

* Impeller diameter for duty with low water level or intermittent dry running.

Electric Motor

3-phase squirrel-cage induction motor, 60Hz.
Service factor 1.1. Class F insulation.
Dual voltage stator 230/460 V (single voltage contactor coil)
Motor rating P₂: 8 Hp. Speed: 3400 rpm

Voltage, V	208	230/460	575
Nominal current, A	24	22/11	8.8

Power Cable

Heavy duty power cable for submersible pump applications
65 ft AWG 8/4 W (UL, CSA, MSHA), 208, 230, 460 V
65 ft AWG 12/4 SOOW (UL, CSA, MSHA), 575 V

Motor Protection

Built-in thermal switches in the stator windings (284°F, ±5), connected to built-in contactor.

Shaft Seal

Double mechanical seal in oil bath.

Primary seal: Silicon carbide on silicon carbide
Secondary seal: Stainless steel on antimony treated carbon

Bearings

Upper bearing: Single-row deep groove ball bearing
Lower bearing: Double angular contact ball bearing

Materials

Motor housing: Aluminium
Handle, fasteners: Stainless steel
Rotor shaft: Stainless steel
Volute, impeller: Nodular cast iron
O-rings: Nitrile rubber

ASTM

ASTM AISi10mg
AISI 304
AISI 420
ASTM A 536-80: 60-40-18

Discharge Connections

3", 4" hose connections
3", 4" (standard) NPT threaded connections

Weight (without cable)

119 lbs

Options and Accessories

Zinc anodes. Surface protection coating
Electronic motor supervision. Starter and control units.
Automatic level control unit. PumpFloater. Service kit
Discharge connection accessories and hose

