

Richter Self-Priming Chemical Centrifugal Pumps

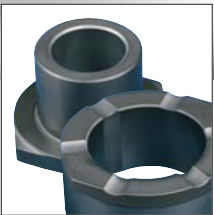
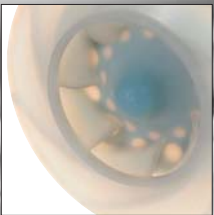
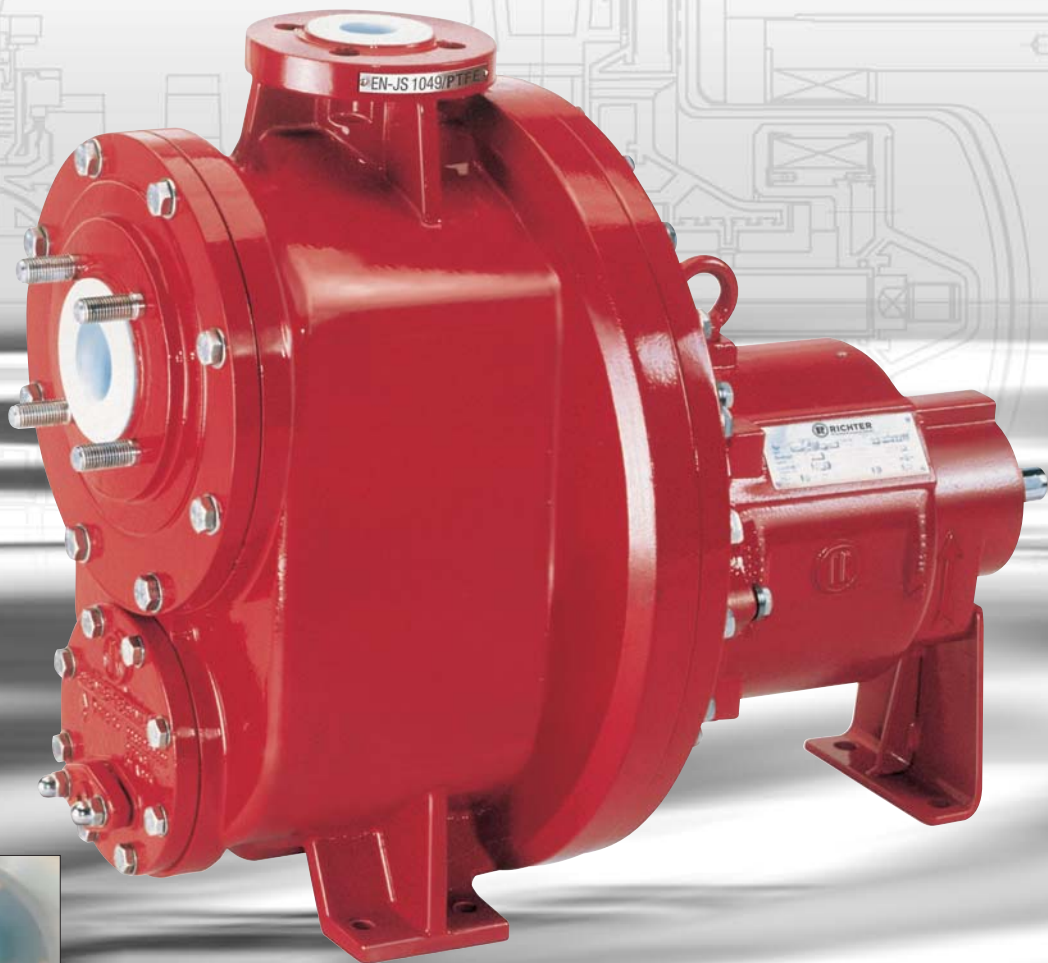

Magnetic drive and
mechanical seal designs

Primes against
18 m (59 ft) WC back pressure

Corrosion-resistant
PFA/PTFE

Richter self-priming chemical centrifugal pumps

The self-priming pump from Richter primes automatically with the suction line empty. Feed tanks are not required!

Suction lift, delivery head and back pressure compatibility govern the performance of a self-priming pump. The Richter pump permits a much greater application range than is possible with standard lined pumps of this type (see page 4).

Top entry vessels, tankers and sumps can be emptied without risk. Bottom drain nozzles below the liquid level can be dispensed with. High-maintenance, large-volume submersible and oscillating pumps can be replaced by this dry-installation pump.

The pump is also suitable for draining waste water sumps.

Air pockets in the suction line are readily transported through the pump even when liquid is being conveyed.

Even primes against 18 m (59 ft) WC back pressure:

Suction lift up to 6 m (20 ft) WC at a specific gravity of $\rho = 1.0 \text{ kg/dm}^3$. Delivery capacities of 1-33 m³/h (4-145 US gpm) up to 40 m (130 ft) LC.

- ① **Pump housing**
 - Ductile cast iron EN-JS 1049/ASTM A395 with thick PFA/PTFE lining
 - No expansion joints required
 - Housing drain connection as standard feature
- ② **„Back pull-out unit“**
 - of the time-tested magnetic drive pump MNK, with eddy-current-free can system and SAFEGLIDE® PLUS SSiC silicon carbide plain bearings (frame-mounted and close coupled pumps)
 - or of the SCK series with internal or external double mechanical seal (frame-mounted pumps)
- ③ **Sturdy design**
 - Bearing pedestal made of ductile cast iron EN-JS 1049/ASTM A395
 - Impeller and plain bearing pedestal/back plate made of PFA/PTFE with stable metallic cores
- ④ **Optimised-flow separation chamber**
 - Short priming phase
 - High efficiency

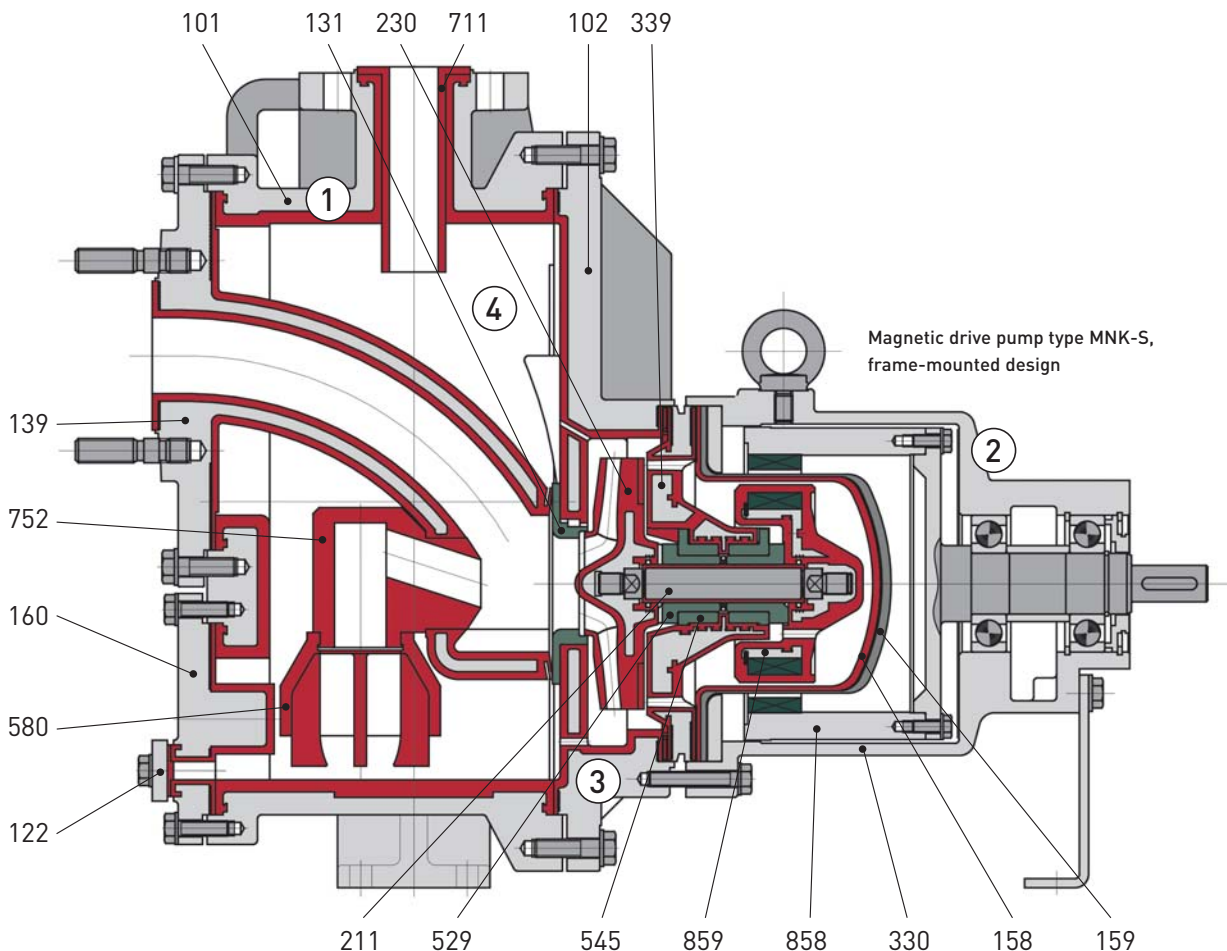

Alternatives to the magnetic drive pump MNK-S of frame-mounted design:

- Mechanical seal pump SCK-S, frame-mounted, with internal or external double mechanical seal
- Magnetic drive pump MNK-SB, close-coupled, with flanged motor

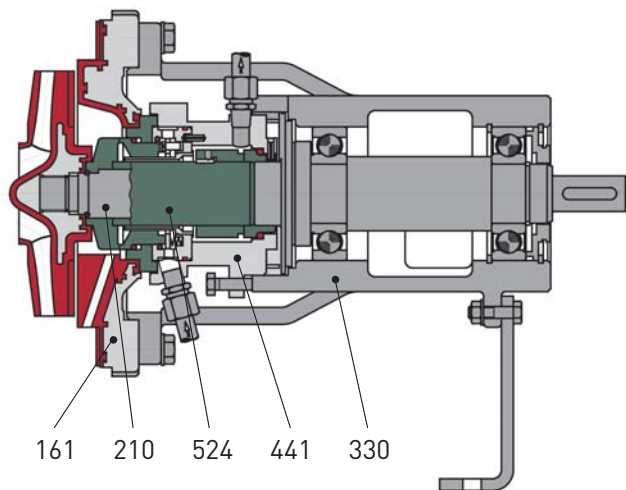

Type SCK-S with internal Richter double mechanical seal

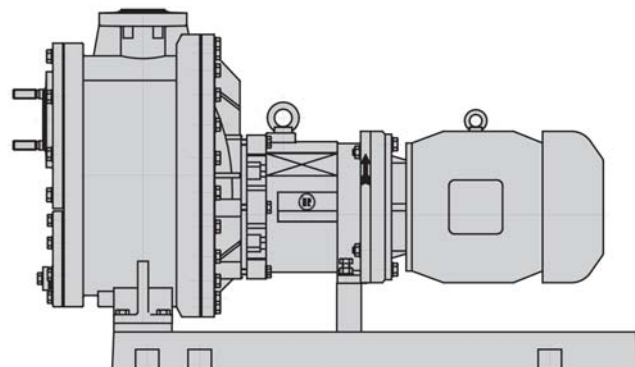

For detailed sectional drawings and descriptions of the basic pumps, refer to the publications SCK or MNK/MNK-B.

Magnetic drive pumps:

- Optional: SAFEGLIDE® PLUS dry-run optimised SSiC plain bearings
- Non-metallic, eddy-current-free cans made of carbon-fibre reinforced plastic with inserts of PTFE, PFA and highly permeation resistant PFA-P, monitor connection on request
- Sturdy, heavy-duty design

Mechanical seal pumps:

- Type SCK-S (heavy-duty design), also for high loads
- Shaft sleeve Al₂O₃, SSiC, Hastelloy etc.

Closed impellers:

- With large metallic core
- Protected against unscrewing in case of start-up in the wrong direction of rotation
- Optimised-flow curved channels

Pressure/temperature range:

- Operating temperature: -60 to +150 °C* (-75 to +300 °F*)
- Operating pressure up to 10 bar (145 psi)
- Design for elevated vacuum (at pump standstill) on request

Solids-containing media:

Consultation with Richter required

* Pump housing filled with medium also at minus temperatures:
Note risk of freezing.
SAFEGLIDE® and Richter = TM Richter Chemie-Technik GmbH

Components and materials

Item	Designation	Standard design
101	Pump housing	Ductile iron EN-JS 1049 (ASTM A395)/PTFE
102	Volute housing	Ductile iron EN-JS 1049 (ASTM A395)/PFA
122	Blind cover	Ductile iron EN-JS 1049 (ASTM A395)
131	Inlet ring	Pure SSiC silicon carbide
139	Feed elbow	Ductile iron EN-JS 1049 (ASTM A395)/PFA
158	Can insert	PTFE, PFA, PFA-P highly permeation-resistant
159	Can	CFRP carbon-fibre reinf. plastic
160	Cover	Ductile iron EN-JS 1049 (ASTM A395)/PFA
161	Back plate	Ductile iron EN-JS 1049 (ASTM A395)/PTFE
210	Pump shaft	Stainless steel
211	Pump shaft	Stainless steel/PFA, PFA-P
230	Impeller	PFA, PFA-P with steel core
330	Bearing pedestal	Ductile iron EN-JS 1049 (ASTM A395)
339	Plain bearing pedestal	Ductile iron EN-JS 1049 (ASTM A395)/PFA, PFA-P
441	Mechanical seal housing	Stainless steel
524	Shaft sleeve	Al ₂ O ₃ , SSiC etc. depending on specification
529	Bearing sleeve	Pure SSiC, on request with SAFEGLIDE® PLUS
545	Bearing bush	Pure SSiC, on request with SAFEGLIDE® PLUS
580	Cap	PTFE
711	Discharge pipe	PTFE
752	Priming valve	PTFE
858	Drive magnet assembly	Steel, permanent magnets
859	Inner magnet assembly	Steel/PFA/PFA-P, permanent magnets

Further technical features

Flanges

- For connection to ISO 7005-2/PN 16 (formerly DIN 2533/PN 16), on request for connection to ANSI or BS

Rolling bearings

- Permanent grease lubrication, oil lubrication on request (for frame-mounted design)

Type code

- with magnetic drive, frame-mounted MNK-S/...
- with magnetic drive, close-coupled MNK-SB/...
- with mechanical seal, frame-mounted SCK-S/...
- PFA/PTFE lining .../F

Weight

- Approx. 170 kg without motor and base plate

Applications

For conveying

- corrosive liquids
- hazardous liquids
- liquids with varying composition (chemical residues, waste water)

Solids-containing liquids:

Consultation with Richter necessary

Emptying tankers

Road, rail

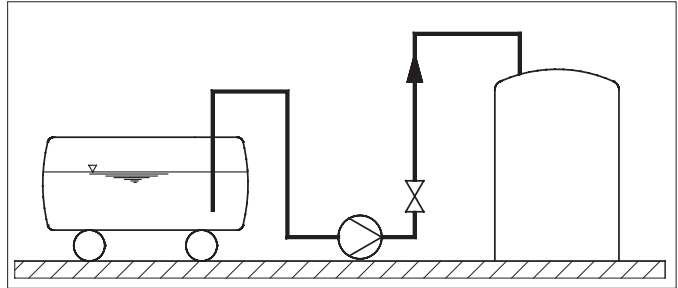

Emptying vessels

Chemical production, chemical tank depot

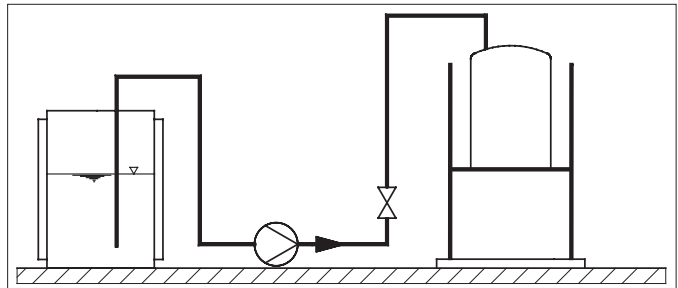

Emptying sumps

Waste water collecting sumps

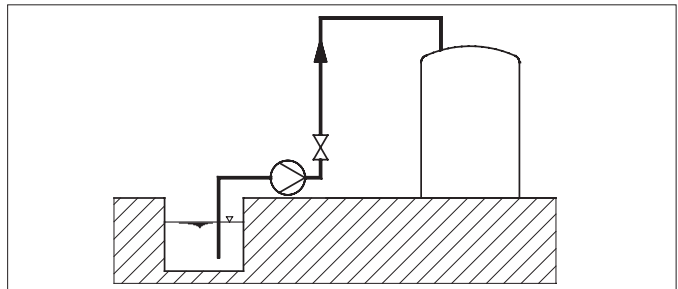

Delivery capacities

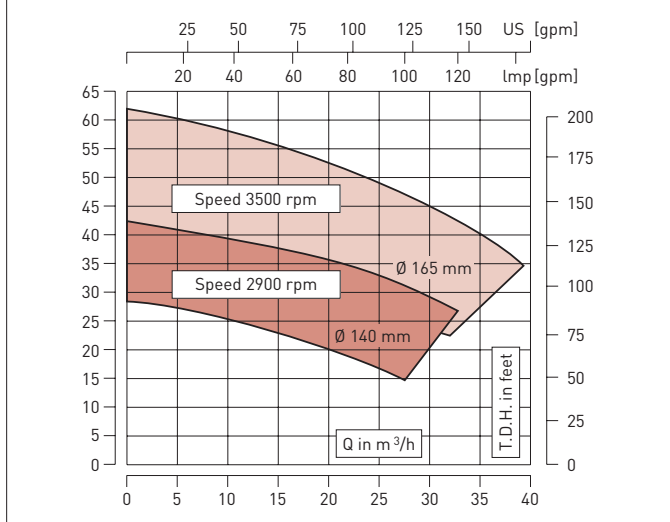

Suction lift, back pressure compatibility

Speed (rpm)	1450	2900	1750	3500
Max. suction lift m (ft) WC at $\rho = 1 \text{ kg/dm}^3$	4 (13.1)	6 (19.7)	6 (19.7)	5 (16.4)
Back pressure compatibility m (ft) WC at $\rho = 1 \text{ kg/dm}^3$	0-6 (0-19.7)	0-4 (0-13.1)	0-18 (0-59)	0-6 (0-19.7)

Presented by:

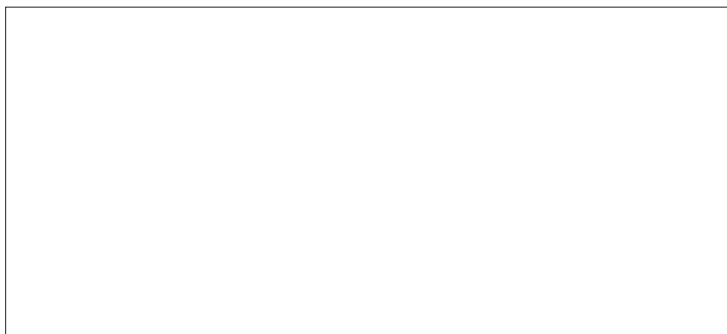

Richter Chemie-Technik GmbH
 Otto-Schott-Str. 2
 D-47906 Kempen
 Tel. +49 (0) 21 52 / 146 - 0
 Fax +49 (0) 21 52 / 146 - 190
 richter-info@richter-ct.com
 www.richter-ct.com