



► The power of proven technology

TAZN



Type Vs4, vertically-suspended,
Line shaft driven pumps
Acc. ISO 13709 (API 610)(VS4)

General design description

TAZN is the sump pump solution for thin or sludgy contaminated liquids. The pump is part of Rodelta Pump International sump-system, a modular programme of single stage centrifugal pumps with a high degree of interchangeability of parts between the different pump constructions.

The TAZN is a range of centrifugal sump pumps, with the pump casing submerged into the liquid and a dry motor construction.

The hydraulic parts of these submersible pumps make use of the pump casings and impellers of the Z ranges, their respective hydraulic fields meeting API 610, (ISO 13709), N or ES ranges are of non API ranges.

The pump is driven by a customer specified or standard IEC flange electric motor 'V1 (IM3011)' placed on a support mounted on the bearing bracket. The power is transmitted through a flexible coupling and a long shaft. The base plate can be executed in a rectangular shape or a standardised ANSI B16.5 or an ASME B16.47 series A or B blind flange.

Technical data

Max. Capacity 300 m³/h,
in case of non API
conditions
1500 m³/h
Max. Head 250 m.l.c.
Max. Temperature 250° C
Max. Speed 3600 rpm
Design pressure up to 16
bar

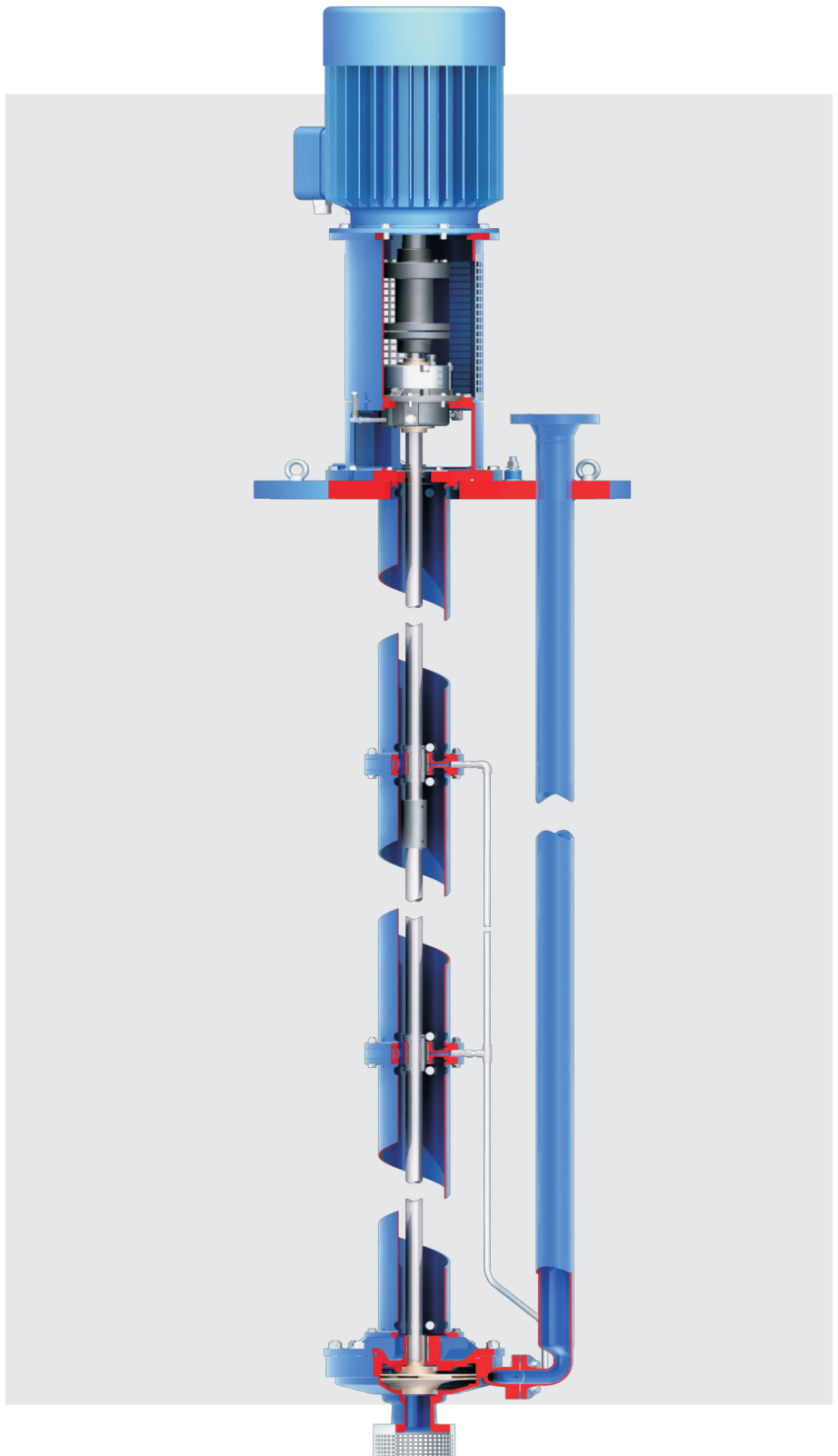

Applications

General industry

TAZN pumps can be used for all kinds of sump duties. Another known application is pumping cooling water when river or lake water is used for chilled cooling water processes.



Off shore

In Off Shore industries TAZN pumps are used for several duties where it is desirable to have the electric motor at distance of the pumped liquid.



Petrochemical industry

TAZN pumps are often used for draining waste water collecting basins. Typical process duties are e.g. drain pump or hydrocarbon condensate.



Features and benefits

Electric motor

- Mounted on a steel made or casted motor support
- Close tolerance fit
- Customer specified or standard IEC flange motor 'V1 (IM 3011)'

Coupling

- Standard fitted with flexible coupling
- Optionally available with membrane coupling or non-sparking coupling
- Coupling guard to prevent entrance to the rotating parts
- Spacer coupling allows disassembly of bearing housing and seal without disassembly and disconnecting of motor

Delivery connection

- Placed on the base plate
- Flanges according to ISO 7005 PN 16, PN 20, PN 50
- Flanges according to ANSI B16.5 150 lbs, 300 lbs

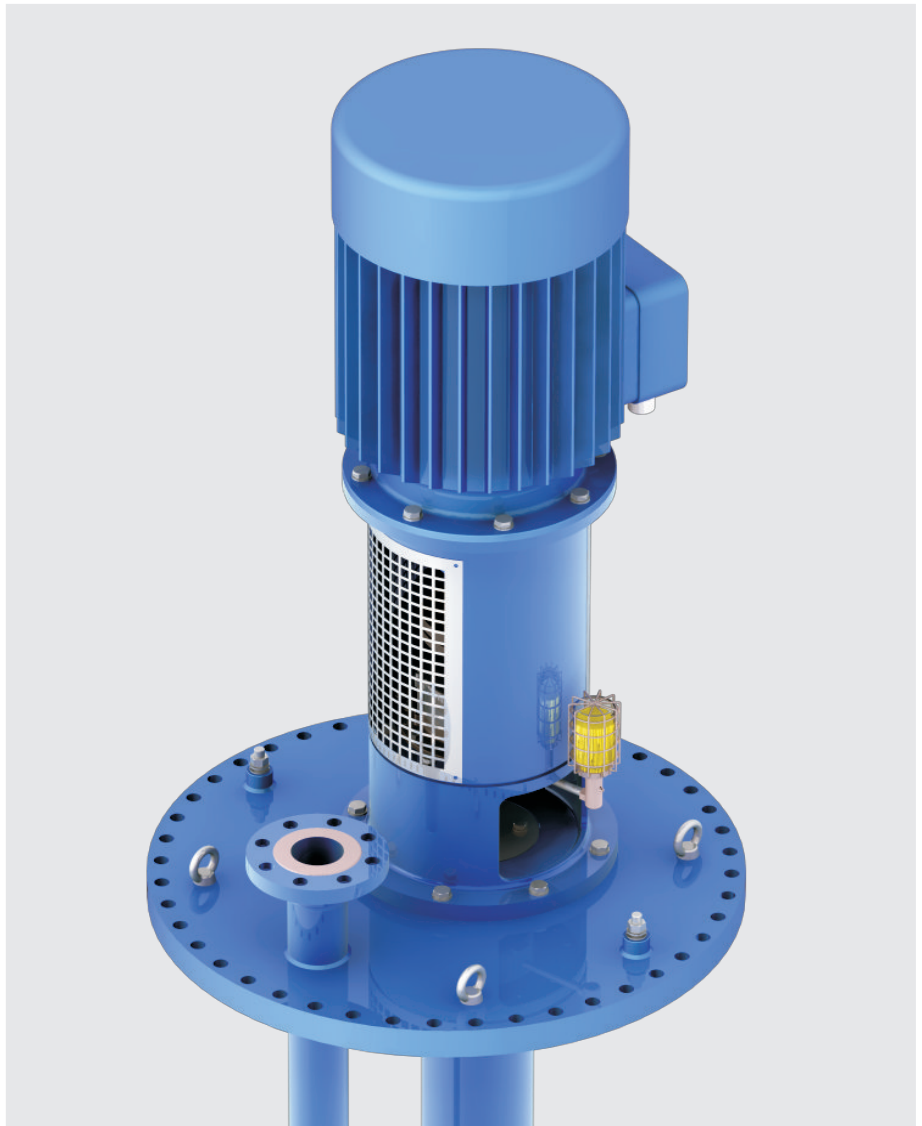

Base plate

- Standard version is a rectangular plate
- Round flange shaped plate is standard for API 610 executions, ANSI B16.5 for flange up to 24 inch, larger flanges acc. ASME B16.47 series A or B, Class 150
- Can be adapted to the size of the pit according to customer specifications
- Lifting lugs for easy maintenance
- Provided with two earthing boss

Column pipe and pump shaft

- Situated below the base plate
- Consisting of one or more parts
- Connects the pump casing with the base plate
- Column pipe protects the shaft
- Supports the intermediate bearings if any
- Sump depth according to customer specification
- Design consists of 4 shaft groups

Benefits

- Available in several materials
- High pump efficiency
- Suited for a wide span of duties
- Easy maintenance
- Compact, space saving construction
- Low maintenance cost
- Designed to meet specific lengths and application requirements
- Base plate designed to meet existing support arrangements

Pump casing/impeller

- Impeller design for low NPSH values
- Available impeller types: closed impeller, half open impeller with wear plate and vortex impeller
- Anti-rotation device at impeller inlet on N range
- Suction strainer
- Optimized hydraulic performance
- Suitable for a wide range of liquids
- Impeller protected from clogging

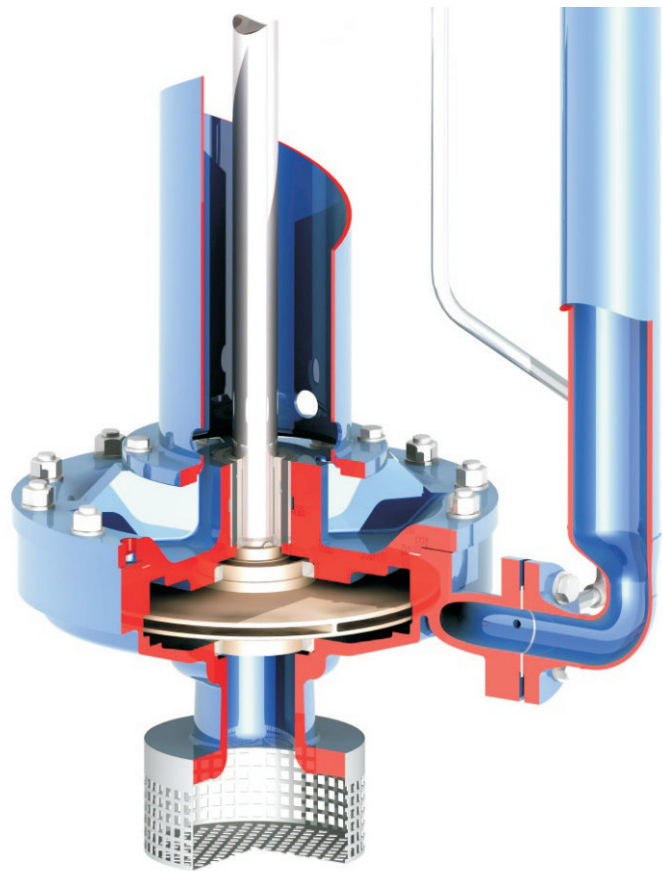

Shaft sealing

Standard the base plate is provided with a V-ring construction for sealing the shaft passage.

For pressure tank applications a mechanical seal or gland packing is optionally available. These seals are available in a wide variety, single

seal as well as double seals can be used with the required seal systems. Dry running seal are also often used.

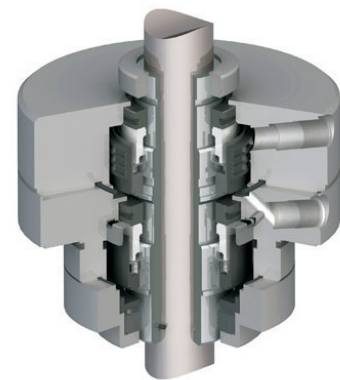
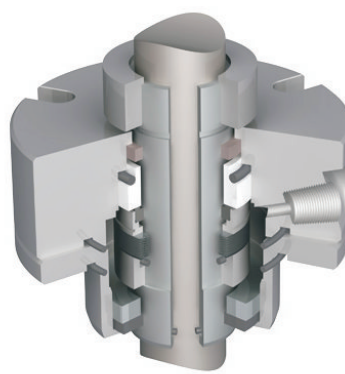
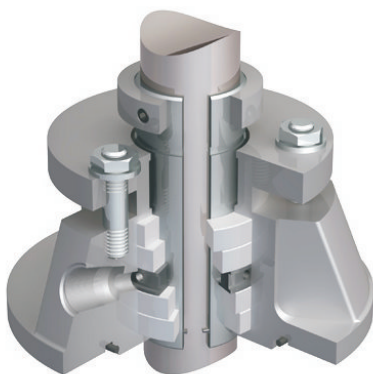

Bearings

- Ball bearing construction
- Two paired angular-contact ball bearings for axial loads on the pump shaft
- Grease or oil lubricated

The 'dry' part of the pump is provided with two paired angular-contact ball bearings, for bearing the axial loads of the pump shaft. The shaft of the 'wet' part of the pump is provided with liquid lubricated slide bearings. The liquid is supplied directly from the discharge nozzle of the pump casing. Or if required through a self cleaning filter or an external source.

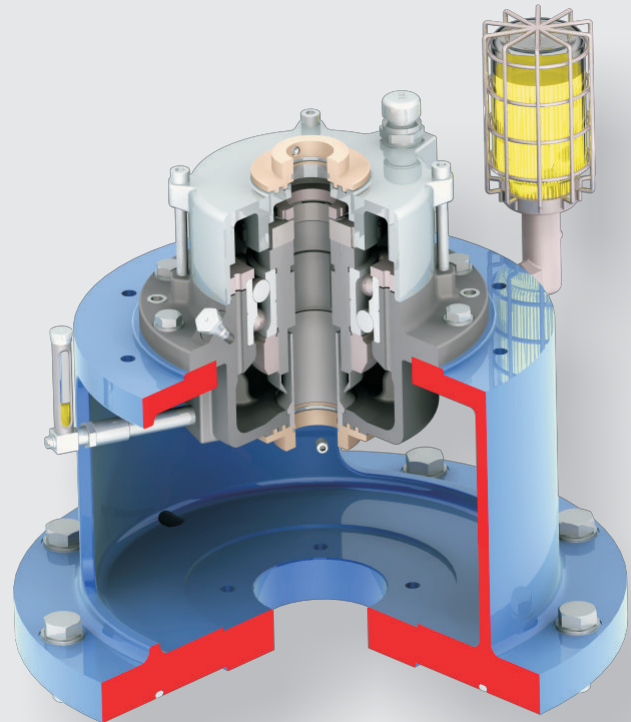

Slide bearings

- Pump shaft provided with slide bearings
- Number of slide bearings depending on the length of the pump shaft
- Carbon filled, liquid lubricated

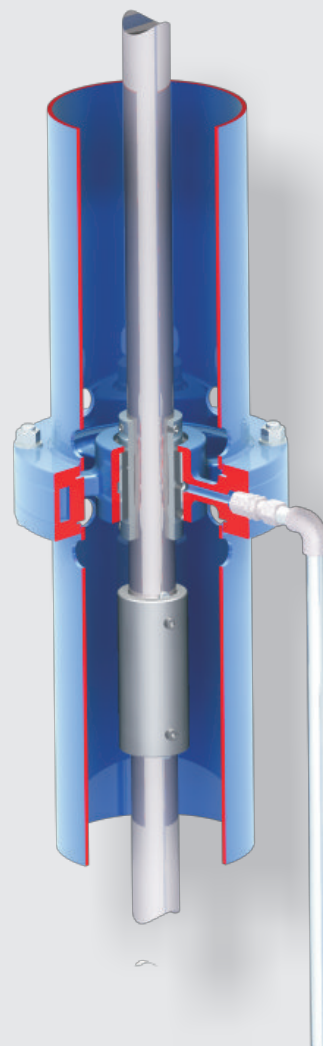

Curves

N=3000 rpm 50 Hz

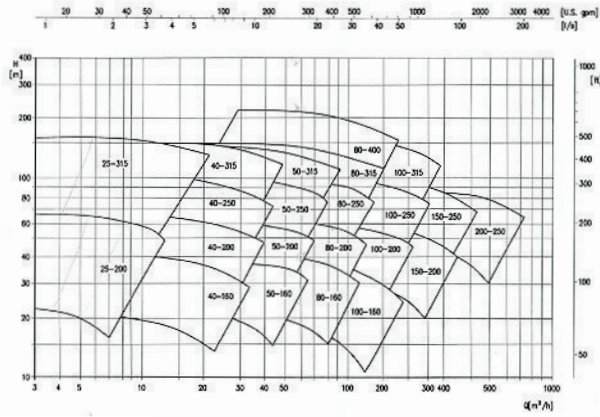

N=1500 rpm 50 Hz

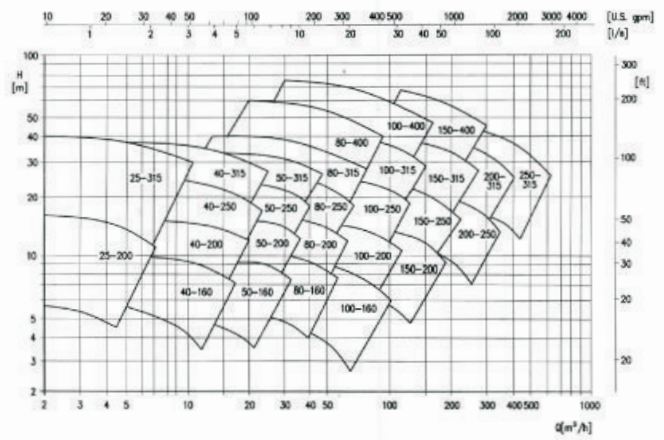

N=3600 rpm 60 Hz

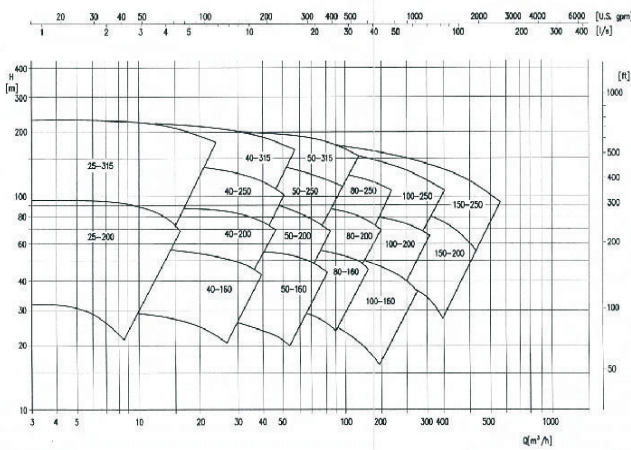

N=1800 rpm 60 Hz

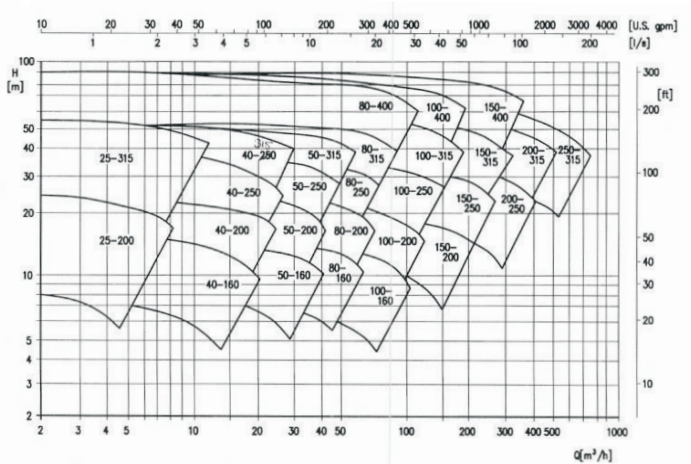

Materials of Construction, TAZN, fully according ISO 13709:2003 (API 610)

Part	Pos. Nr.	Material Classes			
		S-1	S-6	S-8	A-8
Pump casing	1	A 216 Gr WCB	A 216 Gr WCB	A 216 Gr WCB	A 351 Gr CF3M
Impeller	7	A 48-40	A 743 Gr CA15	A 743 Gr CF3M	A 743 Gr CF3M
Case waerrings	50	A 743 Gr CA15 HB 250	A 743 Gr CA15 HB 250	A 743 Gr CF3 + Colm.6	A 743 Gr CF3 + Colm.6
Impeller wearings	51	A 743 Gr CA15 HB 350	A 743 Gr CA15 HB 350	A 743 Gr CF3	A 743 Gr CF3
Shaft	54	A 276 Type 410	A 276 Type 410	A 479 Type 316	A 479 Type 316
Interstage sleeves	62	A 276 Type 410	A 276 Type 410	A 479 Type 316	A 479 Type 316
Interstage bushings	61	A 276 Type 410	A 276 Type 410	A 479 Type 316 + Colm.6	A 479 Type 316 + Colm.6
Case and gland studs	504	A 193 Gr B 6	A 193 Gr B 6	A 193 Gr B 6	A 193 Gr B 6
Case gasket	112	Spiral wound	Spiral wound	Spiral wound	Spiral wound
Discharge pipe / column	35 / 32 / 33	A 106 Gr B	A 106 Gr B	A 312 Type 316 (DIN 1.4401)	A 312 Type 316 (DIN 1.4401)
Column / bowl shaft bushings	83	Carbon	Carbon	Carbon	Carbon
Wetted fasteners / Bolts		A 193 Gr B8M	A 193 Gr B8M	A 193 Gr B8M	A 193 Gr B8M

Rodelta Pumps International B.V.

- | | |
|-------------------------------|-----------------------------|
| ▲ Enschedestraat 234 | ▲ Phone: +31(0)742455200 |
| ▲ 7553 CM Hengelo | ▲ Fax: +31(0)742455201 |
| ▲ PO Box 650, 7550 AR Hengelo | ▲ E-mail: info@rodelta.com |
| ▲ The Netherlands | ▲ Internet: www.rodelta.com |