

# STEP INTO THE FUTURE WITH A 2001 TYPE 10



The leading force behind liquids<sup>SM</sup>



Note: Unit shown includes extra cost options including base, coupling, guard and motor.

- Improved resistance to leakage
- Long-life double mechanical seal with ceramic face stationary seat
- Pressures to 1200 psi
- Materials of construction:
  - Case: Cast iron
  - Gears and Shafts: Case hardened alloy steel
  - Bearings: Hardened cast iron
  - Seals and O'Rings: EPDM
  - Other materials available upon request

Since 1958, Roper Pump Company has been involved in supplying positive displacement pumps for the lacquer injection systems in the can manufacturing process. Over the last 37 years, the units have evolved to meet the needs of the manufacturer. Roper has taken the next step with the introduction of the 2001 Type 10.

Rated at 1200 PSI while pumping 2-5 GPM, the 2001 Type 10 is fitted with a proprietary seal face which greatly reduces the chance of leakage.



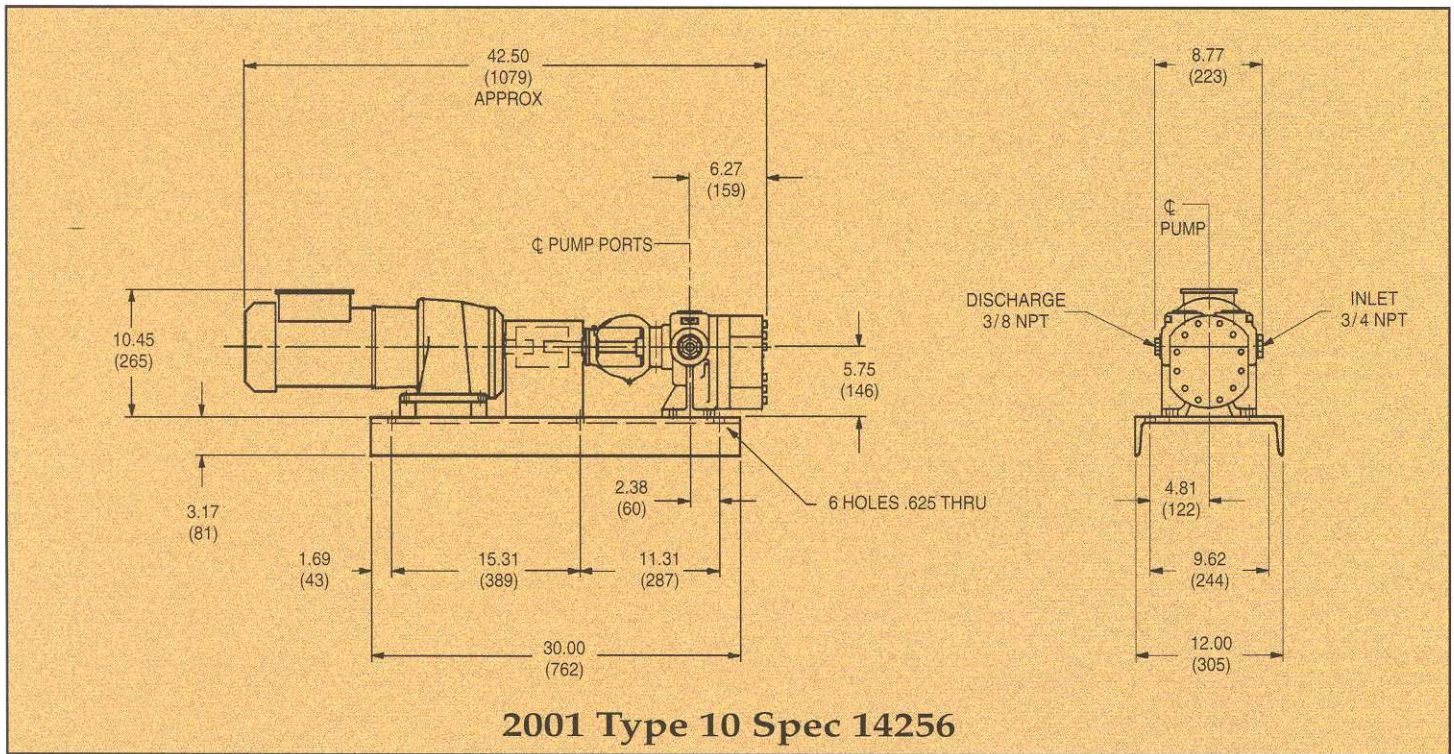
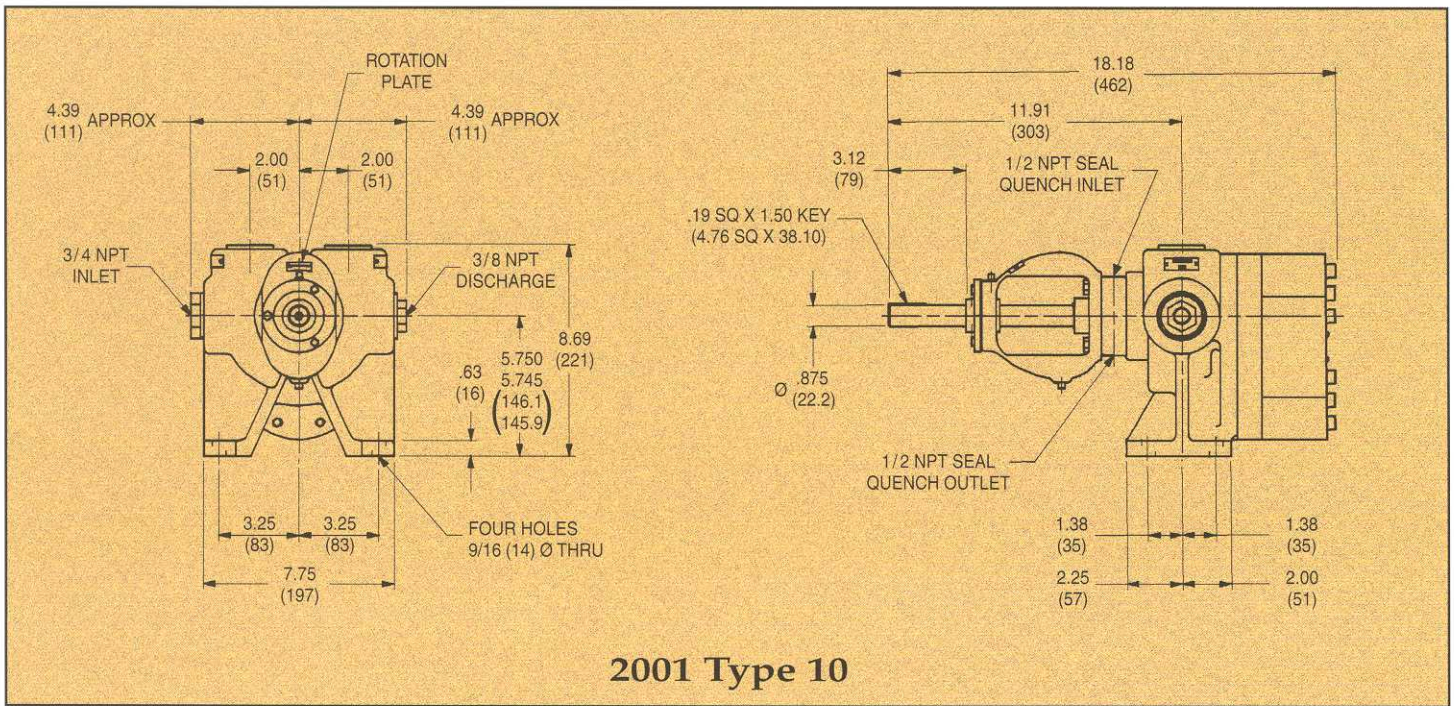

Distributed by:



**Roper Pump Company**

P. O. Box 269 • Commerce, GA 30529  
 Phone: 1-800-944-6769 • Fax: (706) 335-5505

**Roper Industries (Europe) Ltd.**

Registered in England 2440540  
 Western Way • Bury St. Edmonds • Suffolk IP33 3SZ • England, UK  
 Phone: 441 284 760406 • Fax: 441 284 760256 • Telex: 81283

**Roper Industries (Singapore)**

230 Orchard Rd. • #09-230 Faber House • Singapore 0923  
 Phone: (65) 235 1509 • Fax: (65) 235 8869