



S C E

**Heavy Duty, Single Stage, Overhung,
API 610 Process Pump**



SCE

Process Pump

For over 50 years the name Ruhrpumpen has been synonymous worldwide with innovation and reliability for pumping technology.

The SCE is a heavy duty, single stage, overhung process pump built in accordance with the Last Edition of API 610.

The SCE is ideally suited for all refinery and petrochemical plants, oil fields and pipelines, as well as offshore, marine and dock services.

The SCE process pump has a hydraulic range unequalled in the industry.

Qualified specialists in all departments ensure that the pumps and equipment from our facilities are able to operate under the most severe conditions.

Intensive research and development ensures that the products of Ruhrpumpen are continuously improved to meet the latest technical requirements.

It is only possible to achieve these aims by means of highly sophisticated CNC controlled machines in our modern machine shop, supplemented by our test and development departments as well as the latest industry standard inspection and control procedures. All in our ISO 9001 certified facilities.

The application of modern, reliable methods, data processing and sophisticated software with high performance, state of the art IT offers our customers high reliability and speed in all working processes, from planning and production to the providing of spare parts.

The instant availability of spare parts, together with first class service, ensures customers that they have selected the right partner.

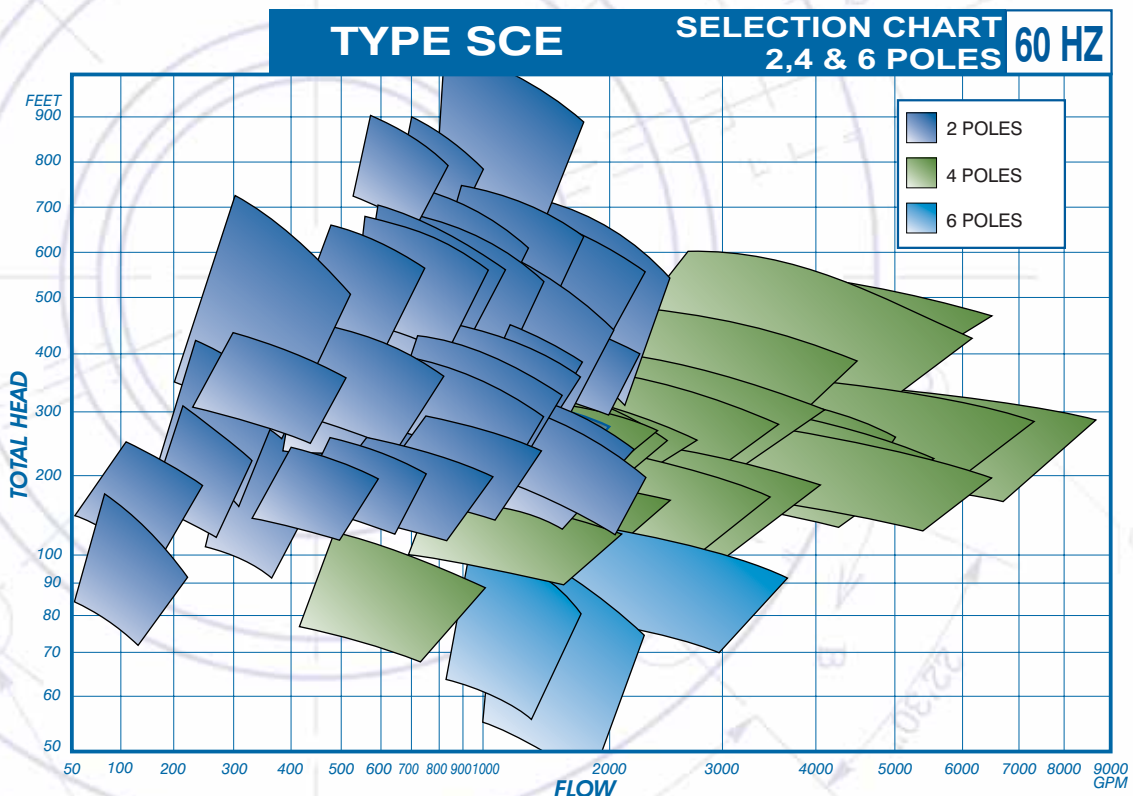

Fully Compliant with API 610, 9th Edition



Optional cutter screw coke crusher design

Bearing Configurations

- ✓ Deep groove radial and duplex thrust bearings for maximum bearing life.
- ✓ Special bearing arrangement available for high suction pressures.

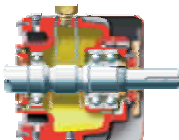

Fan and water cooled bearing feature

Bearing Lubrication and Cooling Options

- ✓ Oil mist and oil purge for continuous bearing lubrication.
- ✓ Fan cooling for high ambient temperatures.
- ✓ Removable water jacket to insulate radial bearing from process temperature.

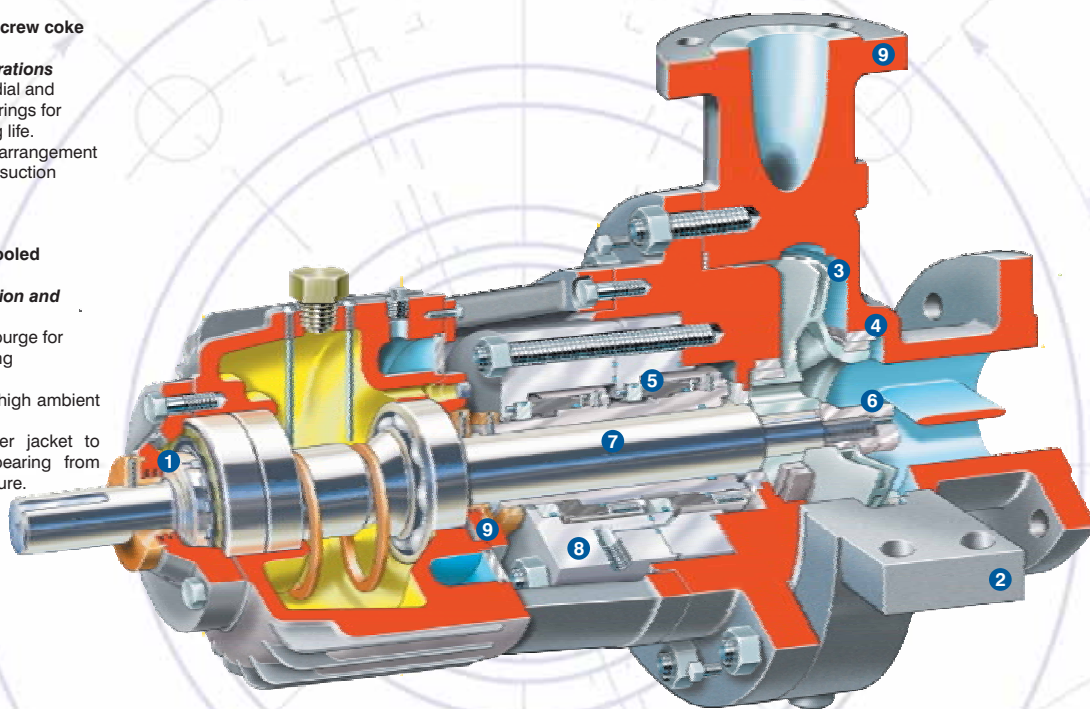

- 1 The standard design incorporates special enhanced Inpro/ Seal™ bearing isolators with cooling action.
- 2 The pump casing has centerline support feet integrally cast with the case for equal thermal expansion or contraction.
- 3 The impeller is closed, single suction, statically and dynamically balanced.
- 4 Renewable front and back impeller wear rings are standard.
- 5 The gland utilizes four studs to insure a secure fit when mechanical seals are utilized. All studs used in the sealing gland and bearing bracket covers are ASTM A 193 Gr B7.
- 6 The impeller is keyed to the pump shaft and positively locked in place by a cap nut.
- 7 The shaft is designed with a larger diameter and minimum length to reduce shaft deflection. The stepped shaft positively positions impeller and sleeve and permits free expansion at high temperatures. Gasketed shaft sleeve positively seals and eliminates leakage under the sleeve. The sleeve extends through the gland.
- 8 The seal chamber is larger than API dimensions and will accept all mechanical seal arrangements.
- 9 Standard flanges are 300# RF, finish per ANSI B16.5.

Product Description

- ✓ Horizontal, single stage, centerline mounted, back pull-out, radially split, end suction, top discharge, heavy duty centrifugal process pump.
- ✓ Process Design.
- ✓ Single Stage, Single Suction.
- ✓ Designed to meet API 610 pump standards, Last Edition.
- ✓ Options: top suction, top discharge nozzles.

Note: 1"-3" discharge nozzles are single volute
4" and above are double volute.

Broad Application Range

- ✓ Temperatures from -50°F (-46°C) to 850°F (450°C).
- ✓ Pressures to 667 psi (4600 Kpa).
- ✓ Flows to 9000 gpm (2045 m³/h).
- ✓ Petroleum refining, production and distribution.
- ✓ Petrochemical.
- ✓ Heavy-duty chemical.
- ✓ Gas industry services.
- ✓ Utilities.

Performance Data

Capacity	To 9000 U.S. gpm	2045 m ³ /hr.
Head	To 1100 feet	335 m
Flange size	1" to 10"	Discharge
Pressure	To 667 psig	4600 KPa
Temperature	-50°F to 850°F	-46°C to 450°C

Other Ruhrpumpen Products

**API 610
Between Bearings
Radial Split Single Stage**

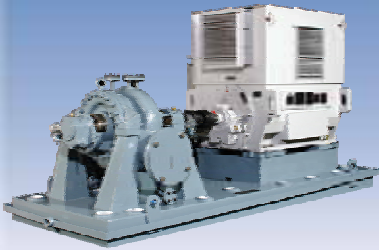

**API 610
Between Bearings
Radial Split Single Stage**

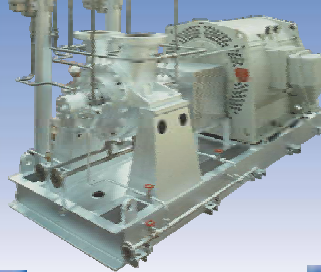

**Split
Case**

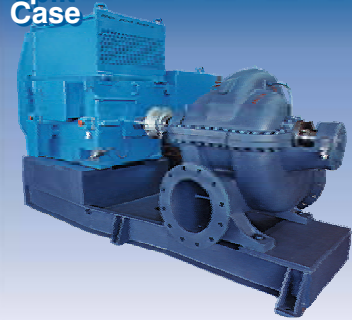

**Axially
Split**

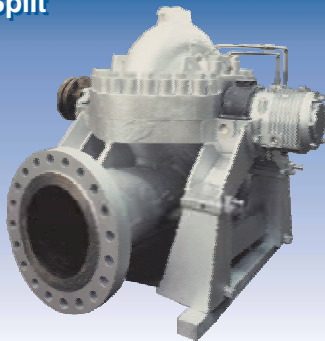

**UL/FM
Firewater Pumps**

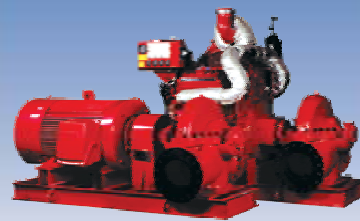

Ruhrpumpen, Inc.

4501 South 86th East Ave.
Tulsa, Oklahoma 74145 USA
Phone: 918-627-8400
Fax: 918-624-2471
e-mail info@ruhrpumpen.com

Ruhrpumpen GmbH

Stockumer Strasse 28 58453 Witten/Germany
P.O. Box 63 09 58432 Witten/Germany
Phone: (+ +49) 23 02/661-03
Fax: (+ +49) 23 02/661-3 03
e-mail: info@ruhrpumpen.de

Ruhrpumpen, S.A.

Níquel No. 9204 Ciudad Industrial Mitras,
García, N.L. México 66000
Phone: (+52)(81) 8158-5500
Fax: (+52)(81) 8158-5501
e-mail: info@corporacioneg.com

www.ruhrpumpen.com

e-mail: info@ruhrpumpen.com



Specialist for Pumping Technology

A
Corporación 
Company

For more information:

