

## OPERATING LIMITS

Flow rates up to:	6 m <sup>3</sup> /h
Heads up to:	6.5 m
Max. operating pressure:	10 bar
Max. loop temperature:	+ 60°C*
Max. ambient temperature:	+ 40°C
Water hardness (TH):	35°F
ND ports:	15 to 25

\* + 110°C for the circulator

# NSB/NSB-S/DSB

## SINGLE AND TWIN-HEADS CIRCULATORS

**Bronze and stainless steel casings**  
**Domestic secondary hot water range**  
**50 Hz**

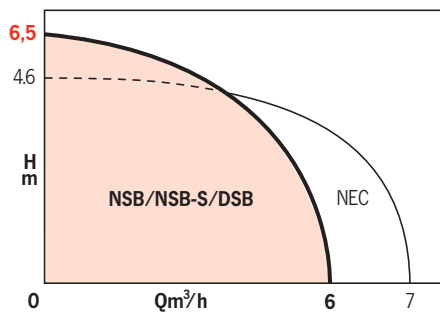

## APPLICATIONS

Hot water accelerated circulation in distribution loops.  
 • Industrial systems.  
 • Solar circuits.

• Domestic installations and small commercial installations.

Hot water on opening tap.



- **DSB33-25B:** distance between ports = 180 mm ØG1¼.  
 DSB33-25B with "BAG-ADAPT"  
 distance between ports = 180 mm ØG2



- **NSB 25-20B with (a) & without counter flanges (b):**  
 a) assembled with CBOV3342, perfectly interchangeable with the old references SA15 (distance between ports = 158 mm)

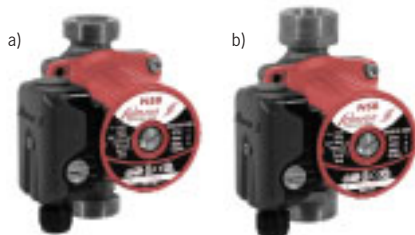

- **NSB 15-15B with and without adapters:**  
 a) NSB 15-15B = distance between ports 130 mm ØG1  
 b) NSB 15-15B with kit150 = distance between ports 150 mm ØG1¼. Dual assembly possible.



DSB33-25B "Anti Legionnaire" Infection System (ALS)



NSB-S: stainless steel or NSB...B: bronze casing  
 DSB: bronze casing - a choice of material compatible with network

# NSB/NSB-S/DSB

## ADVANTAGES

- **Water quality preserved:**
  - constant water renewal in rotor chamber,
  - choice of materials compatible with network; DSB "Anti legionella" Infection System.
- **Anti-blocking system guaranteeing exceptional resistance to hard water, up to 35°F.**
- **Easier choice:**
  - 3 speed,
  - adaptation accessories enabling replacement without altering the piping.
- **DSB: continued availability of an emergency circulator with perfect irrigation of the domestic hot water loop due to the ALS system. Simultaneous operation possible in the case of increase in flow rate.**
- **Automatic permutation possible through the Pump Management Unit (see specific instructions: MGP N° 300-8).**
- **For NSB-S: integrated and automatic motor overload protection.**

## DESIGN

- **Hydraulic part**  
Casing with threaded ports for direct assembly on piping:
  - in bronze for assembly on copper piping (NSB and DSB)
  - in stainless steel for assembly on galvanized piping (NSB-S).
 Rotating parts in contact with water in anti-corrosive material.  
Stainless steel ring at impeller seal.  
DSB: single bronze casing with suction and discharge ports on the same axis.  
DSB: check valve integrated with the "Anti legionella" Infection System.

- **Motor**  
3 speed (NSB 05-15B single speed).  
Manual speed change.  
Wet rotor and self-lubricating bearing bushings.  
Capacitor incorporated in the terminal.
- Speed : see table
- Winding 1-phase : 230 V
- Frequency : 50 Hz (option 60 Hz)
- Insulating category : F (155°C)
- Conformity : CE
- NSB-S Specific : IP 44
- Immunity : EN 61000-6-2
- Emission : EN 61000-6-3

## PRESELECTION CURVES AT MAXIMUM SPEED

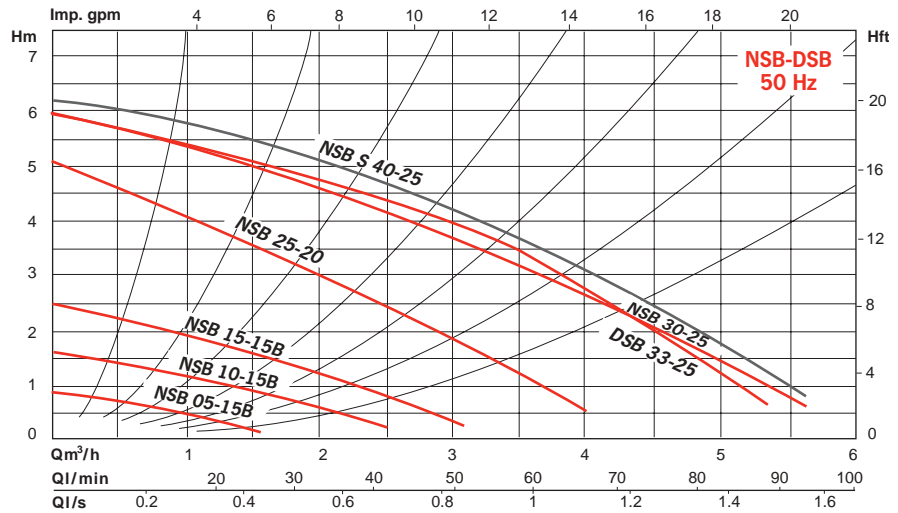

## FITTING POSITIONS

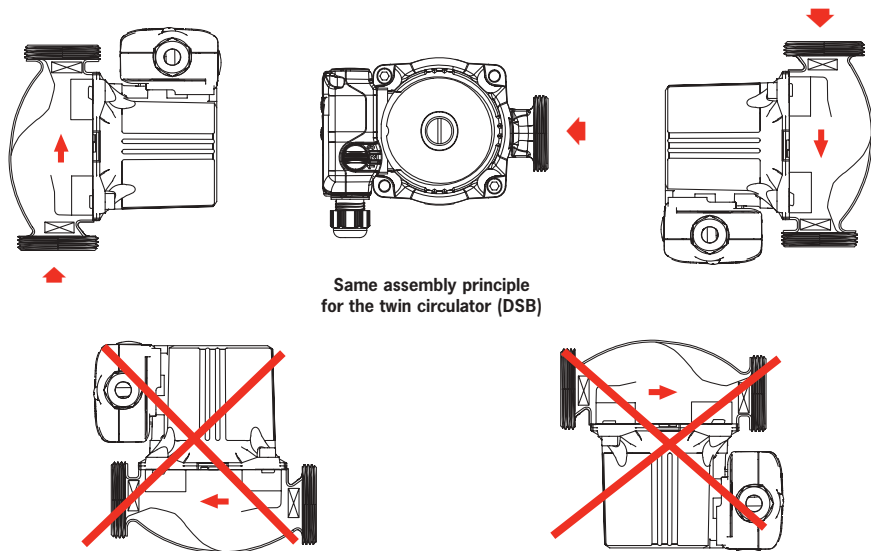

## IDENTIFICATION

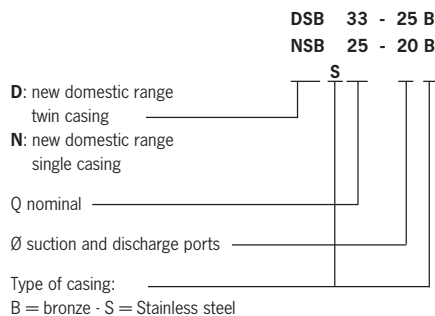

## STANDARD CONSTRUCTION

Main parts	Material
Pump casing	NSB...B Bronze
	NSB-S Stainless steel
	DSB Bronze
Impeller	Composite material
Impeller shaft	Ceramic
Bushings	Graphite
Can	Stainless steel
Leaktight seals	EPDM

## SECTIONAL DRAWINGS

### NSB-S

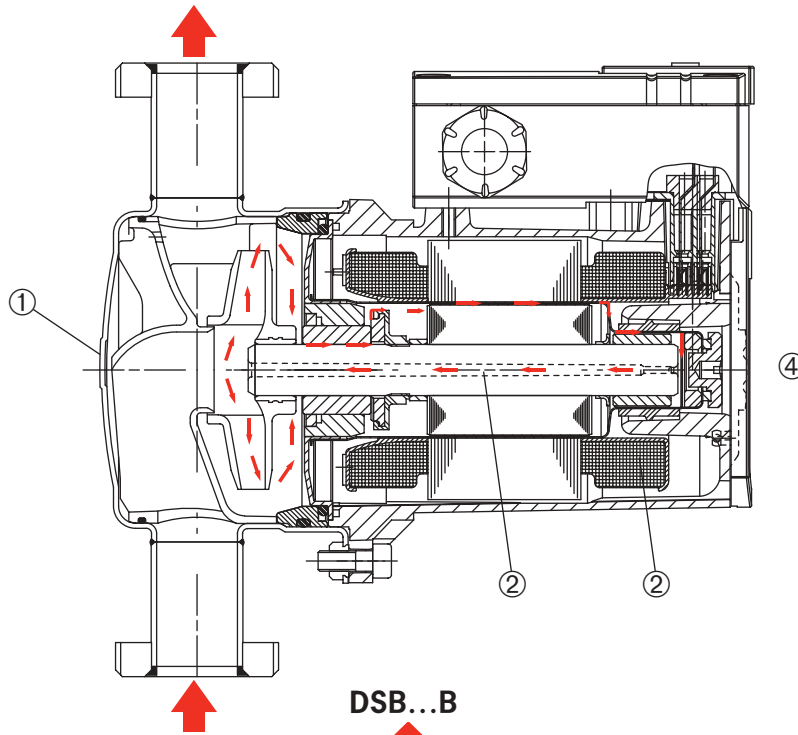

### INTERIOR OF THE SINGLE CIRCULATOR

- ① - Stainless steel casing proposed on wide diameter apparatus - compatibility with galvanized steel piping.
- ② - Ceramic shaft:
  - constant renewal of water,
  - temperature maintained above the threshold of lime precipitation.
- ③ - Stainless steel cartridge and rotor with a stainless steel sleeve.
- ④ - Integrated and automatic motor overload protection for running security.

### DSB...B

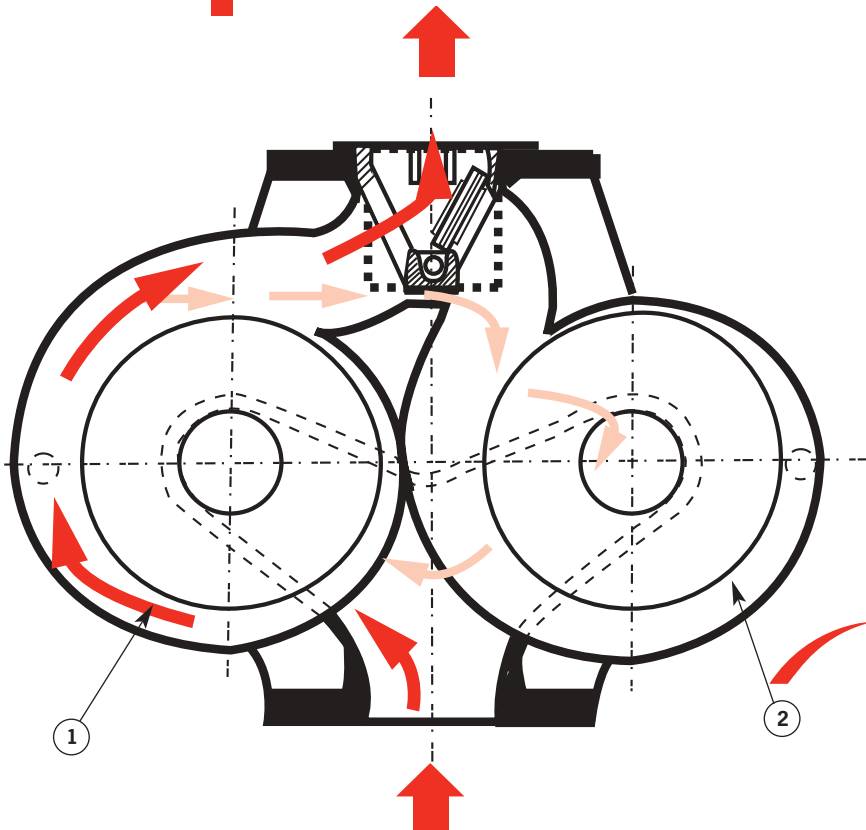

### TWIN CIRCULATOR: PRINCIPLE OF THE ANTI-LEGIONELLA INFECTION SYSTEM (ALS) (Patent pending).

The ALS gives constant circulation and renewal of water in the hydraulic casing of the emergency circulator when its motor is shut down:

- no stagnant water (no ox-bow phenomenon);
- maintaining a steady temperature between the two circulator units which avoids formation of "legionella" infection in hot water installations adjusted to a normal operating temperature.

- ① - Casing with motor in operation.
- ② - Casing with motor shut down.

- Water circulation in the domestic hot water loop.
- ALS water circulation.

# NSB/NSB-S/DSB

## HYDRAULIC PERFORMANCES

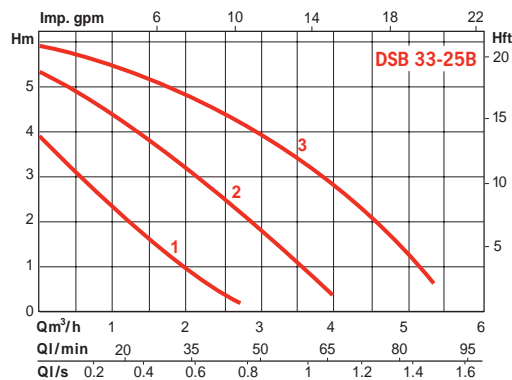
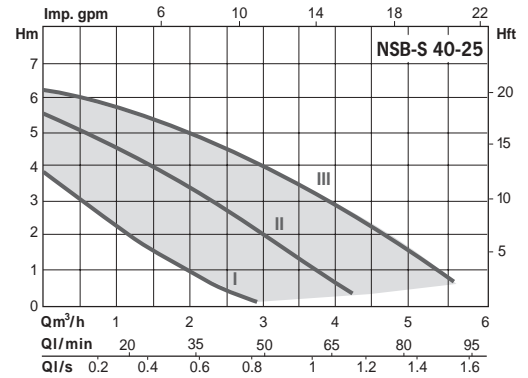
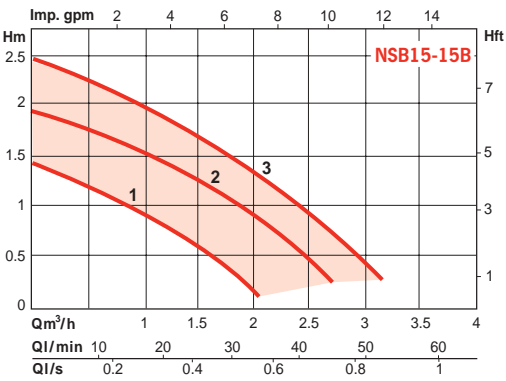
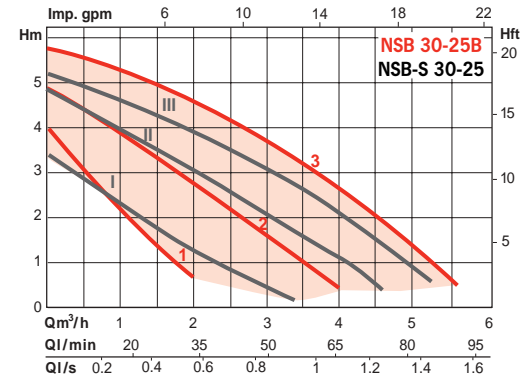
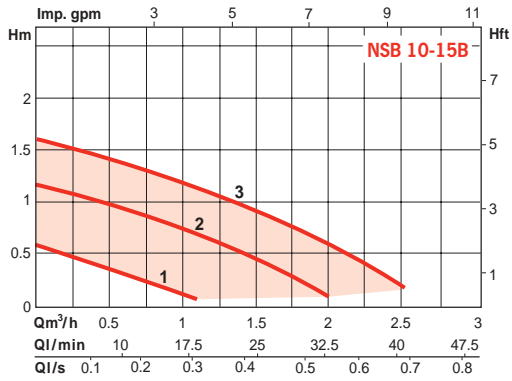
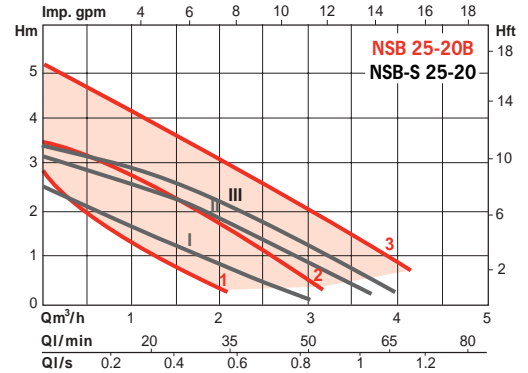
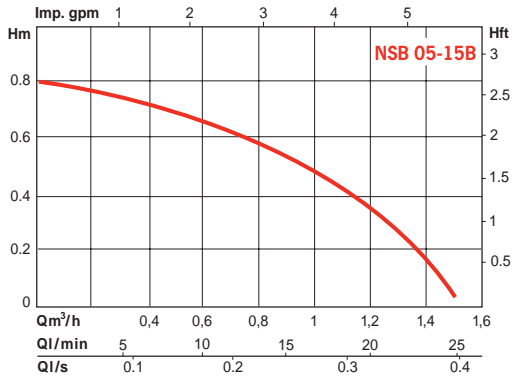

## INSTALLATION DIAGRAM

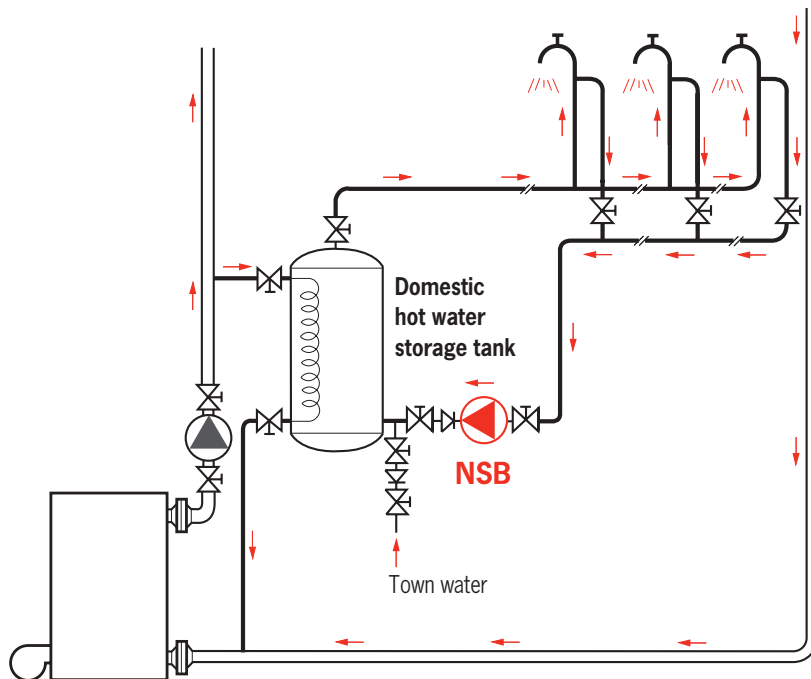

### DOMESTIC HOT WATER DISTRIBUTION LOOP

- Loop maximum temperature 60° C (according to Standard Local Rules)
- Recommended flow speed between 0.5 and 1 m/s maximum
- Circulator assembled on the backflow of the loop, after the drawing points.

# NSB/NSB-S/DSB

## ELECTRICAL DATA AND DIMENSIONS

NSB-B bronze casing

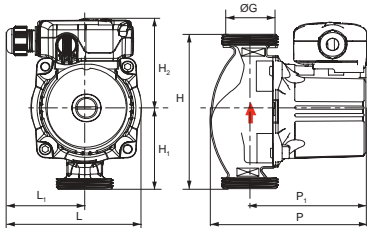

NSB-S stainless casing

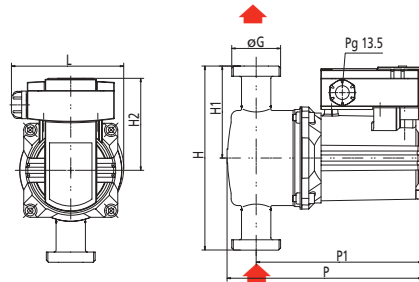

DSB bronze casing

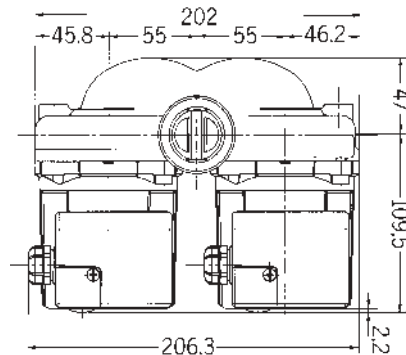
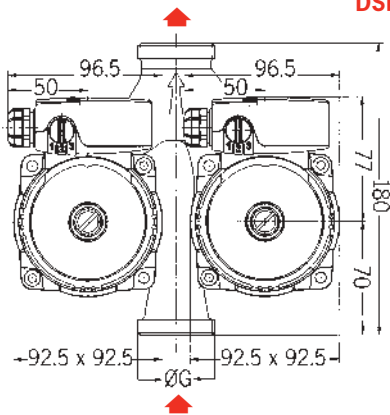

## FEATURES

### a) Electrical

- All types in single-phase 230 V, 50 Hz with capacitor integrated in the terminal box.

### b) Installation

- Motor shaft always horizontal.
- Connection with the network  
Depending on the model:
  - Copper unions (R) to be welded, or brass unions to be screwed (RU brass) on copper piping,
  - Steel unions to be screwed (RU) on galvanized steel piping.

### c) Packaging

- With gaskets, without union.

### d) Maintenance

- Standard exchange of the assembly.

## OPTIONS & ACCESSORIES

- Unions.
- NP6 oval screw-on counter flanges to be screwed.
- Check valve.
- Isolating valves.

ORDER REFERENCE	M O T O R					P U M P							mass	Ø G	connection by	T. box standard assembly
	speed selector position	speed rpm	P1 W	nominal amperage A	capacitor capacity µF	H mm	P mm	L B.A.B. mm	L1 mm	P1 mm	H2 mm	H1 mm				
NSB05-15B	-	1850	30	0.15	1.6 x 400 V	130	129	96	74	96	73	65	2	G1	R2022 or RU1521 brass	9h
	1	1000	20	0.10												
NSB10-15B	2	1600	32	0.15	1.6 x 400 V	130	130	96	74	96	74	65	2	G1	R2022 or RU1521brass	9h
	3	2000	48	0.22												
	1	1700	27	0.12												
NSB15-15B	2	2200	39	0.18	2 x 400 V	130	130	96	74	96	74	65	2	G1	R2022 or RU1521 brass	9h
	3	2500	56	0.24												
	1	1700	27	0.12												
NSB25-20B	1	1000	45	0.20		158	132	123	77	96	77	79	2.4	G1/4	R2022/2628 or RU2027 brass or CBOV3342	9h
	2	1450	66	0.29	2.6 x 400 V	150*										
	3	1950	89	0.39												
NSB30-25B	1	1150	70	0.32		180	145	96	77	109	77	90	2.8	G1/2	RED2027 brass RU2634 brass	12h
	2	1650	102	0.46	2.6 x 400 V											
	3	2300	114	0.50												
NSB-S 25-20	1	2100	65	0.35		158	191	110	-	163	90	79	3	G1/4	RU2027	12h
	2	2600	110	0.40	3.7 x 400 V											
	3	2790	105	0.50												
NSB-S 30-25	1	1750	105	0.55		180	191	110	-	163	90	90	3	G1/2	RU2634	12h
	2	2354	140	0.70	5.0 x 400 V											
	3	2670	170	0.85												
NSB-S 40-25	1	1260	120	0.65		180	191	110	-	163	90	90	3.4	G1/2	RED2027 or RU2634	12h
	2	1810	175	0.90	5.0 x 400 V											
	3	2390	200	1.00												
DSB33-25B	1	1400	70	0.32										G1/2	RED2027 or RU2634 brass	12h
	2	2000	101	0.46	3.5 x 400 V											
	3	2500	128	0.56												

\* also available in H = 150 mm Ø G 1 1/4