

OPERATING LIMITS

Flow rates up to:	120 m ³ /h
Head up to:	43 m
Max. discharge pressure:	13 bar up to +140°C 16 bar up to +120°C
Temperature range:	-20° to +140°C
Max. ambient temperature:	+40°C
Flanges ND:	40 to 80

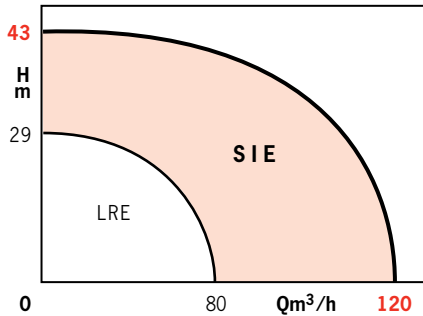

SIE

SINGLE HEAD PUMPS IN-LINE ELECTRONIC CONTROL

Heating - Air conditioning S.H.W. 50 Hz

APPLICATIONS

Pumps designed to circulate cold or hot water free from abrasive residues in heating, hot domestic supply water, cold and iced water systems and irrigation systems. If additives are used, such as glycol or oil, check that the seals are suitable and whether or not the flow rate needs to be adjusted (for a glycol volume of upwards of 10%).

- Approved fluids:
 - Heating water to VDI 2035 ●
 - Service water - chilled/condenser water ●
 - Water/glycol-mixtures¹⁾ ○
 - Heat transfer fluids ○
 - Other media on request ○

Performance

Speed range: 1100 -2900 rpm.
Infinitely-variable speed control.



- Standard design
- Special design at extra cost
- 1) Applies to 20 - 40 % vol. glycol content and up to 40° C fluid temperature.

ADVANTAGES

- **ENERGY SAVINGS**
Pumps duty point optimization.
Up to 50% energy savings compare to standard pumps.
- **NOISE CONTROL**
Whistling and noise elimination at thermostatic valves.
Automatic speed adaptation for comfort needs.
- **RELIABILITY**
The fully automatic running requires neither sensor maintenance nor drain.
Electronic set equipped with non volatile memory for data storage, settings protection in case of electricity shortage.
Protection Index IP 54 for motor/set package in case of dust and humid surroundings. For twin pumps (DIE equipped with 2 IF modules), automatic* permutation without external control.
- **SIMPLICITY**
Only one button controls function choice and settings adjustment.
Adjustments always viewable on LCD screen.

NB

NPSH curves shown are based on tested data. A safety margin of not less than 0.5 m should be added.

STANDARD CONSTRUCTION

Mains parts	Material	
Pump	EN-GJL 250 ³⁾	●
Impeller	EN-GJL 200 ⁴⁾ G-CuSn 5	● ○
Lantern	EN-GJL-250 ³⁾	●
Shaft	1.4122/X39CrMo17-1	●
Mechanical seal	Graphite/Si carbide/EP	●

○ Other mechanical seals on request.

ELECTRICAL DATA

- **Mains power supply**
3~400 V, 50 Hz
3~380 V, 60 Hz
- **Motor**
Three-phase squirrel cage electric motor
Performance and frames to IEC 38
Integrated thermistor sensors (thermistor)
Protection index IP 54 ●
Insulating category F ●
Electronics
Emission EN 61800-3 EN 50081-1
Immunity EN 61800-3 EN 50082-2
Protection differential (FI)
Selective "all current" FI differential circuit breakers are permitted.
(> 300 mA trip rating).
Ident mark: FI 

MOUNTING POSITIONS

- Pipe supported ●
- Bracket or base mounted ○
- Pipe connections ●
- Flanges PN 16/EN 1092-2 ●

PUMP EQUIPMENT

- Pump intergrated Δ P-c mode for constant head control
- Pump intergrated Δ P-v mode for variable head control
- Remote control facility (0 - 10V) for wiring to an external control unit BMS
- Pump integrated setpoint adjustment
- Graphic Display
- Fault reset button
- Off-line centralised operating signal (closed-circuit contact)
- Centralised fault signal (open-circuit contact)
- External On/Off
- "Analogue 0...10V*" input
- Space for IF module (interface for double pumps)

- Standard design
- Special design at extra cost

* See functions charge

- 1) Applies to 20 - 40 % vol. glycol content and up to 40° C fluid temperature.
- 2) Applicable for water/glycol mixtures differing from those referred in 1).
- 3) Previously Ft 25.
- 4) Previously Ft 20.

DESIGN

- **Hydraulic part**
In-line single-stage low pressure centrifuge pump with suction and discharge flanges of the same nominal diameter, with an air-cooled standard IEC motor. NP 16 holed flanges compliant with EN 1092-2. G 1/8 pressure gauge couplings used for the built-in differential pressure sensor.
The pump body has serial bosses designed for a maximum operating pressure of 16 bars. The motor shaft coupling is rigid. The body and the closed impeller are made from grey cast iron. The mechanical seal does not require maintenance and is independent of the rotation direction. It is suitable for pure water of a temperature up to 140°C and water/glycol mixtures of a volume up to 40% and a maximum temperature of 40°C. Special seals and sealing materials are available for other uses.

- **Motor protection**
Integrated full overload protection by PTC thermal sensor in all stator windings.
IP 54 - Class F.

INSTALLATION

Series SIE pumps are designed for direct horizontal or vertical inline pipe mounting. The motor or module must not be mounted near the bottom. Leave a space to remove the motor, the lantern ring and the impeller. With motor powers upwards of 4kW the motor needs to be supported (mounting in vertical a duct) or a pedestal is required to support the pump body (mounting in a horizontal duct).

FEATURES

- **Packaging**
The pump, the packaging and the assembly and instruction manual are included as standard.
- **Accessories**
- Support bracket mounting
- IF module LON*

DESCRIPTION VIEW

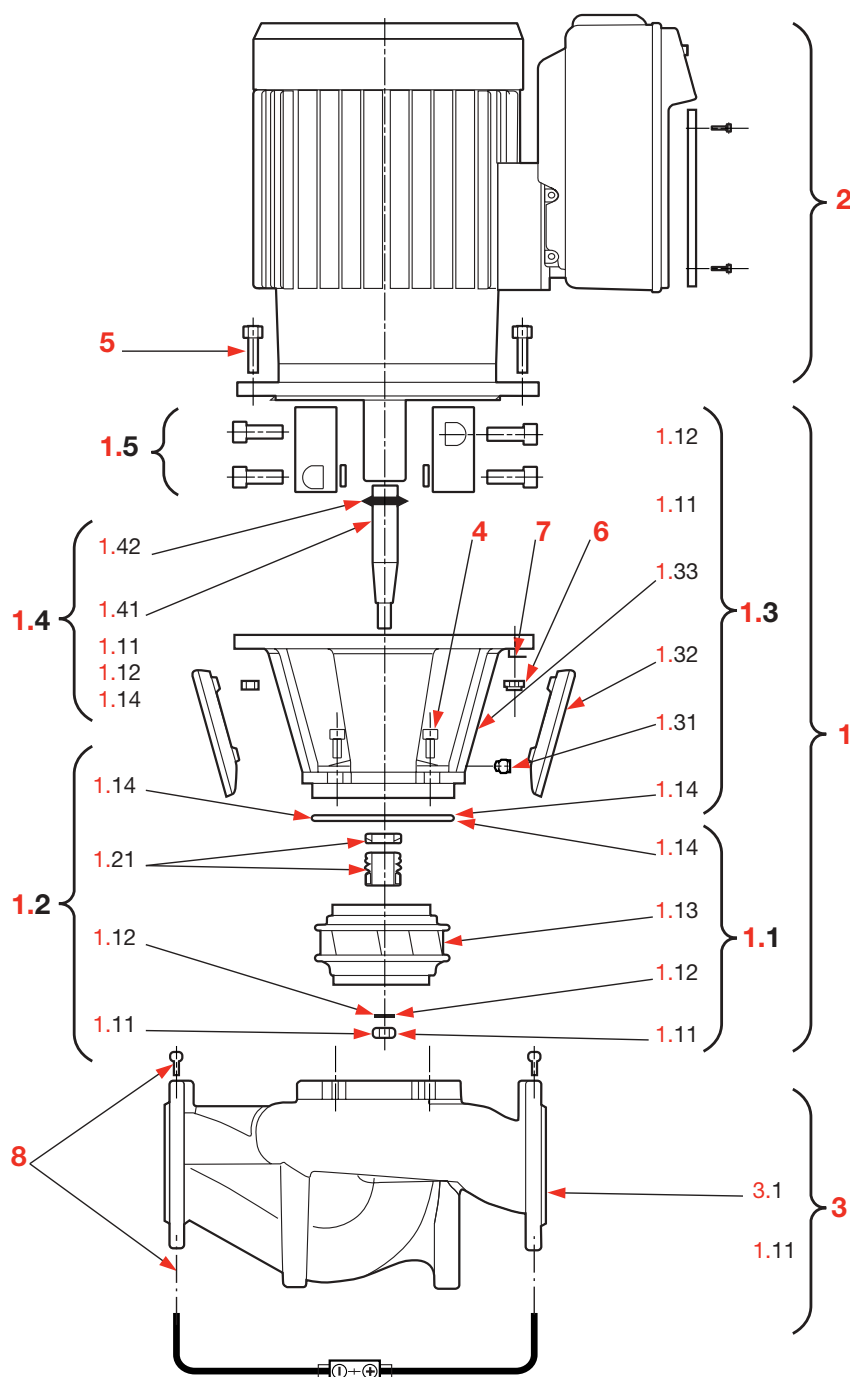

PARTS LIST

1. Complete exchange batch

- 1.1** Hydraulic kit with
 - 1.11 Nut
 - 1.12 Washer
 - 1.13 Impeller
 - 1.14 O-ring
- 1.2** Kit mechanical seal with
 - 1.21 Complete mechanical seal
- 1.3** Lantern kit parts with
 - 1.31 Bleed screw
 - 1.32 Coupling protector
 - 1.33 Lantern
- 1.4** Kit shaft with
 - 1.41 Shaft
 - 1.42 Spring stop cellar
- 1.5** Complete coupling

2. Motor

3. Complete pump casing kit with

- 3.1 Pump
 - 3.2 Stopper for pressure ports
- 4. Mounting screw for lantern/pump**
- 5. Mounting screw for motor/lantern**
- 6. Nut for motor/lantern mounting**
- 7. Washer for motor/lantern mounting**
- 8. Differential pressure sensor with pipe.**

IDENTIFICATION

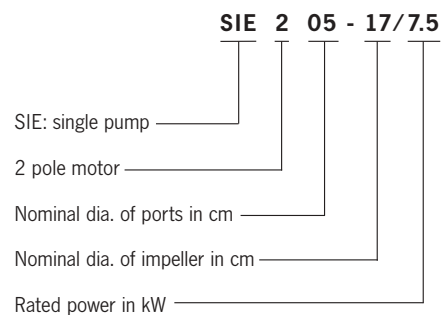

IF MODULE

Refit plug-in module for series SIE electronically controlled pumps for the following additional functions:

- Serial digital interface (only on IF module LON) for the connection to Building Management (GTC).
- DP interface for twin pump management with the functions:
 - Main/standby operation with automatic 24 h pump duty cycling,
 - Cascade mode with switching on/off of a 2nd pump at peak loads for optimised energy consumption.



WIRING DIAGRAM

Three-phase 3~400V, 50Hz/380V, 60 Hz

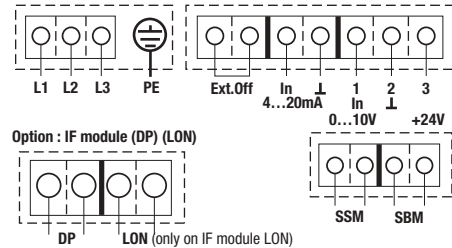

Switch rating of volt-free contacts for collective Run and Fault signals:

- min. 12 V DC/ 10 mA
- max. 250 V AC/1 A

- L1,L2,L3,PE** : Power supply 3~400V · 50 Hz – 3~380V · 60 Hz
- SSM** : Volt-free common Fault signal
- SBM** : Volt-free common Run signal
- 3** : Analog input 24 V DC for external sensor
- 2** : Ground (⊥) sensor
- 1** : Analog input (0 - 10 V) for integrated or external sensor (GTC)
- 4...20 mA** : Analog input (4-20 mA) for remote control impulse (GTC)
- Ext. Off** : Remote On/Off
- DP** : Twin pump management (2 pumps)
- LON** : Serial digital BMS interface (LONWORKS),

FUNCTIONS CHART DIE

Function	Single head pumps SIE
Mains power	
3~400V, 50 Hz	●
3~380V, 60 Hz	●
Manual function	
Pump On/Off	●
Mode selection (Δp-c, Δp-v, remote control)	●
Adjusting of the differential pressure setpoint	●
Speed selection (manual remote control)	●
Automatic function	
Infinitely variable speed control Δp-c	●
Infinitely variable speed control Δp-v	●
Full motor protection with trip function	●
Remotely controlled function	
Remote On/Off	
Command input "0...10 V" or "4-20 mA" (remote speed adjustment)	●
Signal and display function	
Collective Run signal (volt-free contacts)	●
Collective Fault signal (volt-free contacts)	●
Fault light	●
Fault code	●
LCD-screen with pump data display	●
Data exchange	
Serial digital interface (LON) for link-up to home system	● ²⁾
Double pump management (2 x single pumps)	
Normal/back up mode (automatic switching in the case of a fault/changing of pump according to time)	● ³⁾
Cascade mode (switching on/off at peak loads for optimised energy consumption)	● ³⁾

2) with 1 of IF-Module (Accessories)
3) with 2 of IF-Modules (Accessories)

GENERAL PRESELECTION GRAPHS - 2 POLE - 50Hz

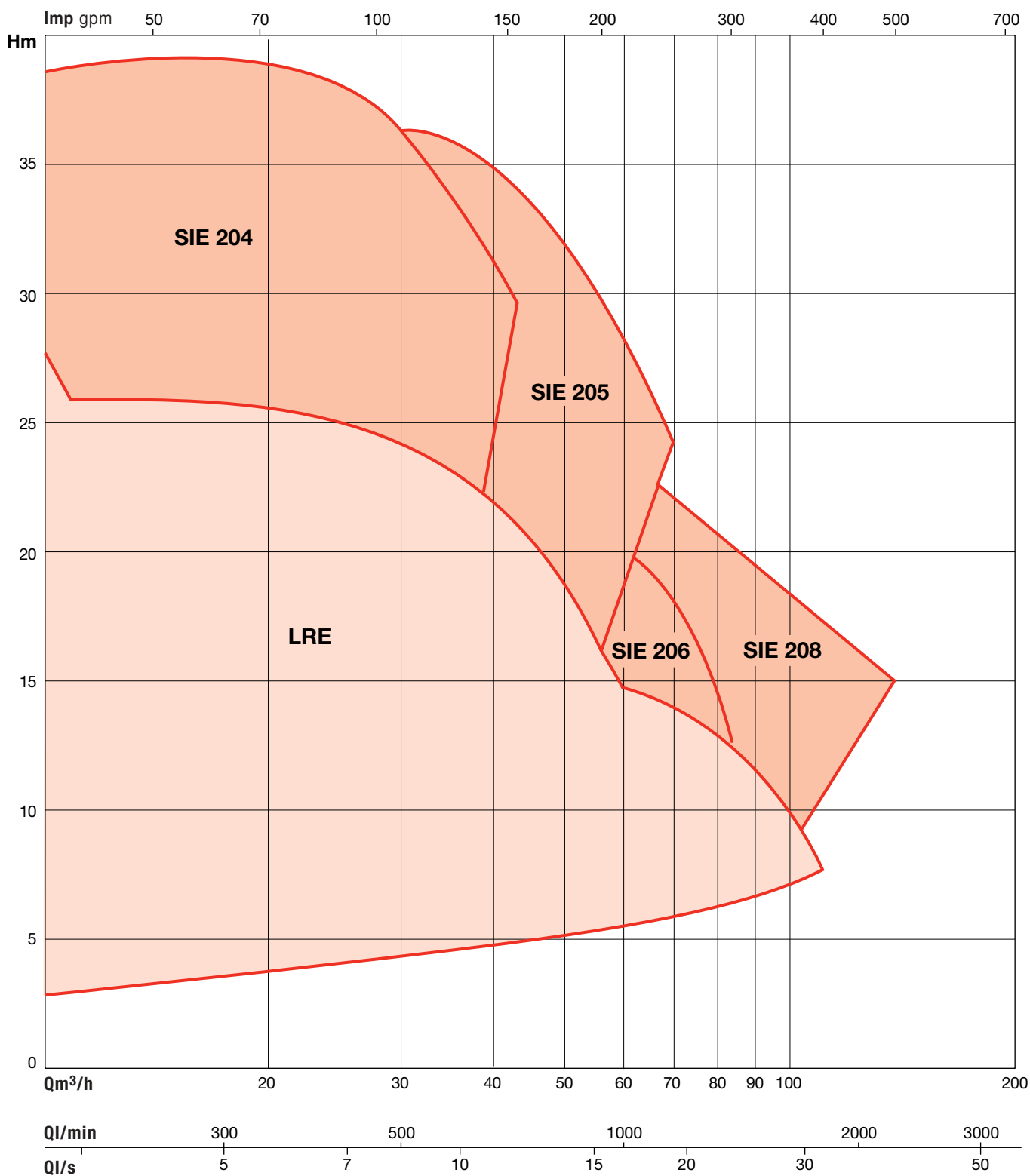

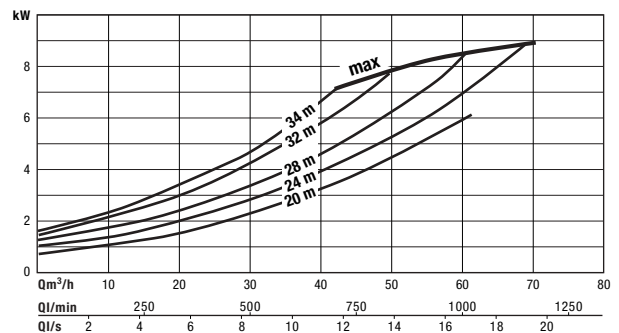
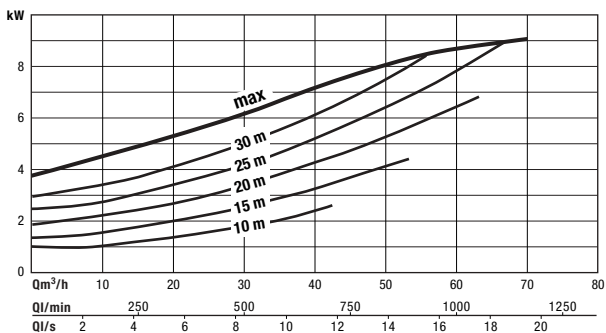
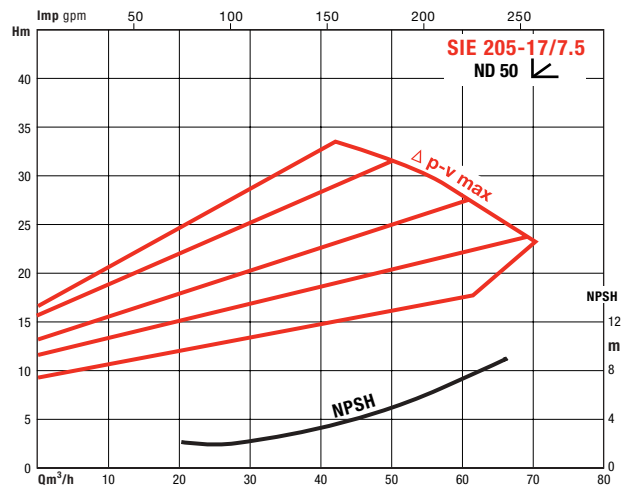
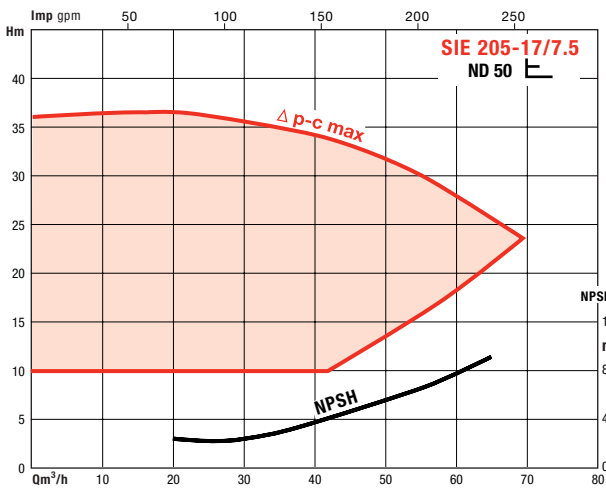
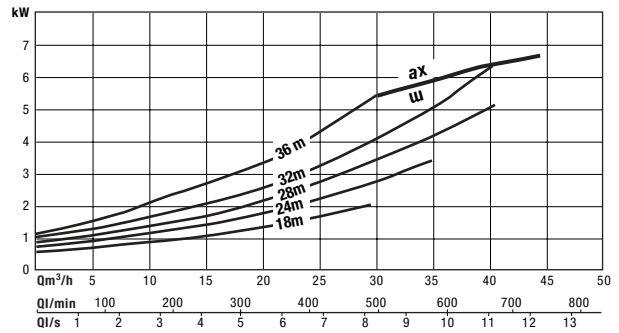
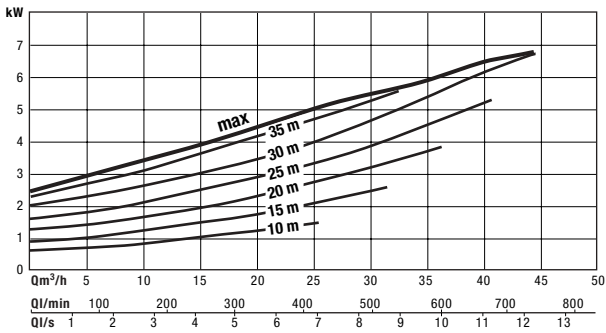
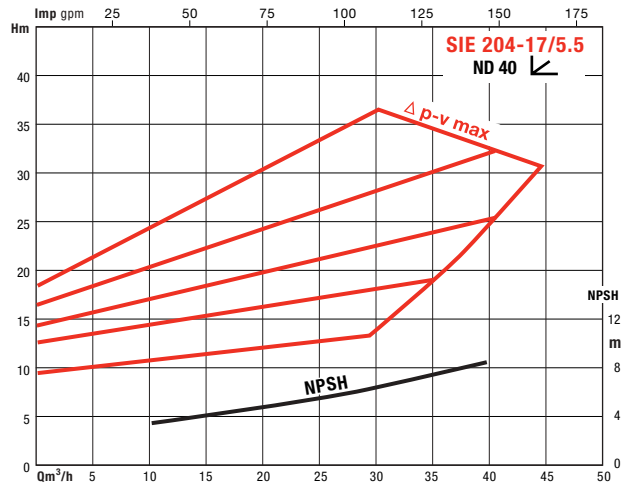
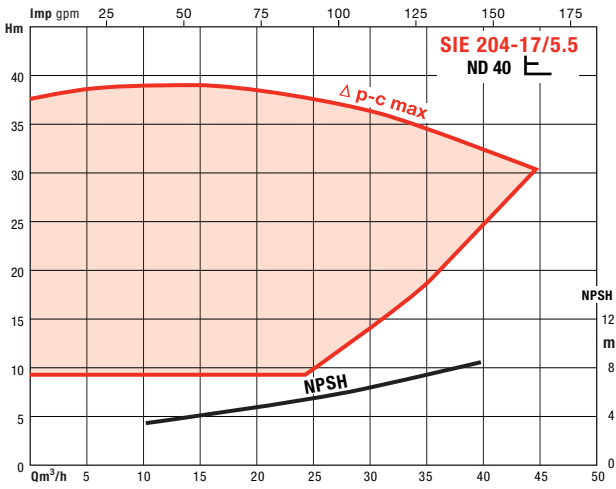

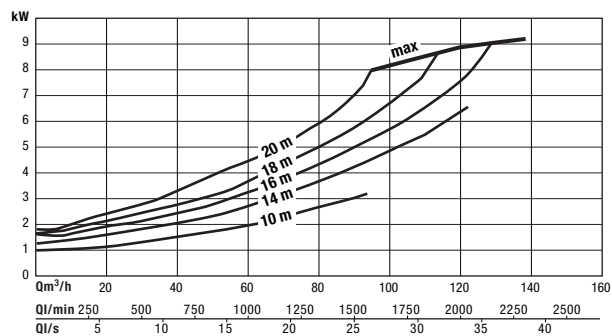
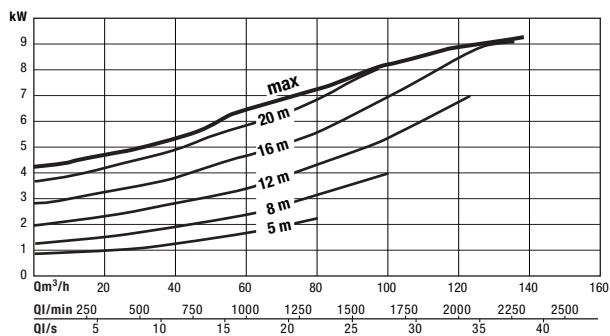
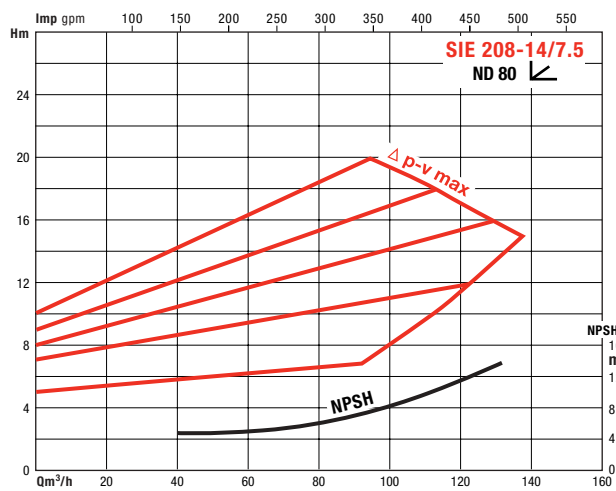
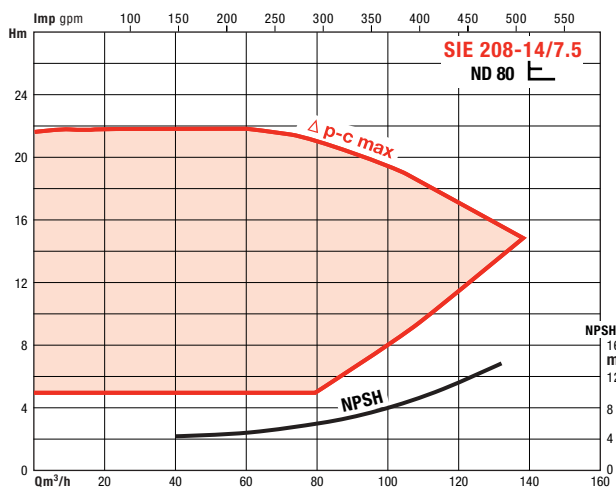
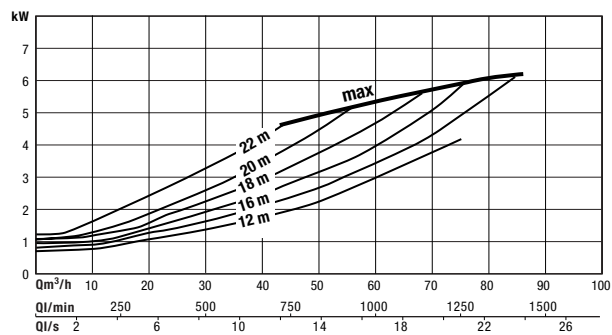
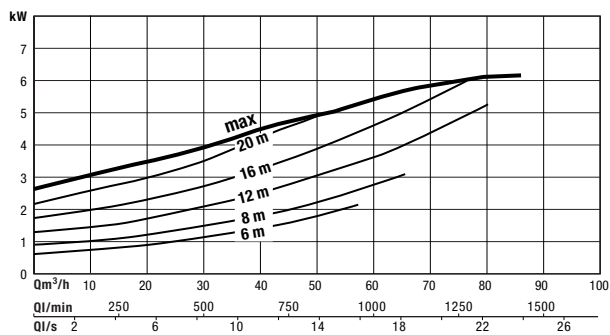
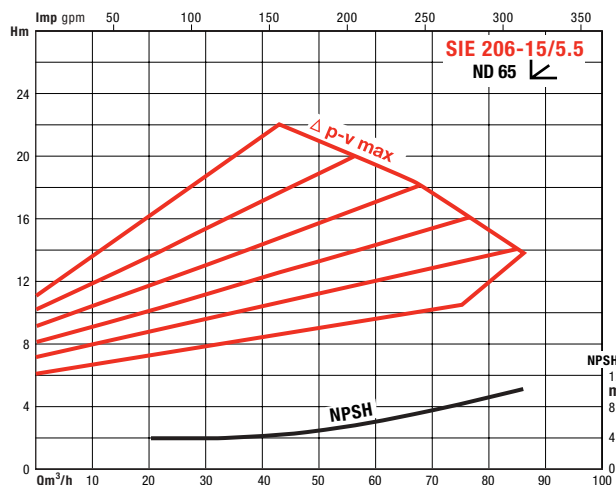
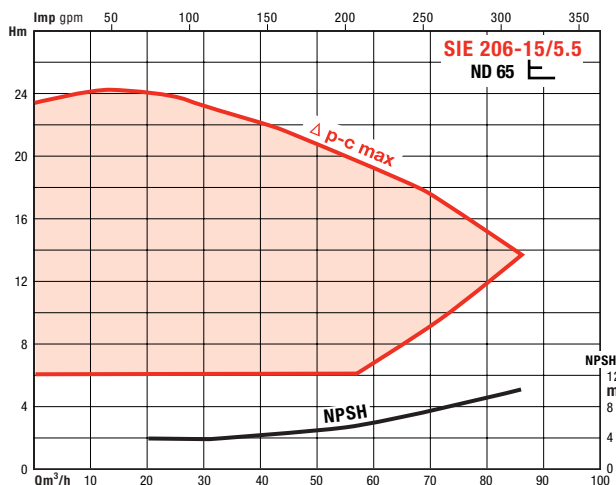

ELECTRICAL AND DIMENSIONAL CHARACTERISTICS

II : pressure G1/8
 III : venting G1/8
 * on request

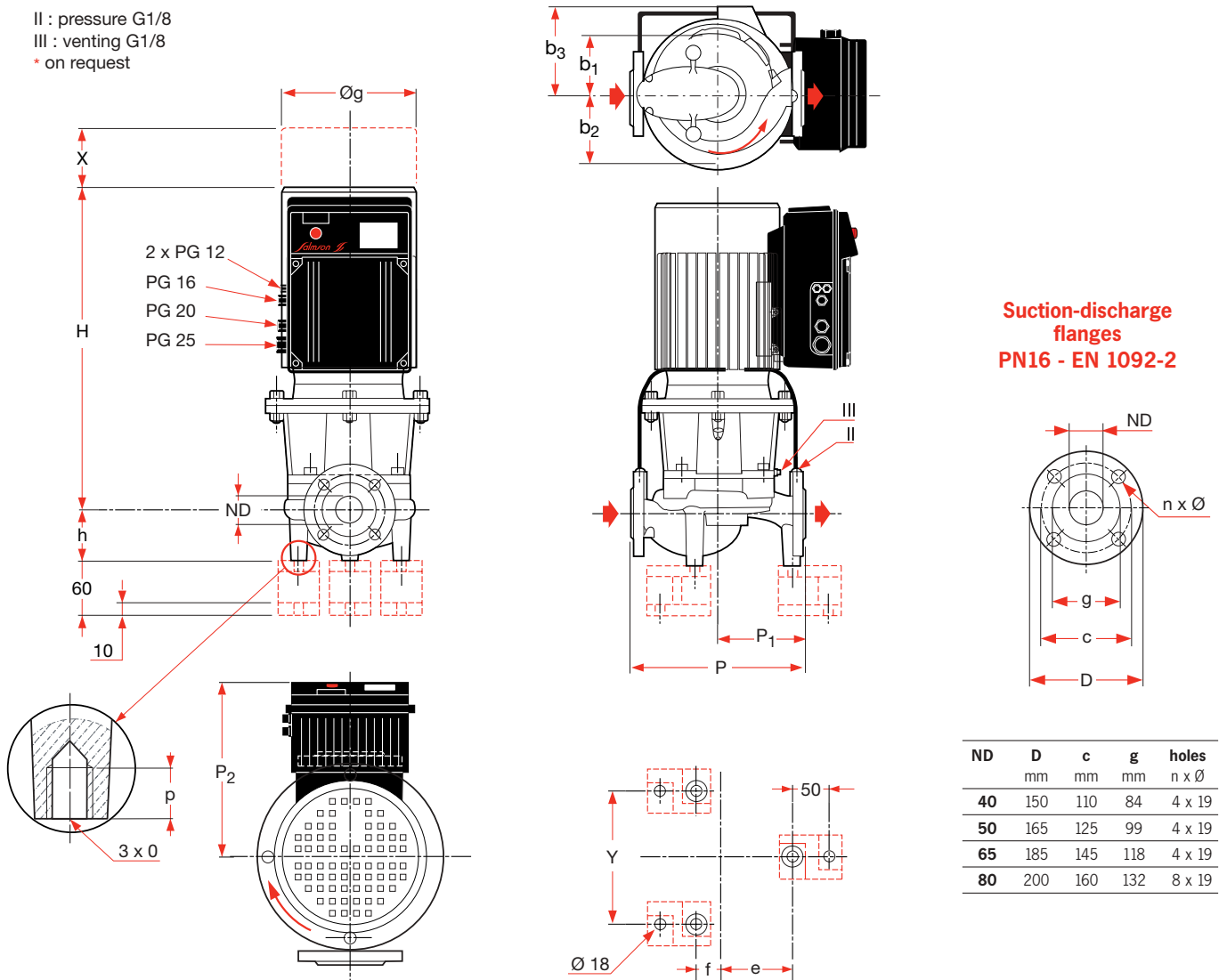

ORDER REFERENCE	MOTOR				PUMP																	
	P2	Speed	Power input	Nominal current	ND	P	h	b ₁	b ₂	b ₃	Y	e	f	Øg	H	P ₁	O	p	P ₂	X	mass	
	kW	rpm	kW	in A	mm	mm	mm	mm	mm	mm	mm	mm	mm	mm	mm	mm	mm	mm	mm	mm	mm	kg
SIE 204-17/5.5	5.5	1100-2900	7.2	11.5	40	340	82	113	129	180	130	149	58	266	583	170	M10	20	303	95	89	
SIE 205-17/7.5	7.5	1100-2900	9.3	14.5	50	340	103	120	138	180	164	143	48	266	590	170	M10	20	303	100	101	
SIE 206-15/5.5	5.5	1100-2900	7.2	11.5	65	430	110	126	146	180	180	195	60	266	596	215	M12	20	303	120	97	
SIE 208-14/7.5	7.5	1100-2900	9.3	14.5	80	400	105	123	151	180	180	173	57	266	610	200	M12	20	303	120	106	