

SCANPUMP PN 25 PUMPS BK AND NK

60 Hz

Applications

The BK pumps are used for most liquid within the pulp and paper industry, ideal for handling high temperature up to 300°C (570°F) and high pressure in digester applications. They can also be used for district heating installations.

The NK pumps are used within the process industry, specially designed to handle all kinds of clean or polluted liquids including hydrocarbons as well as aggressive chemical where PN 25 pressure rating or high temperature is required.

Design

The NK and BK pumps are part of the Scanpump Modular System ensuring high interchangeability and minimized spare part costs.

Apart from the pressure containing parts the NK and BK pumps have identical parts as the BA and NB series.

Pump casing

The sturdy construction gives good protection against erosion and corrosion. The support feet are at shaft centreline height, preventing distortion and misalignment due to expansions when pumping hot liquids.

Casing cover and lantern

The cover is retained in the casing by the lantern, both of which are therefore pressure containing parts and designed according to the PN 25 pressure rating of these pumps. The gasket is confined.

Impeller

NK pumps are normally fitted with closed (shrouded) impellers, whilst the BK pumps have semi-open impellers and casing wear discs.

The impellers are locked onto the shaft by a key and screw design, except for the smallest NK pumps (built on bearing assembly size 1) which have the impeller screwed onto the shaft, giving improved flow conditions at the impeller eye.

Shaft

The shafts are sturdy and the shaft deflection at the seal position area under normal running conditions is less than 0.05 mm (0.002 inch), promoting long shaft seal life.

Shaft seals

NK and BK pumps are fitted with Scanpump seal cartridge modules. The alternatives include single and double mechanical seals and gland packings.

Cooling

Cooling of the gland by circulating liquid is option. In addition, the bearing units are air cooled as a standard arrangement on the larger pumps by an externally mounted fan and this same arrangement can be fitted optionally on the smaller pumps, bearing assembly 3, as well.



Properties

Capacity	5-2700m ³ /h (22-12000 USgpm)
Head	5-130m (16-425 ft)
Temperature	Max. 300°C (570°F) depending on size and material
Pressure rating	PN25 (300 lbs)
Flanges	ISO 7005 PN25 ANSI class 300
Lubrication	Grease or oil
Norm	ISO 5199 technical specification for centrifugal pumps, class II

Your benefits

- **High reliability.** Sturdy design for high pressures and temperatures, rated PN25, ANSI 300. Centreline design, preventing distortion and misalignment.
- **Low power consumption.** The pumps exhibit high efficiencies - the largest size peaks 89%.
- **Simplified and fast service.** Included in the Scanpump Modular System ensuring high interchangeability and minimizes spare part costs.

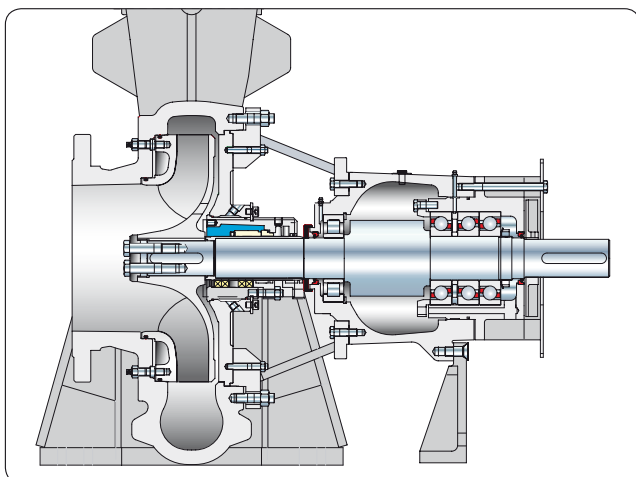

Type designations

BK 250/200-48	
BK	Pump series
250	Suction size code
200	Discharge size code
-48	Impeller size code

Performance curves

Bearing assembly sizes

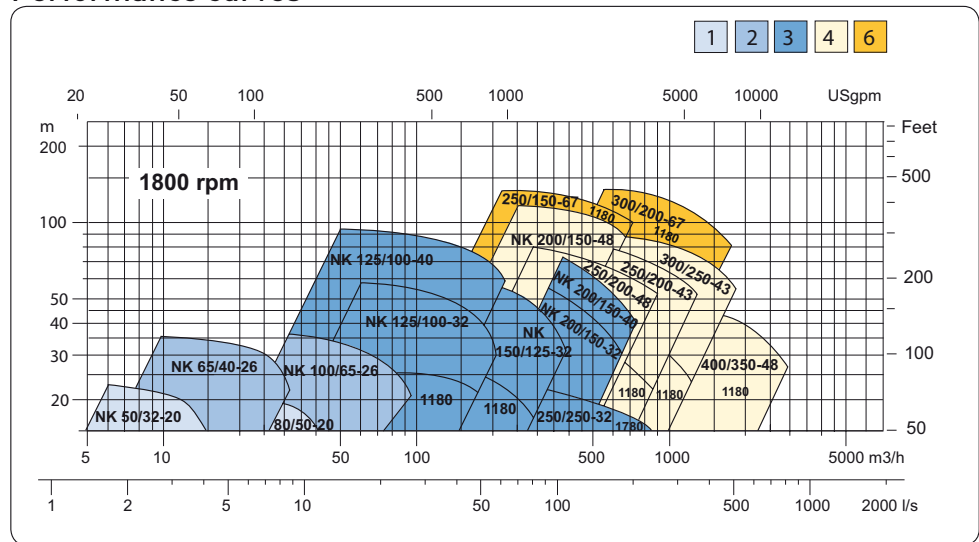

Materials

Standard material combinations	08	09	24	26
Code	08	09	24	26
Pump casing	Nodular iron	Nodular iron	Duplex stainless steel 2324	Stainless steel 2343
Casing cover	0717	0717	Duplex stainless steel 2324	Stainless steel 2343
Impeller	Duplex stainless steel 2324	Duplex stainless steel 2324	Duplex stainless steel 2324	Stainless steel 2343
Shaft	Duplex stainless steel 2324	Duplex stainless steel 2324	Duplex stainless steel 2324	Duplex stainless steel 2324
Shaft sleeve	Duplex stainless steel 2324	Duplex stainless steel 2324	Duplex stainless steel 2324	Duplex stainless steel 2324