

SCANPUMP CANTILEVER PUMP FV

50 Hz

Applications

The FV pumps are suitable for a wide range of applications, ideal to be used as sump pumps in all departments in pulp and paper mills. They are suitable for hot and waste liquids. They can also be used for sludges, slurries and liquids containing large or long solids.

Design

Cantilever design

The FV pumps have the bearings above the mounting plate - clear at all times of the sump liquid - and the shaft seal is replaced by a throttle bush around the shaft sleeve.

When properly installed, a cantilever pump will operate for many years without maintenance or repair shut-downs.

Pump casing

The pump is fixed to the support tube, which is suspended from the bearing bracket, the latter being supported by the mounting plate.

The vortex impeller ensures a clear flowpath through the casing for solids.

No shaft seal is required behind the impeller, but leakage along the shaft at this position is limited by a "throttling" volume between the shaft sleeve and a bush fitted in the casing cover.

Impeller

Vortex impellers of semi-open design are used, eliminating all clogging risks. The backvanes reduce the axial thrust. Thanks to the unique impeller design, the efficiencies of the FV pumps are higher than for other vortex pumps. The result is lower operating costs.

Shaft and bearings

There are three bearings in the rigid bearing arrangement - above the mounting plate. This means that none of the bearings are in the liquid and there is no shaft seal.

The bearing assembly contains a pair of opposed angular contact ball bearings and a roller bearing. Grease lubrication is used and the bearings are protected by an effective sealing arrangement. L10 bearing life exceeds 40,000 hours - equivalent to 5 years continuous service - calculated for the extreme recommended duty, i.e. liquid S.G 1.8 and pump speed 1800 r/min.



Properties

Capacity	3-600m ³ /h
Head	5-65 m
Temperature	Max. 220°C
Flanges	ISO 7005 PN10
Lubrication	Grease
Setting depth	Max. 2* m

*) Can be increased by 1 m by fitting an extension pipe to the inlet.



Your benefits

- **Cost-effective pumping.** The combination of the cantilever design and vortex impellers ensure trouble-free operation year in and year out.
- **Low operating costs.** Optimum impeller design creates high efficiencies, minimizing the power consumption.
- **Smart modular design.** Part of Scanpump Modular System ensures high interchangeability and less parts to service and store.
- **Minimum maintenance.** The only maintenance needed is bearing lubrication.

Type designations

FV 100/100-32	
FV	Pump series
100	Inlet dia. (mm)
100	Outlet dia. (mm)
-32	Impeller dia. (cm)

Performance curves

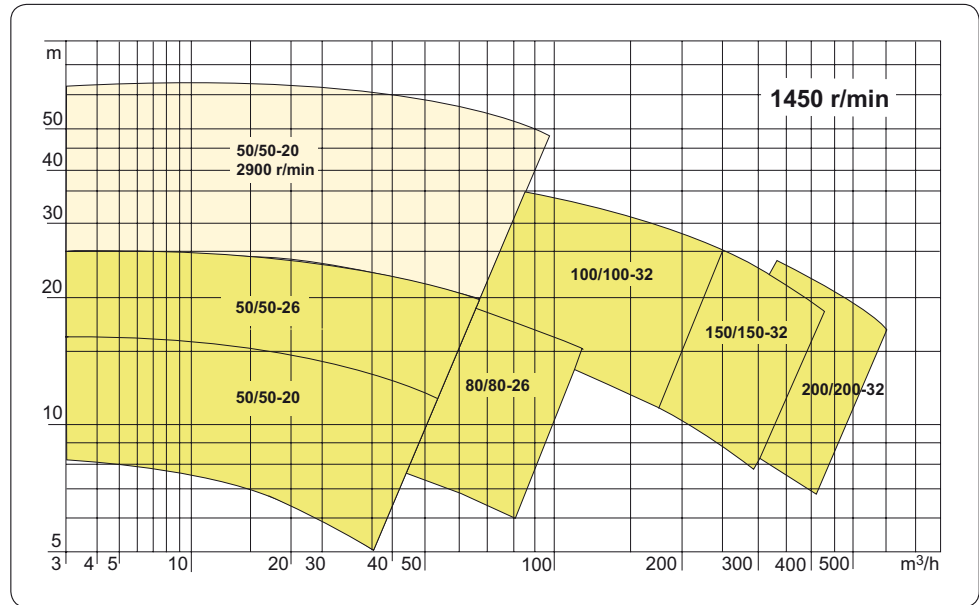

*) 50/50-20 (2900 r/min), max setting depth 1 m.

Installation

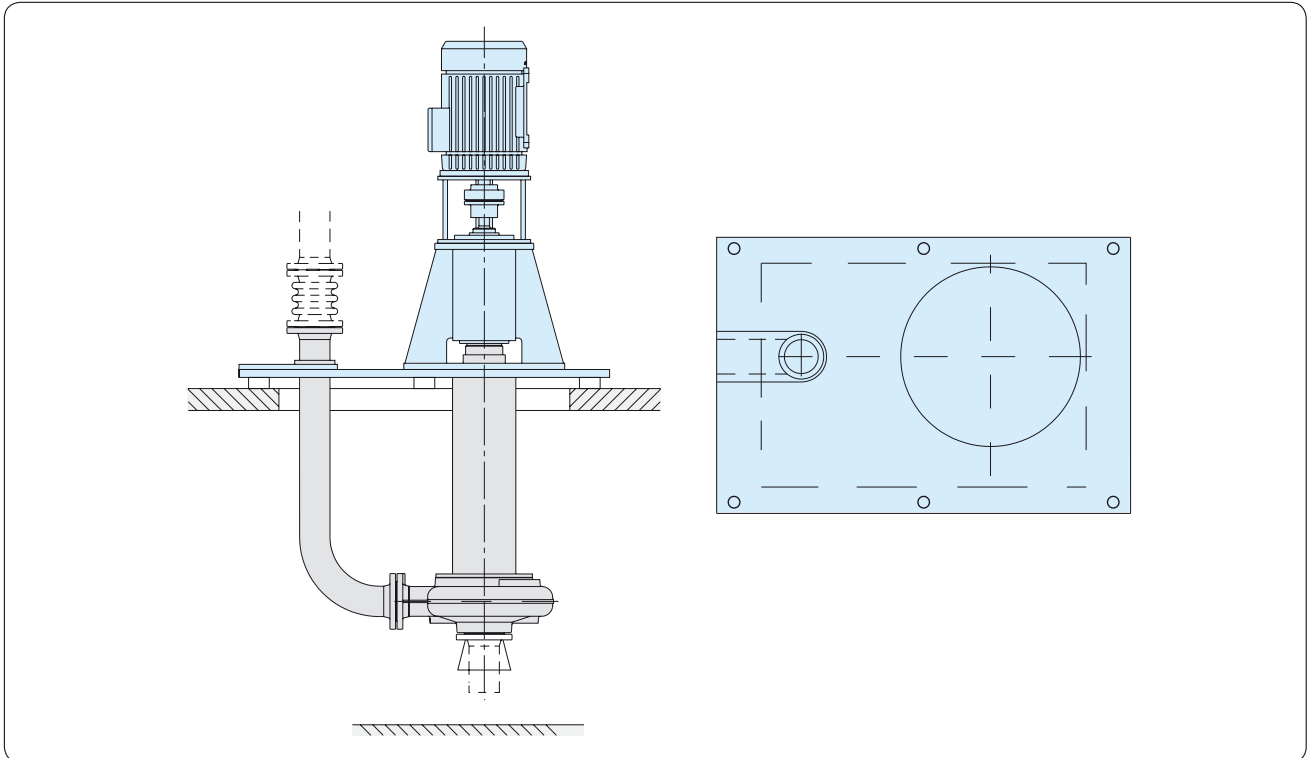

Materials

Standard material combinations		
Code	03	24
Pump casing	Cast iron 0120	Stainless steel 2324
Impeller	Stainless steel 2324*)	Stainless steel 2324
Shaft	Steel 2172	Stainless steel 2321
Shaft end sleeve	Stainless steel 2324	Stainless steel 2324

*) FV 100/100-32 and larger sizes are also available with impeller of cast iron 0120. The pumps are available in corrosion resistant alloys and the shaft is then protected by a sealed sleeve over its entire length.