

BEARING-FREE SEALLESS VERTICAL PUMPS

For Corrosive Liquid Pumping



PVDF Version



CPVC Version

DESIGN FEATURES

No Seals, No Bearings, No Wearing Parts

The ZDX/ZKX series pumps are specially designed for in-tank and out-of-tank use. They are built for heavy duty pumping of acid and alkaline solutions (pH 0-14), including electroless nickel and copper and other corrosive liquids at temperatures as high as 240°F (115°C). Rugged, corrosion resistant CPVC (to 180°F/82°C) or natural PVDF (to 240°F/115°C) construction eliminates any metal contact preventing contamination or any reaction with corrosive liquids. No bearings, seals, or wearing parts in the pump permit dry running without damage.

Patented Twin Impeller Design

Using a unique opposing twin-impeller design, the ZDX/ZKX series pumps provide high volume circulation and minimize leakage up the pump column, while minimizing entrained air.

Ease of Maintenance

The ZDX/ZKX series pumps have been designed to provide a long, reliable service life in a wide variety of industrial applications. Each phase of the pump's production cycle has been carefully controlled, thereby resulting in minimal maintenance. The only scheduled (preventative) maintenance is a periodic check of motor operational data (volts, amps) as well as the monitoring of pressure and flow rates. All pump components are readily accessible and do not require the use of any special tools.

Vibration Free

All units are delivered fully assembled and DO NOT require alignment during installation. The rigid, high strength molded pump body and corrosion resistant motors have been designed to provide quiet, vibration free operation over an extended operating pump life.

Mounts Easily

Using the convenient mounting panel included with all pumps, the pump can be easily mounted to a tank in a self-priming position, in-tank or out-of-tank, as required.

Typical Applications

- Chemical Processing
- Tank Recirculation/Transfer
- Plating
- Recirculation/Filtration
- Water/Wastewater Treatment
- Scrubber
- Parts/Spray Cleaning Booths

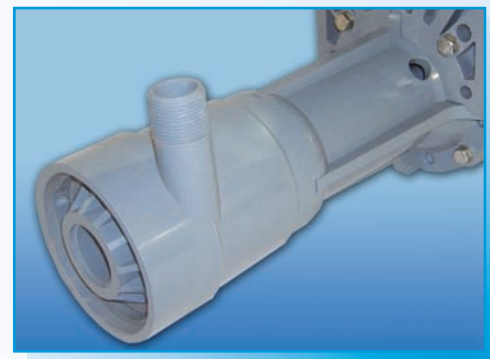
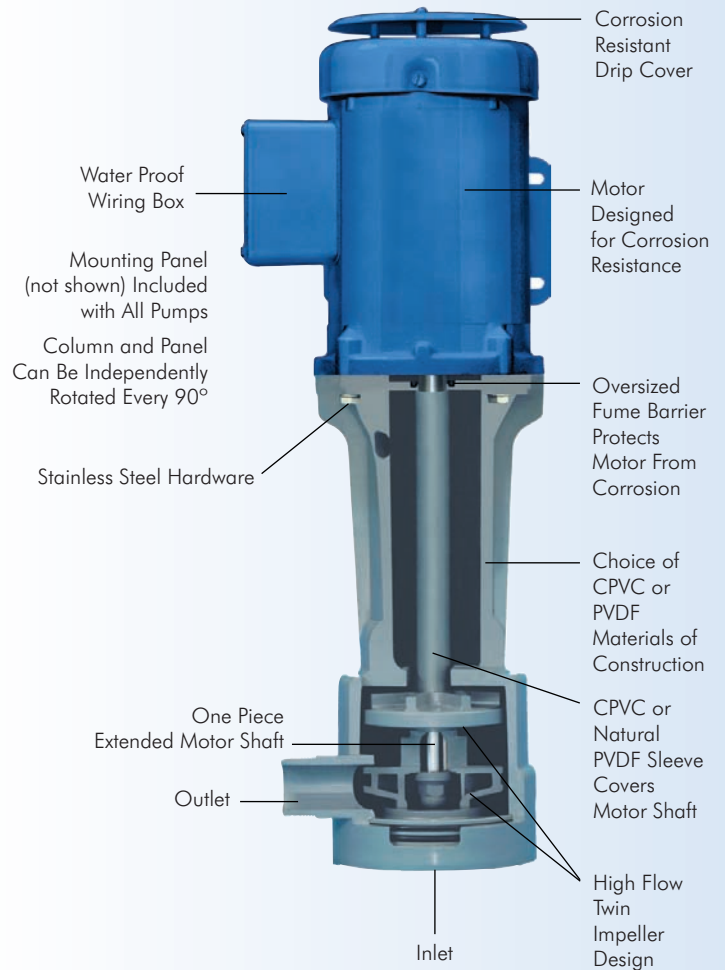

Rigid One Piece Molded Pump Body for Maximum Strength

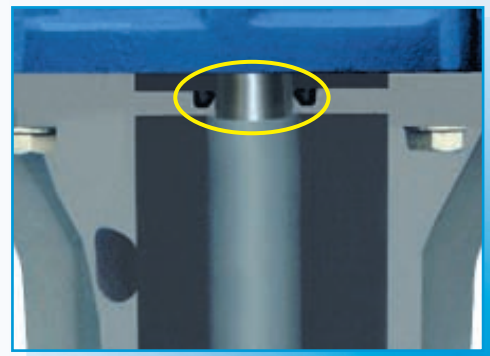

Vapor (Fume) Barrier Protects Motor From Corrosive Emissions Extending the Life of the Pump

Accessories

Suction and bottom strainers are available as optional accessories. The suction strainer is attached to the pump body and prevents larger particles from entering the pump body. A bottom strainer assembly will allow the pump to draw liquid from deep within a tank or close to the bottom of the vessel. During initial start-up and/or priming, the liquid must be above the impeller. If the pump should lose prime or the pump is stopped after the liquid level has dropped below the impeller, the liquid level must be allowed to rise above the impeller before the pump can be restarted.

OEM mounting is also available as an optional accessory. This includes a full size mounting plate (not the smaller size mounting plates normally supplied) with complete discharge piping to the top of the mounting plate, similar to the ZDX-7-1/2.



ZDX/ZKX Series Pumps Are Available With Custom Mounting Plates for OEM Applications

Motors

The ZDX/ZKX electric motors are totally enclosed, fan cooled, continuous duty rated. They are UL recognized, CSA & CE approved (except the ZDX-1/12). Each motor is equipped with a removable drip cover and corrosion resistant paint. The larger sizes, ZDX-1/3 and above, are assembled with oversized, double sealed ball bearings and have solid one-piece shafts to reduce impeller whip and provide long term reliable operation. In addition, the larger motors, ZDX-1/3 and above, are equipped with a separate lip seal where the stainless steel shaft enters the motor housing. This lip seal prevents corrosive vapor and liquids from entering the motor housing and decreasing motor reliability.

Liquid Level Control

Automatic liquid level controls are available for any ZDX pump. These controllers feature two magnetic reed switches and are prewired to turn the pump on at high level. Additional switches may be added to control additional functions, such as turning on a second pump and/or an alarm. **Consult Factory** for further details.

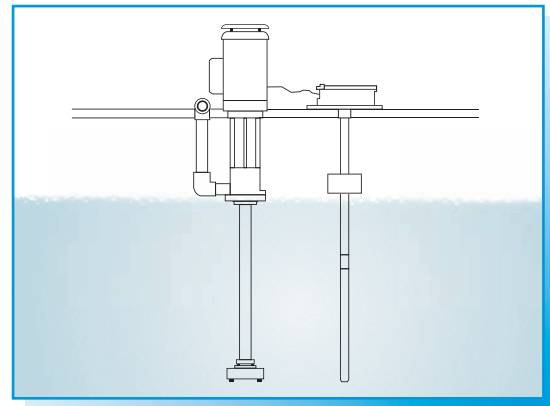

PUMP SPECIFICATIONS: FLOW CAPACITIES TO 185 GPM (700 LPM), PRESSURE TO 124 FT (37.8 METERS), 10 MODELS

Models	Mat'l of Construction	Max Flow		Max Head		Max Operating Temperature	Motor Characteristics*				Weight (lbs./Kg.)				
		GPM	LPM	Fr	M		HP	Volts	Hz	Phase	Type	Net		Packed	
											lbs.	Kg.	lbs.	Kg.	
ZDX-1/12	CPVC	10	38	10	3	180°F / 82°C	1/20	115/230	50 / 60	1	TEFC	7	3.2	9	4.11
ZDX-1/3	CPVC	18	68	18	5.5	180°F / 82°C	1/6	115/230	50 / 60	1	TEFC	21	9.5	25	11.3
ZKX-1/3	PVDF	18	68	18	5.5	240°F / 115°C	1/6	115/230 or 208 - 230/380 - 460	50 / 60	1 or 3	TEFC	21	9.5	25	11.3
ZDX-1/2	CPVC	20	75	21	6.4	180°F / 82°C	1/4	115/230 or 208 - 230/380 - 460	50 / 60	1 or 3	TEFC	23	10.4	28	12.7
ZKX-1/2	PVDF	20	75	21	6.4	240°F / 115°C	1/4	115/230 or 208 - 230/380 - 460	50 / 60	1 or 3	TEFC	23	10.4	28	12.7
ZDX-3/4	CPVC	34	129	35	10.6	180°F / 82°C	3/4	115/230 or 208 - 230/380 - 460	50 / 60	1 or 3	TEFC	44	20	52	23.6
ZKX-3/4	PVDF	34	129	35	10.6	240°F / 115°C	3/4	115/230 or 208 - 230/380 - 460	50 / 60	1 or 3	TEFC	44	20	52	23.6
ZDX-3/4HH	CPVC	41	155	47	14.3	180°F / 82°C	3/4	115/230 or 208 - 230/380 - 460	50 / 60	1 or 3	TEFC	44	20	52	23.6
ZKX-3/4HH	PVDF	41	155	47	14.3	240°F / 115°C	3/4	115/230 or 208 - 230/380 - 460	50 / 60	1 or 3	TEFC	44	20	52	23.6
ZDX-1	CPVC	76	288	48	14.6	180°F / 82°C	1	115/230 or 208 - 230/380 - 460	50 / 60	1 or 3	TEFC	45	20.4	53	24
ZKX-1	PVDF	76	288	48	14.6	240°F / 115°C	1	115/230 or 208 - 230/380 - 460	50 / 60	1 or 3	TEFC	45	20.4	53	24
ZDX-2	CPVC	94	356	64	19.5	180°F / 82°C	2	208-230/380 - 460	50 / 60	3	TEFC	45	20.4	53	24
ZKX-2	PVDF	94	356	64	19.5	240°F / 115°C	2	208-230/380 - 460	50 / 60	3	TEFC	45	20.4	53	24
ZDX-3	CPVC	105	397	81	24.7	180°F / 82°C	3	190/380 - 230/460	50 / 60	3	TEFC	62	28.1	70	31.8
ZDX-5	CPVC	140	530	109	33	180°F / 82°C	5	190/380 - 230/460	50 / 60	3	TEFC	95	43.1	105	47.6
ZDX-7-1/2	CPVC	185	700	124	37.8	165°F / 74°C	7-1/2	190/380 - 230/460	50 / 60	3	TEFC	117	53.1	13.2	60

*Single phase motors are supplied with on/off switches, cord and a manual reset thermal overload protection. 115V motors have grounded plug. All 3 phase motors must be wired by the customer with external overload protection.

SETHCO ZDX/ZKX SERIES PUMPS

ZDX-1/12 for flows to 10 GPM (38 LPM)

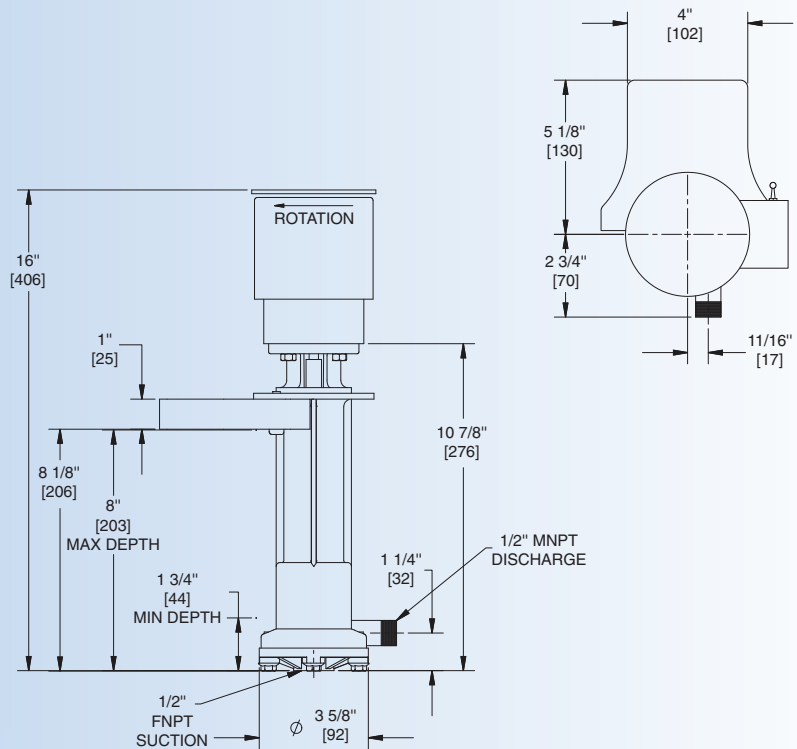

ZDX/ZKX-1/3 for flows to 16 GPM (61 LPM)

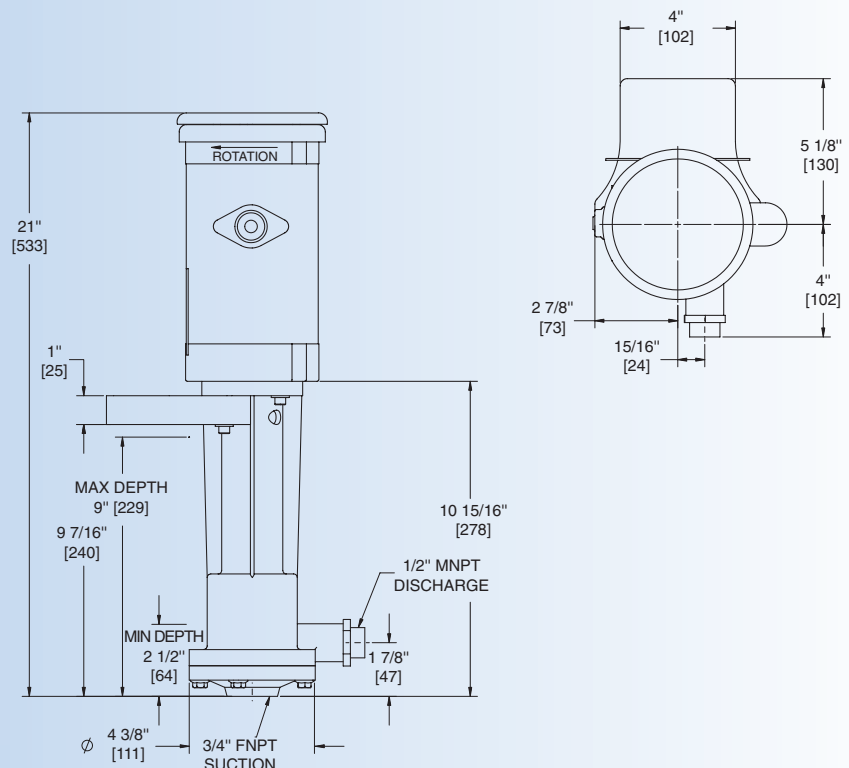

ZDX/ZKX-1/2 for flows to 20 GPM (76 LPM)

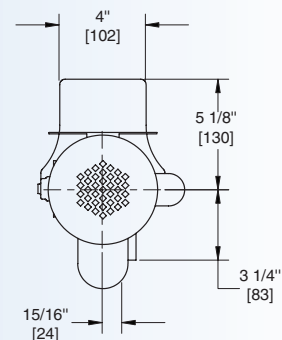
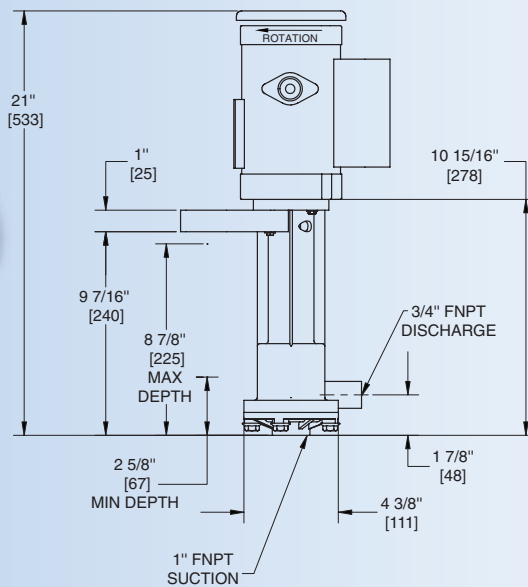

ZDX/ZKX-3/4 for flows to 34 GPM (129 LPM)

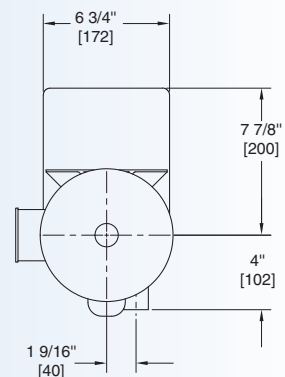
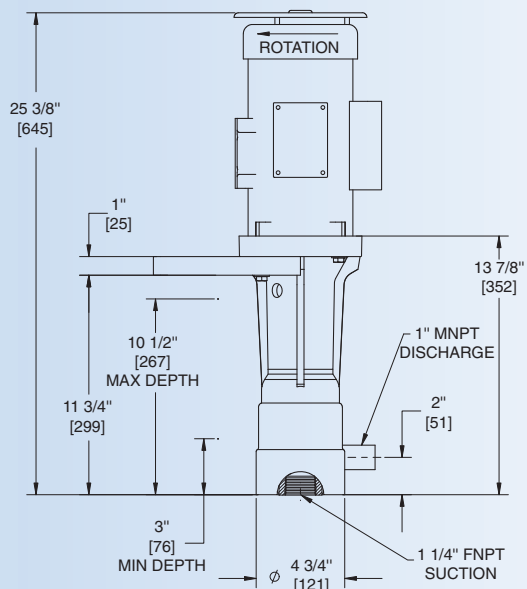

ZDX/ZKX-3/4 HH for flows to 41 GPM (155 LPM)

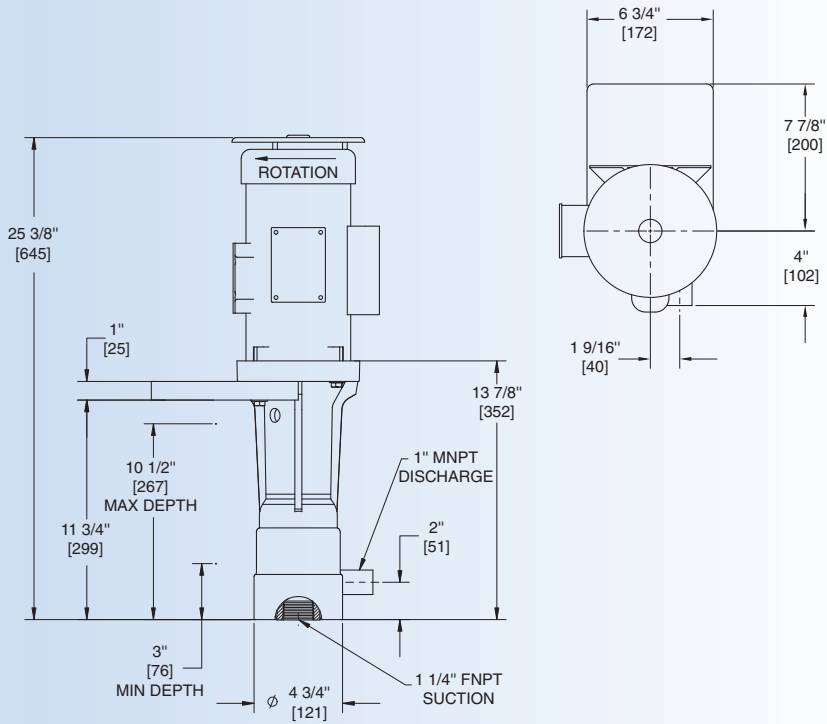

ZDX/ZKX-1 for flows to 76 GPM (288 LPM)

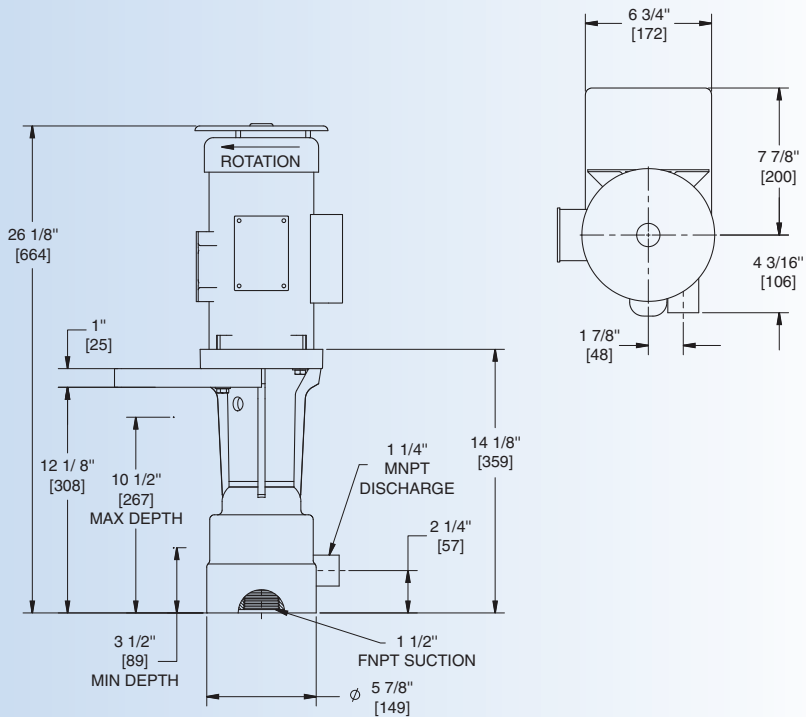
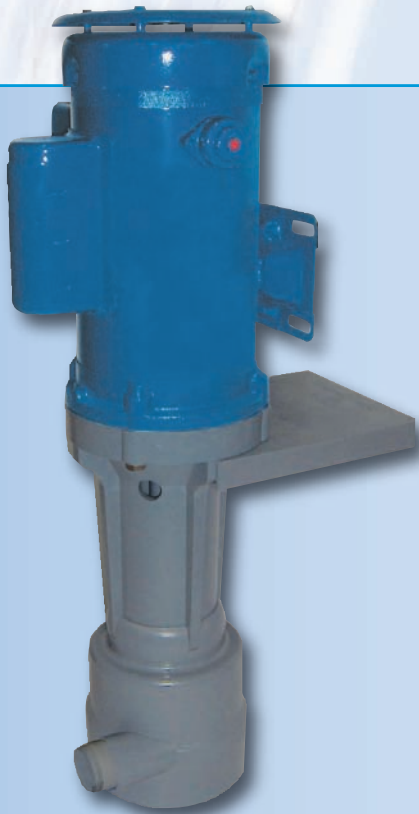

ZDX/ZKX-2 for flows to 94 GPM (356 LPM)

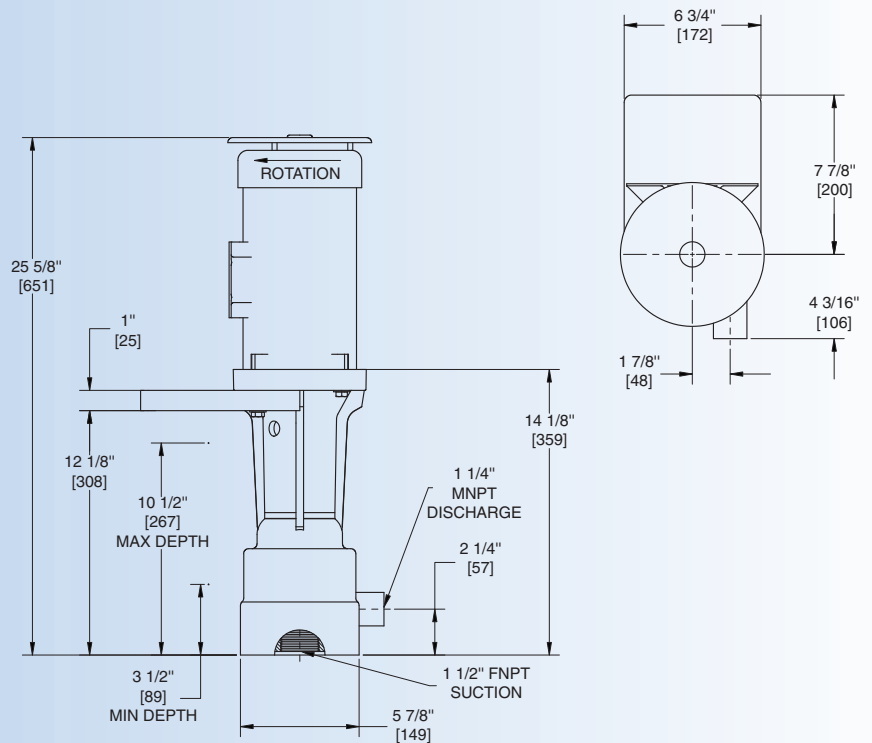

ZDX-3 for flows to 105 GPM (397 LPM)

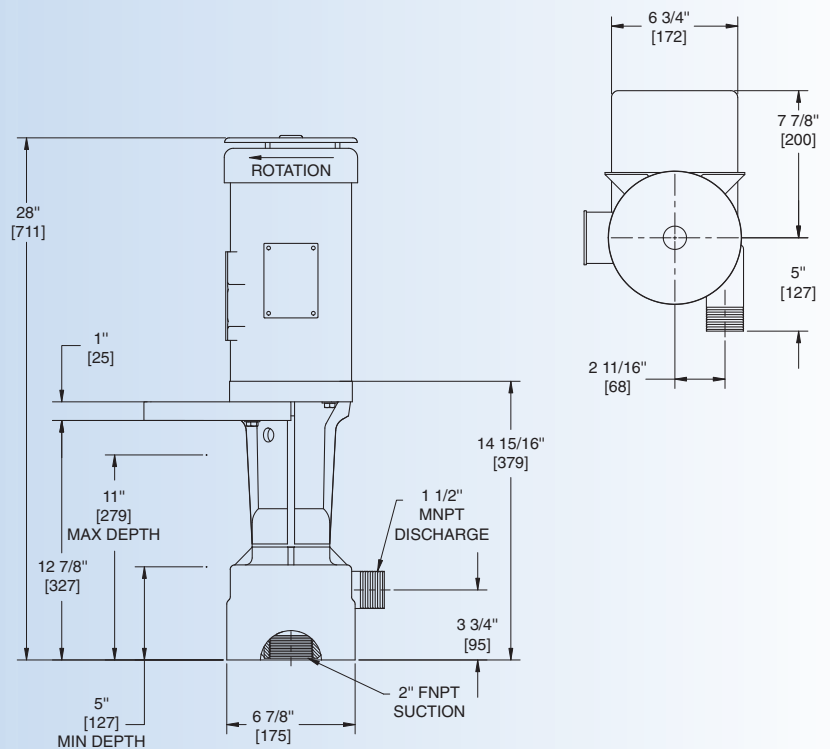

ZDX-5 for flows to 140 GPM (530 LPM)

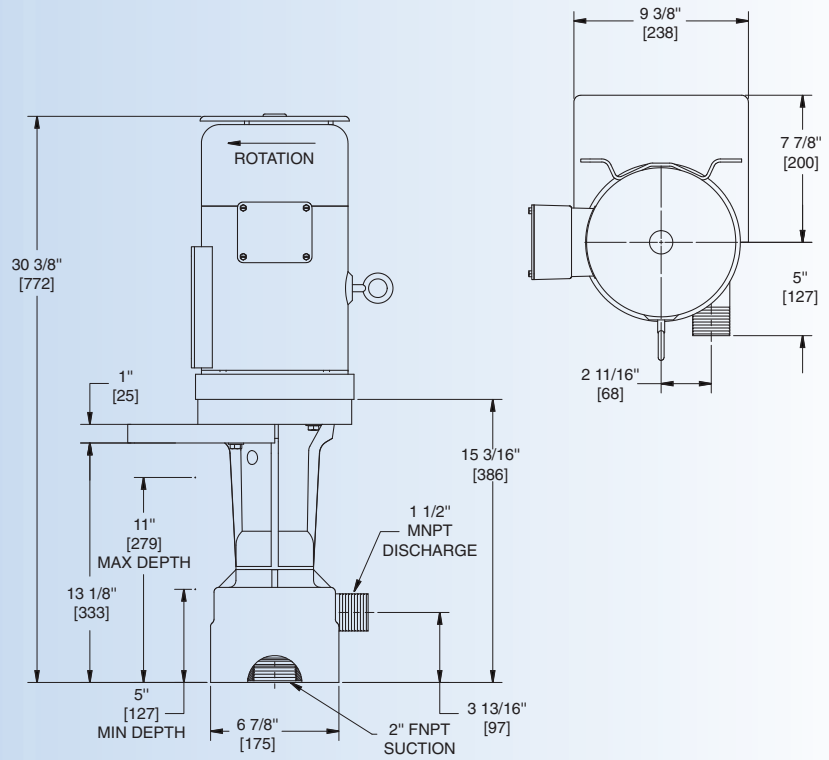

ZDX-7-1/2 for flows to 185 GPM (700 LPM)

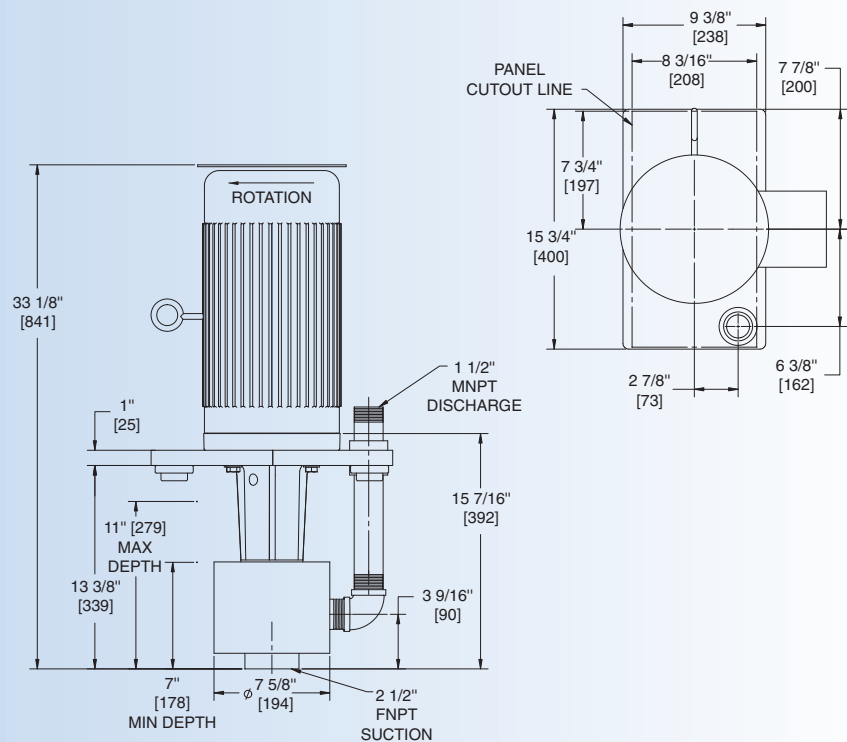

COMPOSITE CURVES

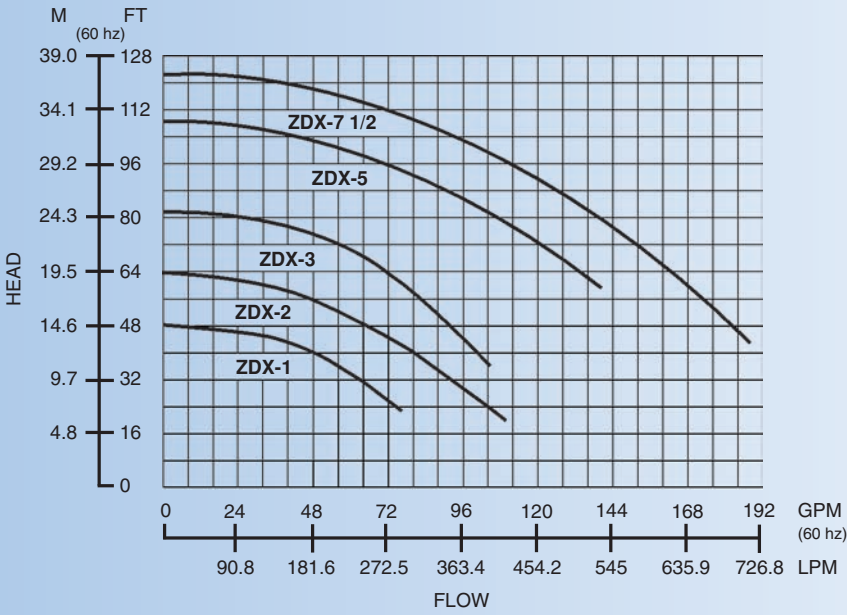

FOR MODELS

- ZDX/ZKX-1
- ZDX/ZKX-2
- ZDX-3
- ZDX-5
- ZDX-7 1/2

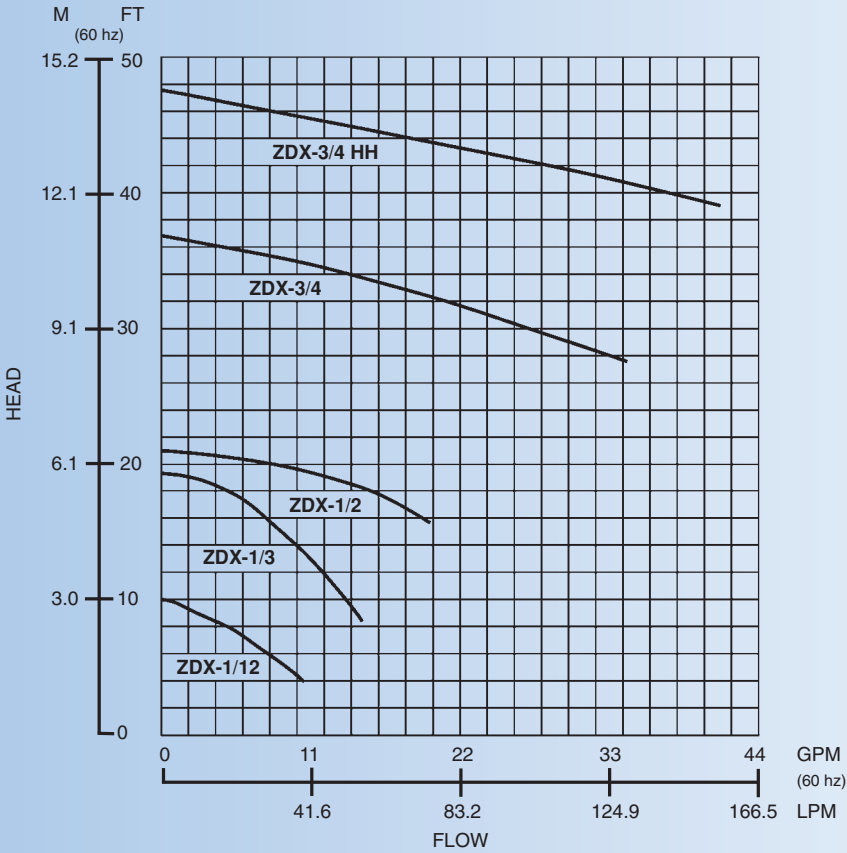

FOR MODELS

- ZDX-1/12
- ZDX/ZKX-1/3
- ZDX/ZKX-1/2
- ZDX/ZKX-3/4
- ZDX/ZKX-3/4 HH



A Met-Pro Fluid Handling Technologies Business

800 Emlen Way, Telford, PA 18969
P: 800.645.0500 • F: 215.799.0920
info@sethco.com • www.sethco.com



© 2009 MET-PRO CORPORATION, SETHCO
SETHCO® IS A REGISTERED TRADEMARK OF MET-PRO CORPORATION 909