

Please read and save this Repair Parts Manual. Read this manual and the General Operating Instructions carefully before attempting to assemble, install, operate or maintain the product described. Protect yourself and others by observing all safety information. The Safety Instructions are contained in the General Operating Instructions. Failure to comply with the safety instructions accompanying this product could result in personal injury and/or property damage! Retain instructions for future reference.

# **SHERTECH**® Bronze Plate-Mount Rotary Close-Coupled External Gear Pumps

Refer to form L-4082 for General Operating and Safety Instructions.

## **Description**

Shertech self-priming, positive displacement, external rotary gear pumps are ideal for a wide range of light-duty industrial, marine, agricultural, and commercial applications, providing a nearly pulseless flow. Close-coupled models are available directly mounted to NEMA framed AC ODP single-phase, thermally overload-protected motors or as pump heads only for custom installations. All models include a pressure relief valve. Motor-driven models are HP configured to handle up to 500 SSU at 100 PSI (specific gravity of 1.0).

Uses: For use with non-particulate and non-abrasive fluids compatible with pump wet-end construction component materials. Excellent for water-based fluids. Feature 303 stainless steel shafts, carbon graphite bushings, and Buna-N lip seal with a temperature range of -20° to 210° F. Pressure relief valve is standard. Wet-end parts are constructed from bronze, brass, stainless steel (17-7, 300 series and/or 18-8), graphite, carbon, vellumoid gasket and Buna-N.

**For more intermittent duty applications, refer to the "Carbonator Series of Rotary Gear Pumps" available in Bronze and Cast Iron.**

- Flows to 4.4 GPM.
- Max. RPM: 1725.
- Max. PSI: 100.
- Suction lift to 3.6 feet.
- Maximum viscosity of 500 SSU at 1725 RPM (max. input torque of 45 in-lbs.).
- Temperature ranges from -20 to 210° F.
- Maximum working pressure: 130 PSI.
- Pumps can operate bi-directionally (reversible). It should be noted that it is recommended that the pumps be run in the pump rotation indicated in Figure 5 (clockwise as viewed from the pump end of the pump/motor combination). In the opposite rotation, the pump is limited to 15 PSI discharge pressure, and the pressure relief valve will not function.

**NOTE:** Intermittent and heavy duty series gear pump models are also available for continued use.

**NOTE:** See Rotary Gear Pump Selection Guide in the Motor Manual for suggestions concerning installation, selection, options, and accessories.



**WARNING:** Do not use to pump flammable or explosive fluids such as gasoline, fuel oil, kerosene, etc. Do not use in flammable and/or explosive atmospheres. When pumping hazardous or dangerous materials, use only in room or area designated for that purpose. For your protection, always wear proper clothing, eye protection, etc. in case of any malfunction. For proper handling techniques and cautions, contact your chemical supplier, insurance company and local agencies (fire dept., etc.). Failure to comply with this warning could result in personal injury and/or property damage.

# SHERTECH® Bronze Plate-Mount Rotary Close-Coupled External Gear Pumps

## Model Ordering Codes and Options

Example Model: GFBV33



1st	2nd	3rd	4th	5th
Mounting	Material	Relief Valve	Gear Size: Ports	AC Motor
GF: Plate-mount Gear Pump	B: Bronze (Buna-N lip seal is standard, Viton seal is available through parts only.)	V: Pressure Relief Valve	2: 1/4" 3: 3/8"	1: 1/4 HP 2: 1/3 HP 3: 1/2 HP If blank, motor is not included with pump head.

**NOTE:** Not all order code combinations (configurations) are standard models available from the manufacturer. Custom model configurations may require ordering standard components and/or optional parts that will need to be assembled by the customer.

Manufacturer reserves the right to change model order codes, standard models, specifications, and performance without notification.

Maximum motor speed is 1725 RPM.

## Performance

Bronze Models	Port Size*	Motor HP	RPM	Max. Input Torque in.-lbs.	Suction Lift**	GPM Pumping 10 Wt. Oil at 70° F (500 SSU)					
						Free Flow GPM	20 PSI GPM	40 PSI GPM	60 PSI GPM	80 PSI GPM	100 PSI GPM
<b>Models with Motors Equipped</b>											
GFBV22	1/4	1/3	1725	45	3.2	2.2	2.1	2.1	1.7	1.5	1.3
GFBV33	3/8	1/2	1725	45	3.6	4.4	4.1	3.8	3.5	3.3	3.0
<b>Models without Motors Suggested</b>											
GFBV2	1/4	1/3***	1725	45	3.2	2.2	2.1	2.1	1.7	1.5	1.3
GFBV3	3/8	1/2***	1725	45	3.6	4.4	4.1	3.8	3.5	3.3	3.0

Test data taken on SAE 10 wt. oil at 70° F (500 SSU).

Pump performance when pump is new. As pump wears, the performance will decrease.

(\*) NPT inlet and outlet (in inches).

(\*\*) Suction lift requires wetted gears and primed seal chamber.

(\*\*\*) Motor not provided

**NOTES:** Pumps with motors are HP rated to handle up to 500 SSU at 100 PSI and specific gravity of 1.0.

Max. PSI = 100

Max. Viscosity = 500 SSU

Max. RPM = 1725

Max. Specific Gravity = 1.1 at 100 PSI, up to 1.6 at lower PSI & viscosity.

Max. Input Torque = See chart above.

Reverse Rotation = Pumps are equipped with pressure relief valves and can be run in reverse rotation; however, pressure relief valve will not function when pump is reversed unless pump relief valve cover is rotated 180 degrees. Maximum reverse pressure is 15 PSI or seal damage will occur.

The pump relationship between volume (GPM), pressure (PSI), speed (RPM) and horsepower is shown on performance chart in Shertech Motor Manual form L-4082. When pumping a more viscous liquid, a slower speed, a larger pipe size pump, and possibly a larger motor should be selected. Driver data is subject to change without notice; see label on driver for specifications and wiring information.

Manufacturer reserves the right to change performance without notification.

# Bronze Models GFBV2, GFBV3, GFBV22 and GFBV33

## Specifications

Model	NEMA Motor		AC Motor				Thermal Overload Protection		Motor Bearings	Max. RPM	PUMP CONSTRUCTION (Wet End)								Ship Wt. (lbs.)									
	Frame Required	Motor HP	Motor Voltage	Motor Amps	Motor Frame	Motor Hz	Insulation Class	Overload Protection			Duty	Port Size **	Body & Cover	Gear	Shaft	Bushings	Pressure Relief Valve****	Relief Valve Gasket		Pump Gasket	Seals ***							
<b>Models with Motors</b>																												
GFBV22	48	1/3	115	6.0	ODP	60	A	Yes†	Cont.	Sleeve	1725	1/4	BZ	BZ	303 SS	CG	BR & SS	Hard Fiber	Vellumoid	Buna Lip	20.6							
GFBV33	48	1/2	115/230	8.2/4.1	ODP	60	B	Yes†	Cont.	Ball	1725	3/8	BZ	BZ	303 SS	CG	BR & SS	Hard Fiber	Vellumoid	Buna Lip	24.8							
<b>Models without Motors</b>																												
GFBV2*	48	1/3	-	-	-	-	-	-	-	-	1725	1/4	BZ	BZ	303 SS	CG	BR & SS	Hard Fiber	Vellumoid	Buna Lip	4.6							
GFBV3*	48	1/2	-	-	-	-	-	-	-	-	1725	3/8	BZ	BZ	303 SS	CG	BR & SS	Hard Fiber	Vellumoid	Buna Lip	4.8							

BZ = Bronze BR = Brass SS = Stainless Steel CG = Carbon Graphite ODP = Open Drip-Proof

(\*) Motor not provided, but suggested. Pump head only provides the ability to adjust HP for viscosity and to use existing and/or special motors. (\*\* NPT inlet and outlet (in inches).

(\*\*\*) Lip seal components include 303 stainless steel case and garter spring.

(\*\*\*\*) Models are made of stainless steel (17-7, 300 series and/or 18-8), brass and/or bronze.

(†) Thermal overload protection reset may be automatic or manual.

**NOTES:** Motor may be split-phase or capacitor start.

Motor base may be removable, movable or fixed.

Driver data is subject to change without notice; see label on driver for specifications and wiring information.

Manufacturer reserves the right to change specifications without notification.

## Dimensions

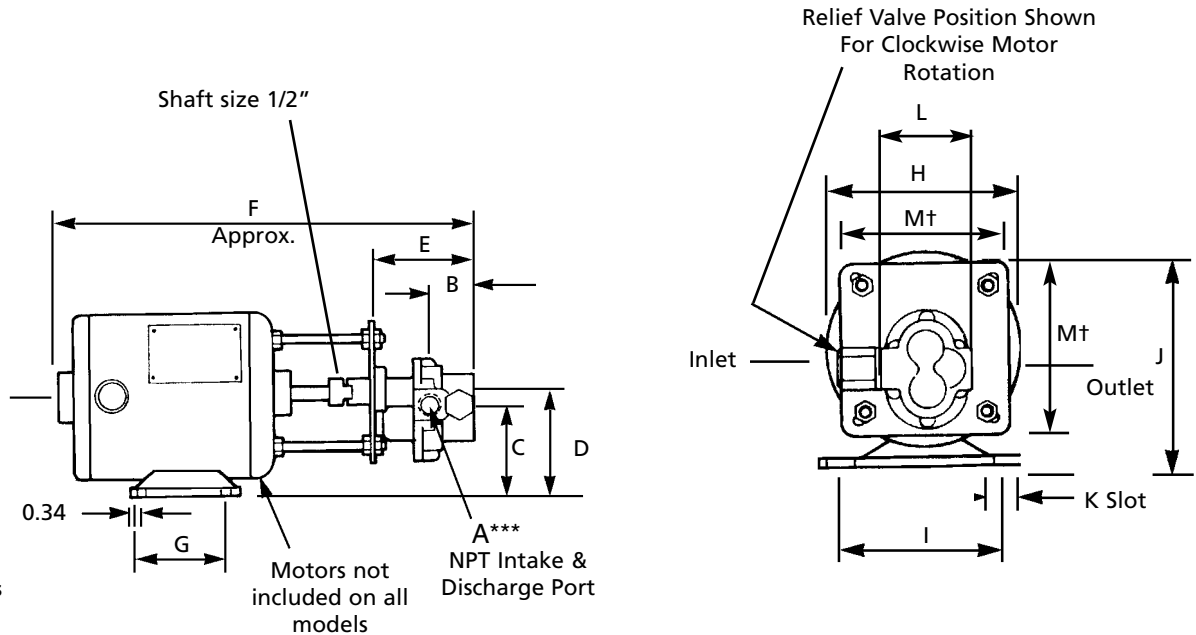

Figure 1 - Dimensions

## Pumps with NEMA 48 Frame Motor

Models	A***	B**	C**	D**	E	F**	G**	H**	I**	J**	K**	L	M(†)
GFBV2* & GFBV22	1/4	.47	2.44	3.00	2.88	14.06	2.75	5.69	4.25	5.75	1.06	2.50	4.875
GFBV3* & GFBV33	3/8	1.53	2.44	3.00	3.31	15.00	2.75	5.69	4.25	5.75	1.06	2.50	4.875

(\*) Motor not supplied, head only. Dimensions are typical when mounted to 48 frame motors.

(\*\*) This dimension may vary due to motor manufacturer's specifications.

(\*\*\*) NPT inlet and outlet (in inches).

(†) Accommodates motor bolt circles of 5.13 to 5.83 and hole diameter of .34".

**NOTE:** Dimensions have a tolerance of (+ or -) 1/8".

Manufacturer reserves the right to change dimensions without notification.

# SHERTECH® Bronze Plate-Mount Rotary Close-Coupled External Gear Pumps

**⚠ WARNING** Check motor. It may be equipped with an automatic resetting thermal protector and may restart unexpectedly (see specifications chart). Protector tripping is an indication of motor overloading as a result of operating the pump at too high a pressure (over 100 PSI), too high of viscosity, too high of specific gravity, excessively high or low voltage, inadequate wiring, incorrect motor connections, too small a motor (sized incorrectly, not enough HP), or a defective motor or pump.

Do not handle pump with wet hands or when standing in water. Failure to follow the General Safety Information and all warnings could result in fatal electrical shock!

## Assembly (If pump and motor are pre-assembled, skip assembly.)

The pump is supplied already mounted to an adapter bracket and ready for attaching to your motor. The necessary mounting equipment is packaged separately with pump, and contains (See Figure 8):

- Drive coupling half for motor shaft (Ref. No. 19).
- Flexible coupling insert (Ref. No. 19).
- Four (4) mounting bolts (Ref. No. 18).
- Twelve (12) nuts (Ref. No. 17).

To assemble the pump to a motor:

- Remove the four (4) thru-bolt nuts from your motor (See Figure 3).
- Select threaded end of mounting bolts which matches your motor threaded thru-bolt. Note the bolt is internally threaded size 8 thread at one end and size 10 thread at the other (See Figure 2). Attach four (4) nuts (Ref. No. 17) to mounting bolts at end that mounts to motor thru-bolts. Install mounting bolts in motor thru-bolts. Tighten four (4) nuts against motor frame (See Figure 3).

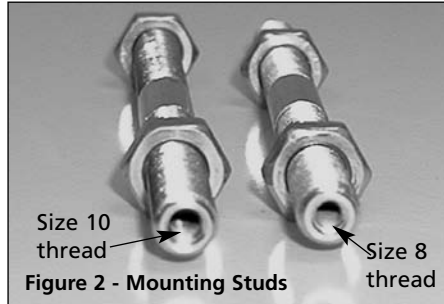

- After mounting bolts are secured, rotate motor shaft by hand to make sure there is no bind. If bind occurs, adjust thru-bolts accordingly to assure free rotation (See Figure 3).

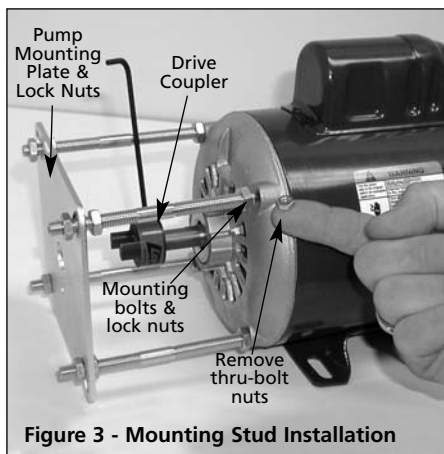

- Slip coupling half (Ref. No. 19) onto motor shaft end and tighten set screw. Insert flexible insert. (Ref. No. 19 and Figure 3).
- Thread a jam nut on each of four (4) mounting bolts an equal distance from stud end (See Figure 3).
- Place pump and bracket assembly onto the four (4) mounting bolts and position it so that 1/16" free play exists off end face of the flexible member of drive coupling (See Figure 4).

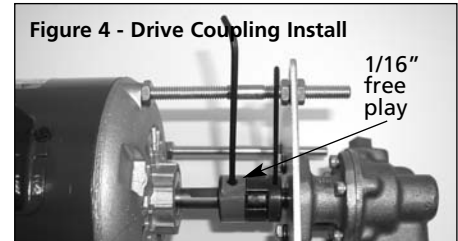

- Bring jam nuts that are on mounting bolts into position against pump bracket to secure this position. At this point, all nuts should be equal distance from end of mounting bolts.
- Finally, check pump alignment. The pump bracket should be square with motor shaft. The coupling halves should be matched and parallel with shaft. The flexible coupling member should be free to slide back and forth in its clearance. The pump should turn freely by hand.
- Rotation: When facing the motor shaft end, proper motor pump rotation is clockwise (CW). Flow is left to right (See Figure 5). Standard pumps have pressure relief valves.

**⚠ CAUTION** Failure to follow correct shaft rotation, or mounting pressure relief valve incorrectly on pump, can result in seal failure.

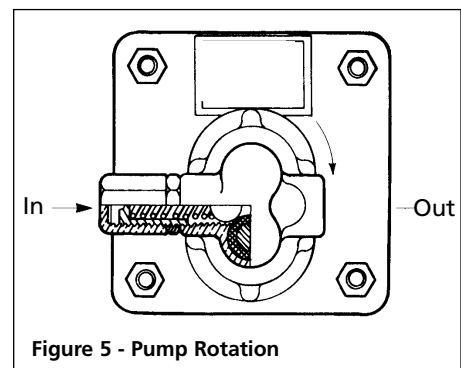

- Motor should be securely fastened to a rigid surface, preferably metallic. For rigidity, use largest bolts that will fit through base holes.

## Bronze Models GFBV2, GFBV3, GFBV22 and GFBV33

### Installation

**IMPORTANT:** In any installations where property damage and/or personal injury might result from an inoperative or leaking pump due to power outages, discharge line blockages, or any other reason, a backup system(s) and/or warning system(s) should be used.

In order to safely use this product, familiarize yourself with this pump and also with the liquid (chemical, etc.) that is going to be pumped through the unit. This pump is not suitable for many liquids.

1. Open drip-proof motors are designed to be used in clean, dry locations with access to an adequate supply of cooling air.

**CAUTION** Ambient temperature around motor should not exceed 104°F (40°C).

*Do not put excessive loads on pump by tightening suction and discharge lines without proper support. Misalignment of pump housing and coupling could result in pump failure.*

2. For outdoor installations, motor must be protected by a cover that does not block air flow to and around motor.

**NOTE:** Pump misalignment is the greatest cause of gear and bearing wear and must be avoided. Many pump mountings act as noise amplifiers. A rubber pad under the pump base will help reduce the noise level.

3. For hazardous locations (explosive atmosphere), an explosion-proof motor is required; consult your local governmental inspection agency or insurance company for guidance.
4. Locate pump as close to liquid source as possible.
5. Attach suction line to suction inlet.
6. Avoid excessive lengths or number of fittings and bends in suction line.

7. It is recommended that same size pipe as pump ports be used, or in cases requiring suction piping greater than 6 ft., the next larger size pipe should be used.

**NOTE:** Should the pump need to be self-draining, the pump head should be mounted in the vertical position with the suction port facing down. When pumping high viscosity oils, the vertical position can be used with the suction port facing up and the pump mounted under the source. Increasing the suction pipe size and eliminating bends and elbows also assists in pumping high viscosity fluids.

8. If suction lift is greater than what is indicated in the performance chart, attach a foot valve below liquid level at end of suction line to ensure positive priming. Also note: If fluid specific gravity is greater than 1.4 or viscosity greater than 500 SSU, a foot valve is also recommended.
9. If solid contaminants are suspected in liquid, place a filter in suction line.
10. Be certain all suction piping connections are air tight.
11. Attach discharge piping to discharge outlet.

**WARNING** Support pump and piping when assembling and during installation. Failure to do so may cause piping to break, pump to fail, motor bearing failures, etc., all of which can result in property damage and/or personal injury.

*Shutting off discharge without providing pressure relief can cause extreme over-pressure, which can result in pump and/or motor failure.*

*An incorrect connection may cause an electric short, produce an electrical shock or burn out the pump motor, resulting in property damage and/or personal injury.*

12. All pumps are provided with a pressure relief valve to allow the use of a shut-off valve or hand

gun. Valves are set from the factory at 25-50 psi and may have to be adjusted up to 100 psi. Internally-relieved pumps should not be run fully relieved for periods longer than one minute, and an optional external pressure relief valve is required.

**NOTE:** Globe valve or other restrictive valves should not be used as shut-off mechanism as they are restrictive in nature and will seriously affect pump performance.

### Operation

1. All pumps must be primed before start-up. Care should be taken at all times to avoid running dry as this will cause rapid wear of the gears, seal, and bearings, reducing pump performance and shortening pump life. Never operate pump unless it is secured to solid foundation.
2. Gear pumps are built to very close tolerances and this tolerance must not be altered. The liquids must, therefore, be free of all abrasives. Sand, silt, wettable powders, etc. must be avoided.
3. The pump relationship between volume (GPM), pressure (PSI), speed (RPM) and horsepower is shown on performance chart up to 500 SSU at 100 psi (specific gravity of 1.0). When pumping a more viscous liquid, a slower speed, a larger pipe size pump, and possibly a larger motor should be selected.
4. Re-check motor rotation. Proper motor/pump rotation is clockwise (CW) when facing the motor shaft.
5. To change the location of the ports and keep the same rotation, rotate the pump and plate 180°. If pump motor does not rotate CW when looking at its shaft, then change motor connections to reverse

# SHERTECH® Bronze Plate-Mount Rotary Close-Coupled External Gear Pumps

## Operation (Continued)

rotation. The pressure relief valve must always be on the inlet port side. If the pump pressure relief valve cover is removed, it must be reassembled in the same orientation as it came from the factory. When viewing the cover side of the pump, the pressure relief valve will be on the left side when the pump is mounted with the idler shaft pocket down. (This is the portion of the pump without the shaft.)

- Standard pump models are equipped with pressure relief valve. The inlet port is always on relief valve side.
- Pressure Relief Valve: Standard models are supplied with a built-in pressure relief valve. The valve may be adjusted and used to set system operating pressure or used as a system pressure relief valve to prevent pump and motor damage that occur when discharge line is closed off. However, this is not a full-line pressure relief valve, and in cases where frequent extended pressure relief valve operation is anticipated, an external discharge line connected either, back to the tank, or well downstream from the pump suction inlet is recommended. This pressure relief valve is not factory set. Extended operation (over one minute) under shut-off conditions could cause pump to overheat, leak and damage itself.

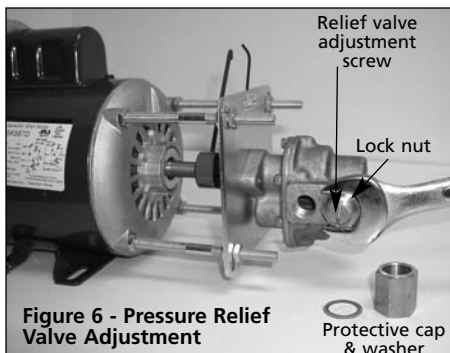

Figure 6 - Pressure Relief Valve Adjustment

- To increase the pressure relief valve pressure setting, remove pressure relief valve stem cap cover and turn the adjusting valve stem (Ref. No. 4) in (clockwise). Turning the adjusting valve stem out (counterclockwise) will reduce the pressure setting (See Figure 6).

## Maintenance

**⚠ WARNING** *Make certain that the power supply is disconnected before attempting to service or disassemble any components!*

*If the power disconnect point is out of sight, lock in the open position and tag to prevent unexpected application of power. If the power disconnect point is out of sight, lock in the open position and tag to prevent unexpected application of power.*

## GENERAL

Pump should be checked for proper operation daily, weekly, monthly, etc. If anything has changed (pump noise, motor noise, leaks, etc.) since the pump was new, the pump should be removed, examined and repaired if necessary. This is a difficult motor/pump to repair, therefore, only a qualified electrician or service technician should attempt to repair this unit. Improper repair and/or assembly can cause problems with the electric motor used with this unit. See General Safety Information.

Rotary gear pumps must be drained completely if they are used in an area subject to freezing temperature.

If the pump is to be stored, place a small quantity of light oil or some other storage preservative compatible with your application in the pump and rotate the shaft very slowly to work the oil throughout the gears and the body.

## DISASSEMBLY AND ASSEMBLY

Refer to Figure 8 for disassembly and assembly procedures.

- Remove screws (Ref. No. 8), lockwashers (Ref. No. 9), and cover (Ref. No. 13).

- Shafts (Ref. Nos. 10 and 11) can be removed.
- For replacement only, pry out lip seal (Ref. No. 13) and replace seal with garter spring towards inside or body of pump (See Figure 7).

**NOTE:** Pump drive shaft may have burrs or scratches. These need to be smoothed off prior to new seal install.

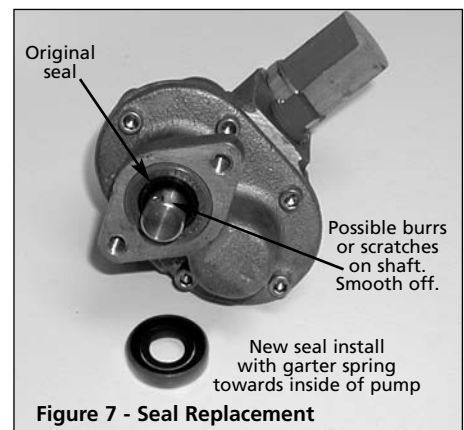

Figure 7 - Seal Replacement

- The relief valve is disassembled by removing the valve stem cap (6), valve stem lock nut (5), valve stem gasket (7), valve stem (4), valve spring (3), and the ball (2). Parts should be inspected for wear or damage. In particular, check inside the cover on the valve seat for pitting or damage.
- Inspect parts for damage or excessive wear. It is recommended, if pump components are worn, to replace the complete pump.
- Reassemble pump in reverse order of disassembly. Tighten cover screws evenly in opposing sequence to assure proper cover to body alignment.
- If the pump performs well but leaks, the lip seal should be replaced (See Figure 7). If there is excessive wear on gears, shafts or other pump components, the entire pump should be replaced.

## Contact a Shertech Distributor

Distributors can be found at [www.shertech.com](http://www.shertech.com) or [www.hyproindustrial.com](http://www.hyproindustrial.com)

(The factory only sells pumps and parts to distributors.)

Please provide following information:

- Model number
- Serial number (if any)
- Part description and number as shown in parts list

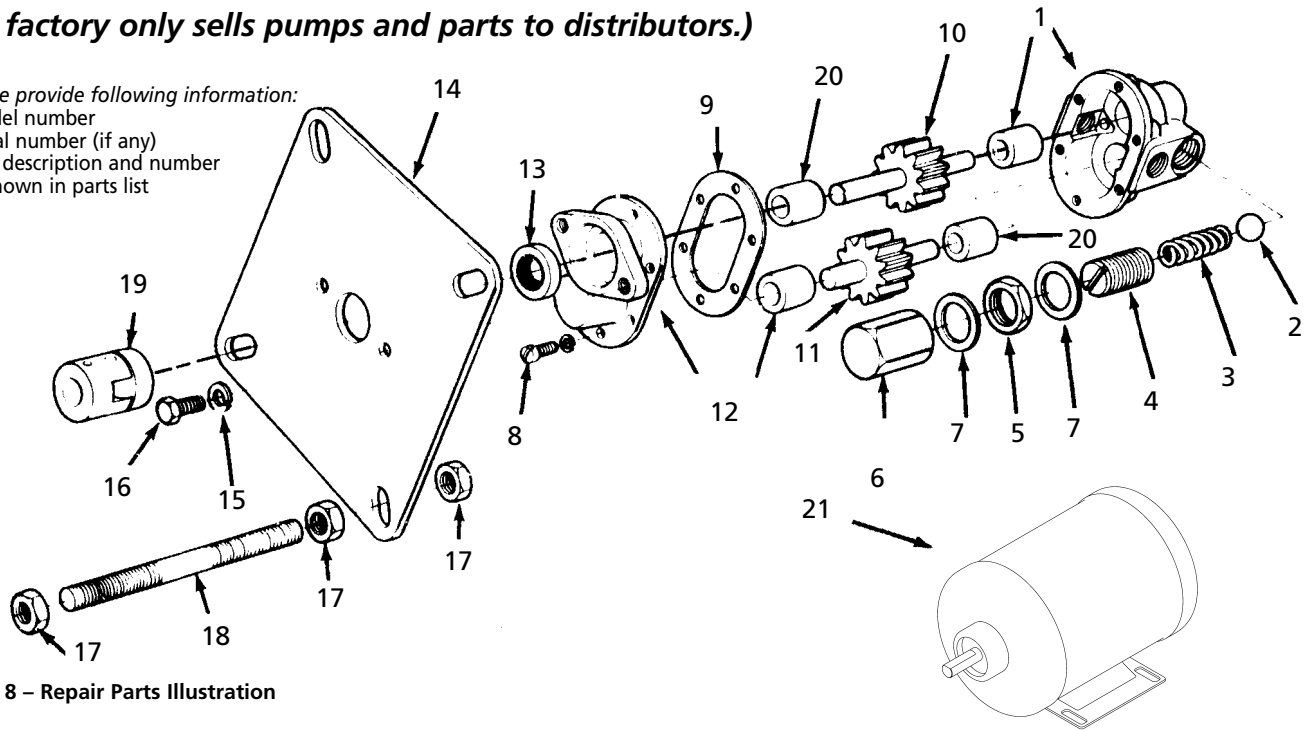

Figure 8 – Repair Parts Illustration

### Repair Parts List

Ref. No.	Description	GFBV2	GFBV3	GFBV22	GFBV33	Qty.
1	Housing assembly (Bronze) (includes carbon graphite bushings)	NA	NA	NA	NA	1
Optional	Housing Without Relief Valve **	115885	115875	115885	115875	1
2	Ball (300 Series SS)	NA	NA	NA	NA	1
3	Valve spring (17-7 SS)	NA	NA	NA	NA	1
4	Valve stem (Bronze)	NA	NA	NA	NA	1
5	Valve stem locknut	NA	NA	NA	NA	1
6	Valve stem cap	NA	NA	NA	NA	1
7	Valve gasket (Fiber)	NA	NA	NA	NA	2
8	Brass round head machine screw	*	*	*	*	6
9	Gasket (Vellumoid)	11582	11582	11582	11582	1
10	Driven gear & shaft assembly***	NA	NA	NA	NA	1
11	Drive gear & shaft assembly***	NA	NA	NA	NA	1
12	Body assembly (includes bushings)	NA	NA	NA	NA	1
13	Lip seal Buna-N (assemble with garter spring towards inside or body of pump)	11628	11628	11628	11628	1
Optional	Lip seal Viton	11674	11674	11674	11674	1
14	Mounting bracket (zinc-plated steel)	NA	NA	NA	NA	1
15	1/4" Light lockwasher	NA	NA	NA	NA	2
16	Long steel cap screw	NA	NA	NA	NA	2
17	Thin mounting nut	NA	NA	NA	NA	12
18	Mounting bolt	NA	NA	NA	NA	4
19	Flexible coupling (w/Spider)	NA	NA	NA	NA	1
20	Carbon Graphite Bushings (4)	NA	NA	NA	NA	4
21	Motor†	NA	NA	24647S	24648S	1
Optional	Replacement Pump Head Only*	GFBV2	GFBV3	GFBV2	GFBV3	1

(\* ) Pump heads come without plate, tie rods or shaft coupler.

(\*\* ) Replaces Ref. No. 1, but without relief valve porting. Comes with carbon bushings.

(\*\*\* ) Bronze gears on 303 SS shafts

(† ) See Specifications chart for motor specifications.

It is recommended that the pump be replaced once performance degrades such that the unit no longer satisfies the application. This is the most cost effective course of action as usually all parts have worn.

# Limited Warranty on **SHERTECH**<sup>®</sup> Bronze Plate-Mount Rotary Close-Coupled External Gear Pumps

Hypro warrants to the original purchaser of its products (the "Purchaser") that such products will be free from defects in material and workmanship under normal use for the period of six (6) months, and accessories will be free from defects in material and workmanship under normal use for the period of ninety (90) days. Parts carry no warranty.

"Normal use" does not include use in excess of recommended maximum speeds, pressures, vacuums and temperatures, or use requiring handling of fluids not compatible with component materials. This warranty does not cover freight damage, freezing damage, pump or motor damage from incorrect wiring (if equipped with motor), normal wear and tear, or damage caused by misapplication, fault, negligence, alterations, dry running pump, or repair that affects the performance or reliability of the product.

**THIS WARRANTY IS EXCLUSIVE. HYPRO MAKES NO OTHER WARRANTY, EXPRESS OR IMPLIED, INCLUDING BUT NOT LIMITED TO ANY WARRANTY OF MERCHANTABILITY OR FITNESS FOR A PARTICULAR PURPOSE.**

Hypro's obligation under this warranty is, at Hypro's option, to either repair or replace the product upon return of the entire product to the Hypro factory in accordance with the return procedures set forth below. **THIS IS THE EXCLUSIVE REMEDY FOR ANY BREACH OF WARRANTY.**

**IN NO EVENT SHALL HYPRO BE LIABLE FOR ANY INCIDENTAL OR CONSEQUENTIAL DAMAGES OF ANY KIND, WHETHER FOR BREACH OF ANY WARRANTY, FOR NEGLIGENCE, ON THE BASIS OF STRICT LIABILITY, OR OTHERWISE.**

Only authorized distributors can return products for Warranty. Contact your distributor or visit [www.shertech.com](http://www.shertech.com) to find a distributor for product support.

Distributors can obtain an RMA # and contact person's name by contacting Hypro's customer service at 800-471-0460.

## Return Procedures for Distributors

All pumps or products must be flushed of any chemical (ref. OSHA Section 0910.1200 (d)(e)(f)(g)(h) and hazardous chemicals must be labeled before being shipped\* to Hypro for service or warranty consideration. Hypro reserves the right to request a Material Safety Data sheet from the Purchaser for any pump or product Hypro deems necessary. Hypro reserves the right to "disposition as scrap" pumps or products returned without authorization and/or which contain unknown substances, or to charge for any and all costs incurred for chemical testing and proper disposal of components containing unknown substances. Hypro requests this in order to protect the environment and personnel from the hazards of handling unknown substances.

Be prepared to give Hypro full details of the problem, including the following information:

1. Model number, sale record/invoice, purchase date and from whom you purchased your pump.
2. A brief description of the pump problem, including the following:
  - Liquid pumped. State the pH and any non-soluble materials, and give the generic or trade name.
  - Temperature of the liquid and ambient environment.
  - Suction lift or vacuum (measured at the pump).
  - Discharge pressure.
  - Size, type, and mesh of the suction strainer.
  - Abrasiveness or particulate size in fluids.
  - Drive type (gas engine/electric motor; direct/belt drive; tractor PTO) and rpm of pump.
  - Viscosity of fluid if other than water.
  - Specific gravity of fluid if other than water.
  - Elevation from the pump to the discharge point.
  - Size and material of suction and discharge line.

Hypro may request additional information and may require a sketch to illustrate the problem. Distributors should contact the factory to receive a return material authorization before sending the product. All pumps returned for warranty work should be sent shipping charges prepaid to:

[RMA# and Contact Person]  
HYPRO  
375 Fifth Avenue NW  
New Brighton, Minnesota 55112

**NOTE:** Hypro reserves the right to "disposition as scrap" pumps or products returned without authorization.

\*Carriers, including U.S.P.S., airlines, UPS, ground freight, etc., require specific identification of any hazardous materials being shipped. Failure to do so may result in a substantial fine and/or prison term. Check with your shipping company for specific instructions.

# SHERTECH<sup>®</sup>



# HYPRO<sup>®</sup>

Pentair Water  
**INDUSTRIAL PRODUCTS GROUP**

375 Fifth Avenue NW • New Brighton, MN 55112  
Phone: (651) 766-6300 • 800-471-0460 • Fax: 800-672-7023  
[www.shertech.com](http://www.shertech.com) • [www.hyproindustrial.com](http://www.hyproindustrial.com)