

Please read and save this Repair Parts Manual. Read this manual and the General Operating Instructions carefully before attempting to assemble, install, operate or maintain the product described. Protect yourself and others by observing all safety information. The Safety Instructions are contained in the General Operating Instructions. Failure to comply with the safety instructions accompanying this product could result in personal injury and/or property damage! Retain instructions for future reference.

SHERTECH[®] Self-Priming Close-Coupled Centrifugal Pumps

In 316 Stainless Steel, Bronze and Cast Iron

Refer to form L-4077 for General Operating and Safety Instructions and Applicable Warranty.

Description

Shertech self-priming close-coupled cast iron, bronze or 316 stainless steel pumps produce high flow rates under low head conditions. Designed for continuous low pressure circulation and transfer of non-flammable liquids, water circulation, irrigation, spraying systems, jockey pump service, aggressive liquid applications and other general-purpose pumping compatible with pump component materials where suction lift is required.

- Capacities to 130 GPM, heads to 63 ft.
- 3/4 to 2 HP AC NEMA 56J frame single & three-phase TEFC motors. Single-phase motors are equipped with thermal overload protection. Overload protection not supplied on three-phase units and must be provided in starter units. Pump control box must be ordered separately.
- Pumps self-prime to 6 feet and handle liquids with entrapped gases.
- Designed to handle specific gravities up to 1.3 on 3/4 and 1½ HP models. On 2 HP models fluids with specific gravity of 1.1 can be handled. Note that with higher specific gravity or higher vapor pressure pump suction lift is reduced.
- Clog-resistant semi-open impellers handle solids to 3/8" diameter.
- Maximum viscosity to 100 SSU.
- Maximum torque allowed is 65 in.-lbs.
- Maximum casing working pressure is 75 PSI.
- 1½" female NPT inlet and outlet ports.
- Cast Iron and Bronze units handle temperatures to 200° F; 316 stainless steel units handle temperatures to 250° F.
- Seals: Pumps are equipped with a carbon ceramic mechanical seal having 316 stainless steel components. These seals protect the motor shaft, which is 300 series stainless steel, from chemical exposure. Buna-N seals are used in cast iron and Viton seal in bronze and 316 stainless steel models. Aftermarket options listed below.

REPAIR SEALS AND OPTIONS – Standard (Viton & Buna-N) and upgraded (Teflon[®] & Silicon Carbide) seals are available. If abrasive or small particulated fluids are being pumped, upgrade to the silicon carbide mechanical seal with Viton elastomers is recommended. See repair parts list in this manual for details.

PUMP HEADS AND PEDESTAL MOUNT BASE – Complete pump heads and pedestal base can be ordered. Pump head and pedestal model numbers are called out in the repair parts list in this manual.



Do not use to pump flammable or explosive fluids such as gasoline, fuel oil, kerosene, etc. Do not use in flammable and/or explosive atmospheres. When pumping hazardous or dangerous materials, use only in room or area designated for that purpose. For your protection, always wear proper clothing, eye protection, etc. in case of any malfunction. For proper handling techniques and cautions, contact your chemical supplier, insurance company and local agencies (fire dept., etc.). Failure to comply with this warning could result in personal injury and/or property damage.

SHERTECH® Self-Priming Close-Coupled Centrifugal Pumps 316 Stainless Steel, Bronze and Cast Iron Models

Model Ordering Codes and Options

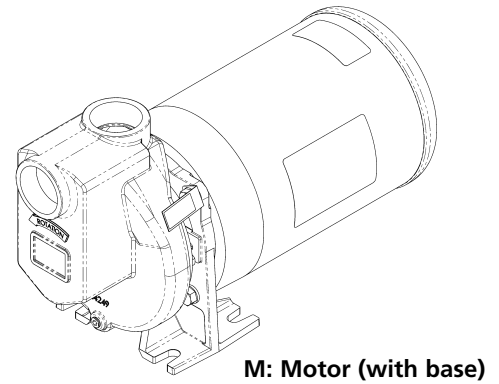
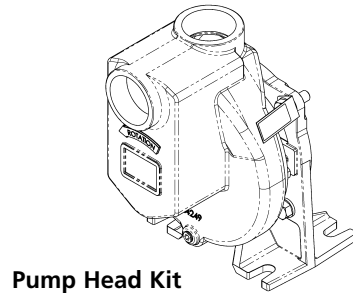
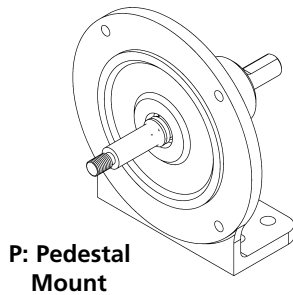

Example Model: CSMSV62 (1/2 HP ODP motor with >1.15 Service Factor*)
or
CSMSV63T (3/4 HP TEFC motor with 1.0 Service Factor*)

1st	2nd	3rd	4th	5th	6th	7th
Series	Mounting	Material	Seal** (Mech)	Impeller Sz. (NPT Ports)	Motor-Mounted Only	
					HP	AC Type
CS: Centrifugal Self Prime and Semi-open Impeller	M: Motor (with cast pump frame base mount) P: Pedestal	S: 316 SS Body and Impeller B: Bronze Body and 316 SS Impeller C: Cast Iron Body and Impeller	B: Buna-N (Stainless Steel Case) C: Viton (Stainless Steel Case) (Silicon Carbide Seal and Seat Faces) P: Viton (Carbon/Ceramic Case) T: Teflon (Stainless Steel Case)	6 (1½" - 1½") 7 (1½" - 1½") 8 (1½" - 1½") <i>To identify your impeller size see chart on page 12.</i>	1: 1/3 2: 1/2 3: 3/4 4: 1 5: 1½ 6: 2 7: 3 X: 56J Frame Motor "wet-end kit" Example: CSMSV6X	Blank: no code single phase ODP motor 3: 3 phase ODP motor T: 1 phase TEFC 3T: 3 phase TEFC

NOTE: Not all order code combinations (configurations) are standard models available from the manufacturer. Custom model configurations may require ordering standard components and/or optional parts that will need to be assembled by the customer. Manufacturer reserves the right to change model order codes, standard models, specifications, and performance without notification.
(*) ODP motors have > 1.15 service factors. Due to service factor, it is recommended TEFC motors are oversized by one HP increment. Pedestal Pumps are not supplied with a motor.
(**) Unless otherwise noted, seal faces are carbon on ceramic.

316 Stainless Steel, Bronze and Cast Iron Models

Performance – Standard Models (Water at 70°)

316 Stainless Steel Models	Model Bronze Models	Cast Iron Models	3450 RPM Pump Driven Speed							Max. Head*	Max. Spec. Gravity
			GPM of Water at Total Head in Feet*								
			0	10	20	30	40	50	60		
CSMSV6X	CSMSV6X	CSMSV6X	69	61	52	42	24	4	–	52	1.3
CSMSV63T	CSMBV63T	CSMCB63T	69	61	52	42	24	4	–	52	1.3
CSMSV633T	CSMBV633T	CSMCB633T	69	61	52	42	24	4	–	52	1.3
CSMSV7X	CSMSV7X	CSMSV7X	100	91	79	66	48	7	–	52	1.3
CSMSV75T	CSMBV75T	CSMCB75T	100	91	79	66	48	7	–	52	1.3
CSMSV753T	CSMBV753T	CSMCB753T	100	91	79	66	48	7	–	52	1.3
CSMSV8X	CSMBV8X	CSMCB8X	130	123	113	99	82	61	26	63	1.1
CSMSV863T	CSMBV863T	CSMCB863T	130	123	113	99	82	61	26	63	1.1

(*) Test data is taken with water at 70°F for pumps with 60 Hz motors at 3450 RPM motors (to convert data to PSI, divide feet of head by 2.31). Pump performance when pump is new. As pump wears, the performance will decrease.

NOTES: Max Viscosity 100 SSU
 Max Specific Gravity 1.1-1.3
 Max Torque 65 in.-lbs.
 Max suction lift to 6 ft.
 Manufacturer reserves the right to change performance without notification.

SHERTECH® Self-Priming Close-Coupled Centrifugal Pumps

316 Stainless Steel, Bronze and Cast Iron Models

Specifications – Standard Models

Model Number	HP	AC Motor Type	DRIVER								PUMP CONSTRUCTION (Wet End)						Ship Wt. (lbs.)	
			NEMA Frame	Motor Voltage	Load Amps	Full Factor Amps	Ser Hz	Phase	Overload Protection	RPM	Port Motor Shaft	Size FNPT	Housing	Impeller	Adapter	Seals*		
316 Stainless Steel Models																		
CSMSV6X	3/4	-	56J	-	-	-	-	-	-	-	3450	1½ x 1½	303 SS	316 SS	316 SS	Viton	45	
CSMSV63T	3/4	TEFC	56J	115/230	9.8/4.9	10.8/5.4	60	1	Yes	3450	1½ x 1½	303 SS	316 SS	316 SS	316 SS	Viton	45	
CSMSV633T	3/4	TEFC	56J	208-220/440	3.2/1.6	3.3/1.65	50/60	3	No	3450	1½ x 1½	303 SS	316 SS	316 SS	316 SS	Viton	40	
CSMSV7X	1½	-	56J	-	-	-	-	-	-	-	3450	1½ x 1½	303 SS	316 SS	316 SS	316 SS	Viton	55
CSMSV75T	1½	TEFC	56J	115/230	17.4/8.7	18.4/9.2	60	1	Yes	3450	1½ x 1½	303 SS	316 SS	316 SS	316 SS	Viton	55	
CSMSV753T	1½	TEFC	56J	208-220/440	4.6/2.3	5.0/2.5	50/60	3	No	3450	1½ x 1½	303 SS	316 SS	316 SS	316 SS	Viton	48	
CSMSV8X	2	-	56J	-	-	-	-	-	-	-	3450	1½ x 1½	303 SS	316 SS	316 SS	316 SS	Viton	50
CSMSV863T	2	TEFC	56J	208-220/440	6.0/3.0	6.4/3.2	50/60	3	No	3450	1½ x 1½	303 SS	316 SS	316 SS	316 SS	Viton	50	
Bronze Models																		
CSMBV6X	3/4	-	56J	-	-	-	-	-	-	-	3450	1½ x 1½	303 SS	BR	316 SS	BR	Viton	45
CSMBV63T	3/4	TEFC	56J	115/230	9.8/4.9	10.8/5.4	60	1	Yes	3450	1½ x 1½	303 SS	BR	316 SS	BR	Viton	45	
CSMBV633T	3/4	TEFC	56J	208-220/440	3.2/1.6	3.3/1.65	50/60	3	No	3450	1½ x 1½	303 SS	BR	316 SS	BR	Viton	40	
CSMBV7X	1½	-	56J	-	-	-	-	-	-	-	3450	1½ x 1½	303 SS	BR	316 SS	BR	Viton	55
CSMBV75T	1½	TEFC	56J	115/230	17.4/8.7	18.4/9.2	60	1	Yes	3450	1½ x 1½	303 SS	BR	316 SS	BR	Viton	55	
CSMBV753T	1½	TEFC	56J	208-220/440	4.6/2.3	5.0/2.5	50/60	3	No	3450	1½ x 1½	303 SS	BR	316 SS	BR	Viton	48	
CSMBV8X	2	-	56J	-	-	-	-	-	-	-	3450	1½ x 1½	303 SS	BR	316 SS	BR	Viton	50
CSMBV863T	2	TEFC	56J	208-220/440	6.0/3.0	6.4/3.2	50/60	3	No	3450	1½ x 1½	303 SS	BR	316 SS	BR	Viton	50	
Cast Iron Models																		
CSMCB6X	3/4	-	56J	-	-	-	-	-	-	-	3450	1½ x 1½	303 SS	CI	CI	CI	Buna-N	45
CSMCB63T	3/4	TEFC	56J	115/230	9.8/4.9	10.8/5.4	60	1	Yes	3450	1½ x 1½	303 SS	CI	CI	CI	Buna-N	45	
CSMCB633T	3/4	TEFC	56J	208-220/440	3.2/1.6	3.3/1.65	50/60	3	No	3450	1½ x 1½	303 SS	CI	CI	CI	Buna-N	40	
CSMCB7X	1½	-	56J	-	-	-	-	-	-	-	3450	1½ x 1½	303 SS	CI	CI	CI	Buna-N	55
CSMCB75T	1½	TEFC	56J	115/230	17.4/8.7	18.4/9.2	60	1	Yes	3450	1½ x 1½	303 SS	CI	CI	CI	Buna-N	55	
CSMCB753T	1½	TEFC	56J	208-220/440	4.6/2.3	5.0/2.5	50/60	3	No	3450	1½ x 1½	303 SS	CI	CI	CI	Buna-N	48	
CSMCB8X	2	-	56J	-	-	-	-	-	-	-	3450	1½ x 1½	303 SS	CI	CI	CI	Buna-N	50
CSMCB863T	2	TEFC	56J	208-220/440	6.0/3.0	6.4/3.2	50/60	3	No	3450	1½ x 1½	303 SS	CI	CI	CI	Buna-N	50	

SS = Stainless Steel BR = Bronze CI = Cast Iron ODP = Open Drip Proof TEFC = Totally Enclosed Fan Cooled
(*) Shaft Seals also contain 316 stainless steel, ceramic, and carbon components.

NOTES: Driver data is subject to change without notice. See label on driver for actual information.

"X" Models have no driver.

Manufacturer reserves the right to change specifications without notification.

316 Stainless Steel, Bronze and Cast Iron Models

Dimensions (Inches)

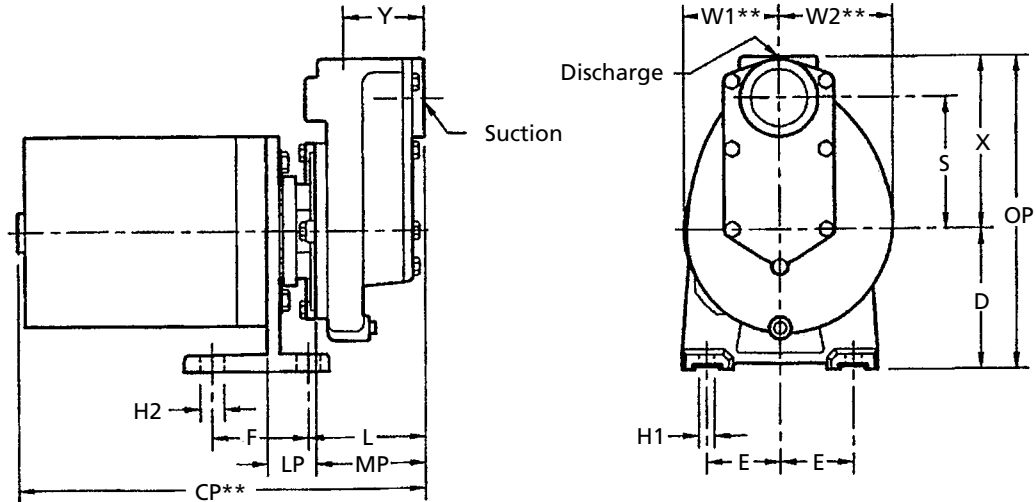

Figure 1 - Dimensions

316 SS	Models Bronze	Cast Iron	Suc.*Dis.*	CP**	D	E	F	H1	H2	L	LP	MP	OP	S	W1**W2**	X	Y
CSMSV64T	CSMBV63T	CSMCB63T	1.50 1.50	15.13	4.25	2.25	3.00	0.50	0.75	4.31	1.50	4.38	9.50	4.00	2.88 3.50	5.25	3.81
CSMSV75T	CSMBV75T	CSMCB75T	1.50 1.50	16.63	4.25	2.25	3.00	0.50	0.75	4.31	1.50	4.38	9.50	4.00	2.88 3.50	5.25	3.81
CSMSV633T	CSMBV633T	CSMCB633T	1.50 1.50	14.50	4.25	2.25	3.00	0.50	0.75	4.31	1.50	4.38	9.50	4.00	2.88 3.50	5.25	3.81
CSMSV753T	CSMBV753T	CSMCB753T	1.50 1.50	15.63	4.25	2.25	3.00	0.50	0.75	4.31	1.50	4.38	9.50	4.00	2.88 3.50	5.25	3.81
CSMSV863T	CSMBV863T	CSMCB863T	1.50 1.50	15.63	4.25	2.25	3.00	0.50	0.75	4.31	1.50	4.38	9.50	4.00	2.88 3.50	5.25	3.81

SS = Stainless Steel.

(*) Standard NPT (female) pipe thread.

(**) This dimension may vary due to motor manufacturing specifications.

NOTE: All dimensions have a tolerance of $\pm 1/8"$.

SHERTECH® Self-Priming Close-Coupled Centrifugal Pumps

316 Stainless Steel, Bronze and Cast Iron Models

Maintenance

⚠ WARNING *Make certain that the power source is disconnected before attempting to service or disassemble any components! If the power disconnect is out-of-sight, lock it in the open position and tag to prevent application of power.*

MECHANICAL SEAL REPLACEMENT

Refer to Figures 2, 3 and 4.

IMPORTANT: Always replace both the seal seat and the seal cartridge as an assembly to ensure proper mating of components! It is recommended that the impeller O-ring (Ref. No. 14) also be replaced when replacing the pump seal.

1. Unthread cap screws (Ref. No. 7) and remove housing (Ref. No. 16) and O-ring (Ref. No. 8).

⚠ CAUTION *Care should be taken to not pinch or "shave" the o-ring gasket (Ref. No. 8) between the casing housing and casing housing cover.*

2. Unscrew impeller lock nut (Ref. No. 15) from the motor shaft (lock nut unscrews CCW looking at motor shaft).

NOTE: Some motors use an open end 7/16" wrench across flats on the rear of the motor shaft (remove bearing cap for access) to prevent shaft from turning. Other motor shafts have a screwdriver slot instead of flats.

3. Unscrew impeller (Ref. No. 13) from motor shaft. Remove the impeller O-ring (Ref. No. 14) and clear all sediment from impeller. Inspect the impeller O-ring, replace if deeply scarred or worn. Also, remove shims (Ref. No. 9) **DO NOT LOSE SHIMS.**
4. Remove the adapter and casing housing cover (Ref. No. 3 and 6) by unthreading four fasteners (Ref. No. 4 and 5).

5. Press seal cartridge to remove (Ref. No. 10) from the rear of the casing housing cover (Ref. No. 6) using a wooden dowel.
6. Remove seal seat (Ref. No. 11) from recess of impeller (Ref. No. 13). Use caution so as not to damage or remove seal seat pin (Ref. No. 12) on Teflon seal-equipped units.
7. Clean casing housing cover and impeller seal recesses and motor shaft (Ref. No. 13). Make certain all surfaces are perfectly clean before installing new seal parts.

⚠ CAUTION *Handle seal parts with extreme caution and keep them clean. Do not touch seal faces (either ceramic or carbon) with your hands. Do not apply lubricants on seal faces. This could cause a leak or premature seal failure.*

8. Apply a light coat of sealing compound to new seal cartridge (See Figure 2) and press it into the casing housing cover recess (Ref. No. 6) using the proper size tube or installation tool (See Figure 3). **DO NOT** press on carbon face or top of metal cup of the seal cartridge. Install using flange only.

9. Bolt the adapter (Ref. No. 3) and casing housing cover (Ref. No. 6) assembly onto motor mounting face. Fasten with four fasteners.
10. Press new seal seat (Ref. No. 11) squarely into the impeller recess (Ref. No. 13). Align slot in the seal seat with seal seat pin on Teflon-equipped units. Avoid scratching the ceramic surface. Use the cardboard washer (usually supplied with new seal) to place over the polished ceramic surface and use a piece of pipe or dowel rod to press in firmly but gently (See figure 2). Avoid scratching the ceramic face, usually white.

Dispose of cardboard washer. Check again to see that ceramic surface is free of dirt and all other foreign particles and that it has not been scratched or damaged.

NOTE: Use a soft, clean piece of cloth on seal seat face when installing to prevent scratching.

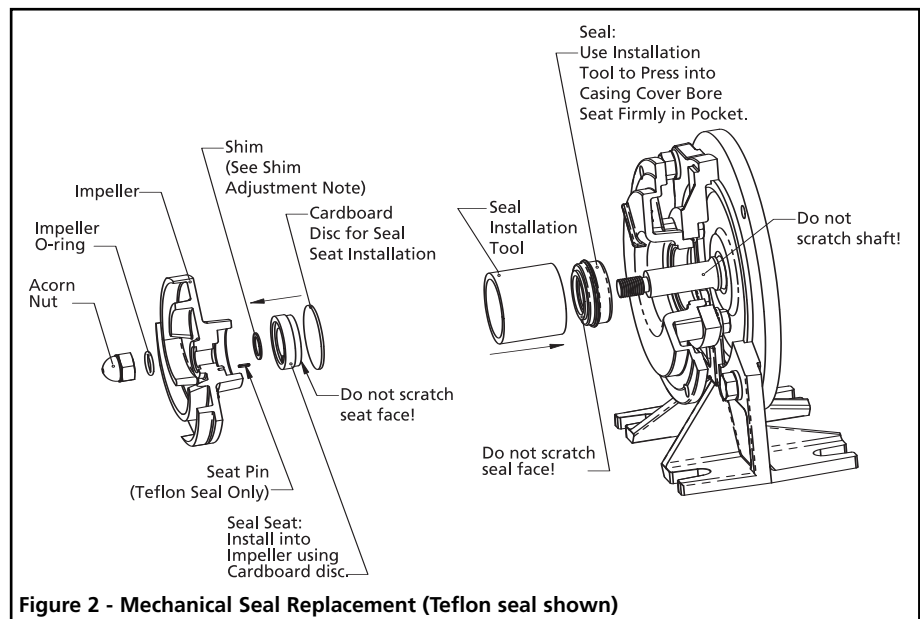

316 Stainless Steel, Bronze and Cast Iron Models

11. Replace any shim washers (Ref. No. 9) which may have been removed in disassembly (see SHIM ADJUSTMENT).

Screw the impeller (Ref. No. 13) back in place, tightening until it is firmly seated.

12. Install the impeller O-ring (Ref. No. 14), and install and tighten impeller lock nut to 200 to 225 lbs. (Ref. No. 15).

NOTE: It will be necessary to remove plug in motor end cap to expose slot. If removed, be sure to reinstall plug AFTER pump is completely assembled.

13. Reinstall o-ring seal (Ref. No. 8) on casing cover rabbet (Ref. No. 6). Remount pump housing with six fasteners (Ref. No. 7).

NOTE: A short "run-in" period may be necessary to provide completely leak-proof seal operation.

NOTE: Always flush pump thoroughly before use so as not to contaminate liquid being pumped.

CAUTION *If the impeller is replaced, the seal assembly should also be replaced as the seal is usually damaged in disassembly. Also replace impeller washer.*

SHIM ADJUSTMENT

When installing a replacement impeller (Ref. No. 13) or motor (Ref. No. 1), it may be necessary to adjust the number of shims (Ref. No. 9) to ensure proper running clearance between the impeller and the casing. Proceed as follows:

NOTE: A proper running clearance is less than 0.010". (Face of impeller to mating face of casing housing.)

1. For the impeller replacement, add one (1) shim (thinnest 0.005") in addition to the one (1) removed originally.

2. For motor replacement, add one (1) shim (0.015") in addition to the shims removed during disassembly. The impeller must be firmly tightened on the shaft. (to 180 in-lbs torque) The jam nut (Acorn nut Ref. No. 15) must be tightened to 200-220 in-lbs.

3. Reassemble the pump as described in Steps 11, 12, and 13.

IMPORTANT: Ensure that the casing is snugly in place and check the shaft to make sure it is turning freely. (Use 7/16" wrench or screwdriver to turn the shaft.) If it turns freely, check to ensure that the adapter and casing housing are fitted "metal to metal" where they meet on the outside. If they are not "metal to metal", tighten the fasteners (Ref. No. 2, 5, and 7) and recheck the shaft for free turning. Tighten carefully, turning the shaft while tightening so that the motor bearings are not damaged in the event that too many shims were installed. If shaft seizes before fasteners are completely tight, disassemble the pump and remove one (1) shim (thinnest 0.005") and repeat reassembly.

CAUTION *Seal will produce some minor drag when spinning motor shaft, but rubbing anywhere else must be eliminated! Otherwise, damage to pump and/or motor may occur.*

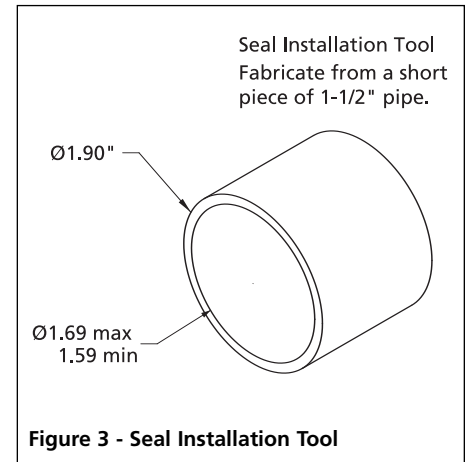

Contact a Shertech Distributor

Distributors can be found at www.shertech.com or www.hyproindustrial.com

(The factory only sells pumps and parts to distributors.)

Please provide following information:

- Model number
- Serial number (if any)
- Part description and number as shown in parts list

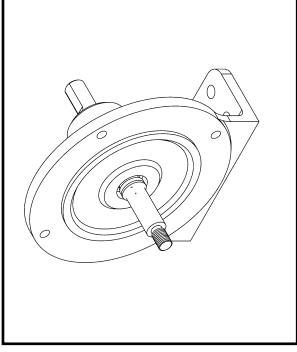

Optional pedestal mount.

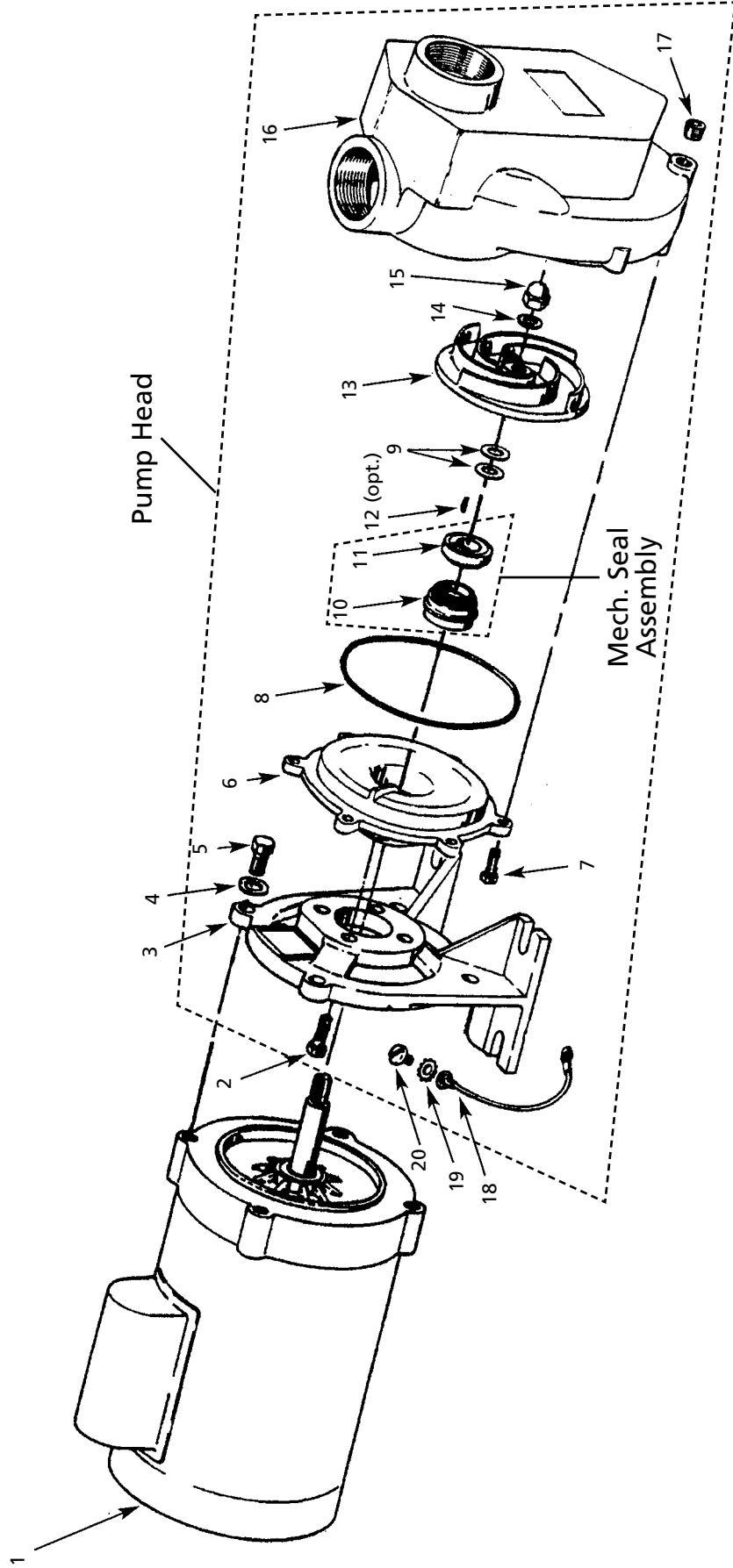

Figure 4 – Repair Parts Illustration

Repair Parts List

Ref. No.	Description	316 SS Units	Bronze Units	Cast Iron Units	Qty
1 ***	3/4 HP 1 PH TEFC Motor for CSM5V63T, CSMBV63T, & CSMCB63T 1-1/2 HP 1 PH TEFC Motor for CSM5V75T, CSMBV75T, & CSMCB75T 3/4 HP 3PH TEFC Motor for CSM5V633T, CSMBV633T, & CSMCB633T 1-1/2 HP 3 PH TEFC Motor for CSM5V753T, CSMBV753T, & CSMCB753T 2 HP 3 PH TEFC Motor for CSM5V863T, CSMBV863T, & CSMCB863T	13409H 13410H 14017H 14018H 19495H	13409H 13410H 14017H 14018H 19495H	13409H 13410H 14017H 14018H 19495H	1
2	5/16-18 Serrated Flange Bolt (18-8 Stainless Steel) †	24386	24386	24386	4
3	Motor Adapter	24248	24248	24248	1
4	3/8 Lock Washer (18-8 Stainless Steel) †	2260-0012	2260-0012	2260-0012	4
5	3/8-16 Hex Head Cap Screw, (18-8 Stainless Steel) †	2210-0100	2210-0100	2210-0100	4
6	Casing Cover	24437S	24437B	24437C	1
7	1/4-20 Hex Head Cap Screw, (18-8 Stainless Steel) †	17485	17485	17485	6
8	O-ring Seal (Standard) Buna-N O-ring * Viton O-ring * Teflon Encapsulated Viton O-ring *	18104 24372 standard 24312 24337	18104 24372 standard 24312 24337	18104 standard 24312 24337	1
9	Impeller Shim Pack	24337	24337	24337	1
10&11	Seal / Seat Assy (Standard) Seal Assembly (Viton / Carbon / Ceramic) * 1 Seal Assembly (Buna-N / Carbon / Ceramic) * 2 Seal Assembly (Teflon / Carbon / Ceramic, includes item 12) * 3 Seal Assembly (Viton / Silicon Carbide) * 1 Seal Anti-Rotation Pin (used only with Teflon seal)	13263S standard 24443S 24435S 24466S 24302 24385	13263S standard 24443S 24435S 24466S 24302 24438S	24443S 13263S standard 24435S 24466S 24302 24438C	1
12	Impeller 0.75 HP Models CSM5V63T, CSMBV63T, CSMCB63T, CSM5V633T, CSMBV633T, & CSMCB633T	24439S	24439S	24439C	1
13	Impeller 1-1/2 HP Models CSM5V75T, CSMBV75T, CSMCB75T, CSM5V753T, CSMBV753T, & CSMCB753T	24440S	24440S	24440C	1
14	Impeller 2 HP Models CSM5V863T, CSMBV863T, & CSMCB863T Impeller O-ring (standard) O-ring Buna-N * O-ring Viton * O-ring Teflon Encapsulated Viton *	24314 22937 standard 24312 24299 24249S	24314 22937 standard 24312 2250-0084 24249B	24314 standard 24312 2250-0084 24249C	1
15	Low Crown Acorn Nut (316 SS on Stainless Steel Pumps) ³	24308	24389	24390	1
16	Pump Housing	24387	24387	24387	1
17	Pipe Plug, 1/8 NPT	2260-0023	2260-0023	2260-0023	1
18	Ground Wire	24388	24388	24388	1
19	1/4 External Tooth Lock Washer (18-8 Stainless Steel) †				
20	1/4-20 Pan Head Screw - Phillips, (18-8 Stainless Steel) †				

NOTES:

- SS = Stainless Steel
- (†) Standard Hardware Item, Available Locally
- (*) Optional
- (1) Seals also contain 316 stainless steel components, and have Viton bellows.
- (2) Seals also contain 316 stainless steel components, and have Buna-N bellows.
- (3) Seals also contain 316 stainless steel components, and have Teflon wedge.
- *** Drive is subject to change without notice, see label on drive for actual specifications. IN motor description PH = phase.

Optional Pedestal Bracket

(Can be substituted for any motor when a pulley drive or long coupled pump is desired, See Figure 5 for dimensional data.)

Complete Pump Heads, large volute with standard seal (no motor)

- 3/4 HP Pump Head
- 1-1/2 HP Pump Head
- 2 HP Pump Head

24479

24479

24479

24479

24479

24479

24479

CSMCB6X
CSMCB7X
CSMCB8X

CSMBV6X
CSMBV7X
CSMBV8X

CSMSV6X
CSMSV7X
CSMSV8X

CSMBV6X
CSMBV7X
CSMBV8X

CSMBV6X
CSMBV7X
CSMBV8X

CSMBV6X
CSMBV7X
CSMBV8X

CSMBV6X
CSMBV7X
CSMBV8X

SHERTECH® Self-Priming Close-Coupled Centrifugal Pumps **316 Stainless Steel, Bronze and Cast Iron Models**

(Optional) Pedestal Pump Mount Part Number 24479
(Replaces 56J frame motor)
(When long coupling or pulley drive is required)

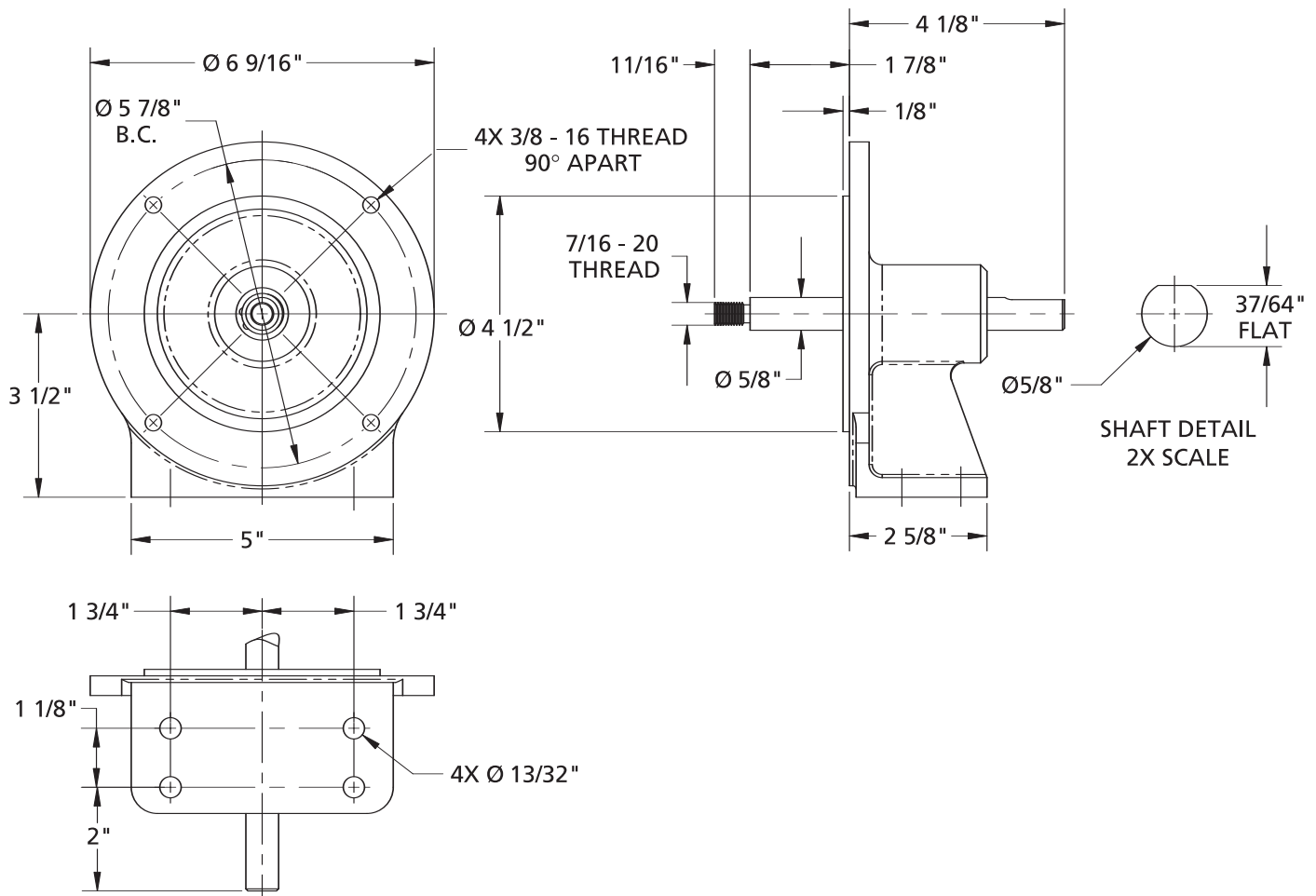

Figure 5

NOTE: Dimensions have a tolerance of $\pm 1/8$ ".
(Ø) Diameter.

316 Stainless Steel, Bronze and Cast Iron Models

Troubleshooting Chart

Symptom	Possible Cause(s)	Corrective Action
Pump runs but no fluid	<ol style="list-style-type: none"> 1. Faulty suction piping 2. Pump located too far from fluid source 3. Gate valve closed 4. Clogged strainer 5. Fouled foot valve 6. Discharge height too great 7. Suction lift too great 	<ol style="list-style-type: none"> 1. Replace 2. Relocate 3. Open 4. Clean or replace 5. Clean or replace 6. Lower the height 7. Lower pump
Pump will not prime or retain prime after operating	<ol style="list-style-type: none"> 1. Air leak in suction line 2. Clogged foot valve or strainer 3. Specific gravity too high 4. Viscosity of fluid too high 5. Vapor pressure of fluid too high 	<ol style="list-style-type: none"> 1. Repair or replace 2. Clean or replace 3. 4 & 5 Reduce height of suction lift from fluid by reducing height of pump from fluid or use a pump appropriate for the fluid being pumped
Pump starts and stops pumping	<ol style="list-style-type: none"> 1. Fouled impeller 2. Faulty mechanical seal 3. Leak in suction line 4. Leak in foot valve 	<ol style="list-style-type: none"> 1. Clean 2. Replace 3. Repair 4. Repair or replace
Flow rate is low	<ol style="list-style-type: none"> 1. Incorrect speed 2. Piping is fouled or damaged 3. Clogged impeller or worn impeller 4. Discharge line restricted or undersized 5. High discharge pressure 	<ol style="list-style-type: none"> 1. Check drive 2. Clean or replace 3. Clean or replace 4. Flush out piping or replace 5. Check and reduce
Excessive noise while pump in operation	<ol style="list-style-type: none"> 1. Pump not secured to firm foundation 2. Piping not supported to relieve strain on pump assembly 3. Restricted suction line 4. Cavitation (noise like marbles in pump) 	<ol style="list-style-type: none"> 1. Secure properly 2. Make necessary adjustments 3. Clean or correct 4. a. Reduce speed b. Increase inlet size c. Too viscous (thickness of material being pumped too large)
Liquid drips from point where shaft enters the pump casing when pump is full of liquid	<ol style="list-style-type: none"> 1. Damaged mechanical seal 2. Temperatures over 200°F – on Cast Iron and Bronze or 250°F on Steel 	<ol style="list-style-type: none"> 1. Replace (See Mechanical Seal Replacement) 2. Lower fluid temperature
Pump runs but poor performance	<ol style="list-style-type: none"> 1. Check pump rotation to see if it is CCW as viewed from motor face. On three-phase motors, rotation must be checked prior to running pump under load. 	<ol style="list-style-type: none"> 1. On three-phase motors switch any two motor wire leads to reverse rotation.

⚠ WARNING Failure to check rotation before pump is run can result in severe damage to the pump and motor unit.

SHERTECH® Self-Priming Close-Coupled Centrifugal Pumps **316 Stainless Steel, Bronze and Cast Iron Models**

Impeller Identification Chart

-Semi Open-

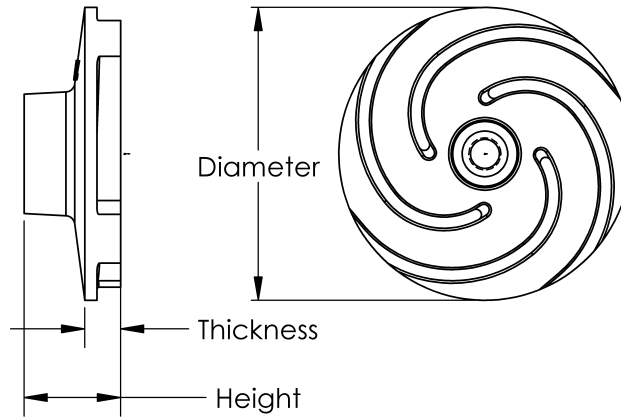

Impeller Identification Chart

Size	HP	316 SS Impeller	Cast Iron Impeller	Diameter (inches)	Thickness (inches)	Height (inches)
6	3/4	24438S	24438C	3.94	0.48	1.3
7	1-1/2	24439S	24439C	3.94	0.40	1.3
8	2	24440S	24440C	4.31	0.42	1.3

SHERTECH®



Pentair Water
INDUSTRIAL PRODUCTS GROUP

375 Fifth Avenue NW • New Brighton, MN 55112

Phone: (651) 766-6300 • 800-471-0460 • Fax: 800-672-7023

www.shertech.com • www.hyproindustrial.com