



MARINE PRODUCT DATA SHEET

OEM: 357-103-00 (1100 GPH)
AFTERMARKET: 357-103-10 (1100 GPH)

Everything you are looking for in a livewell pump. Our tough, high density nylon housing and heavy duty water cooled motor give the SHURflo Livewell Pumps unparalleled reliability. Patented anti-airlock feature allows the pump to clear trapped air in rough water or when the boat is anchored. The dual port fitting allows for easy washdown pump connections. All Piranha Series Livewell Pumps have a removable cartridge for easy cleaning.

TYPICAL APPLICATIONS

12V DC Bait/Livewell Application. For other applications, contact SHURflo.

PUMP

Type: Centrifugal Pump
Output Port: 1 1/8" Barb
Intake Port: 3/4" NPT-M
Wash Down Port: 1/2" NPT-F
Liquid: 130 °F [54 °C] Max
Prime: Flooded Inlet
Inlet PSI: 30 PSI [2.1 Bar] Max
Run Dry: No

ELECTRICAL

Motor: 12VDC Permanent Magnet, Continuous Duty
Protection: External Fuse
Leads: 6 ft (1.8M) Tinned, 16 AWG
Fuse: 6 Amp Recommended
Control: No Control

MATERIALS

Housing: High Strength Nylon
Impeller: High Strength Nylon
Hardware: Stainless Steel

APPROVALS

Ignition Protected, CE, ISO 8846

WARRANTY

3 Year Limited Warranty
See SB-1050 For Full Warranty Details

SHIPPING

Net Weight (Boxed): 1.3 Lb (0.59 Kg) each
Carton Weight: 31 Lb [14 Kg]
Pumps in Carton: 24
Carton Size: 24"L x 18"W x 11" H [61 cm x 46 cm x 28 cm]

RELATED DOCUMENTS

Catalog: MS-030-140
Installation Manual: 911-611-00
Maintenance: 911-611-00
Applications Spec Guide: MS-020-005
Warranty: SB-1050

Replacement Kit

94-620-00



PERFORMANCE @ 13.6V DC

| PRESSURE | | FLOW | | CURRENT |
|----------|------------|------|------|---------|
| METERS | FT OF HEAD | GPH | LPH | AMPS |
| 0.0 | 0 | 1185 | 4485 | 4.50 |
| 1.2 | 4 | 780 | 2952 | 4.12 |
| 1.8 | 6 | 630 | 2384 | 4.07 |
| 2.4 | 8 | 510 | 1930 | 3.93 |
| 4.6 | 15 | 0.0 | 0.0 | 3.27 |

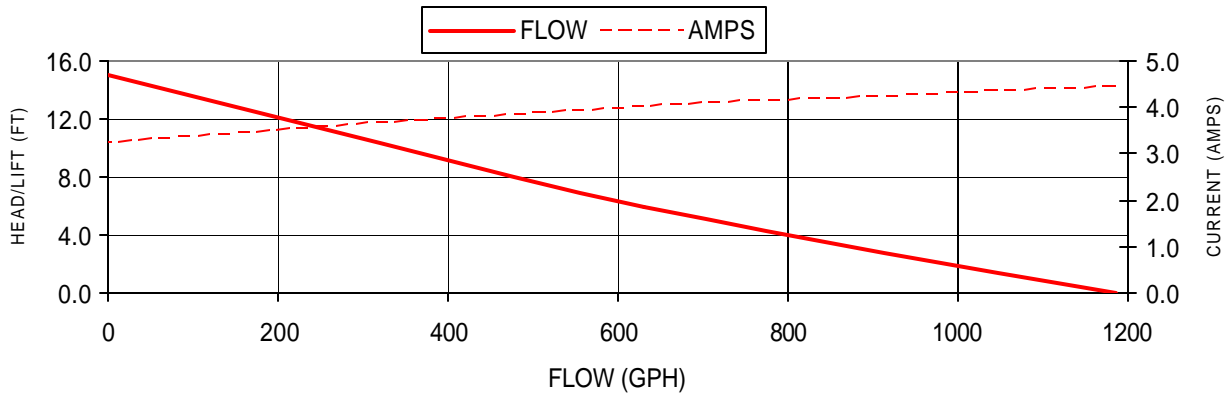

DIMENSIONS [mm]

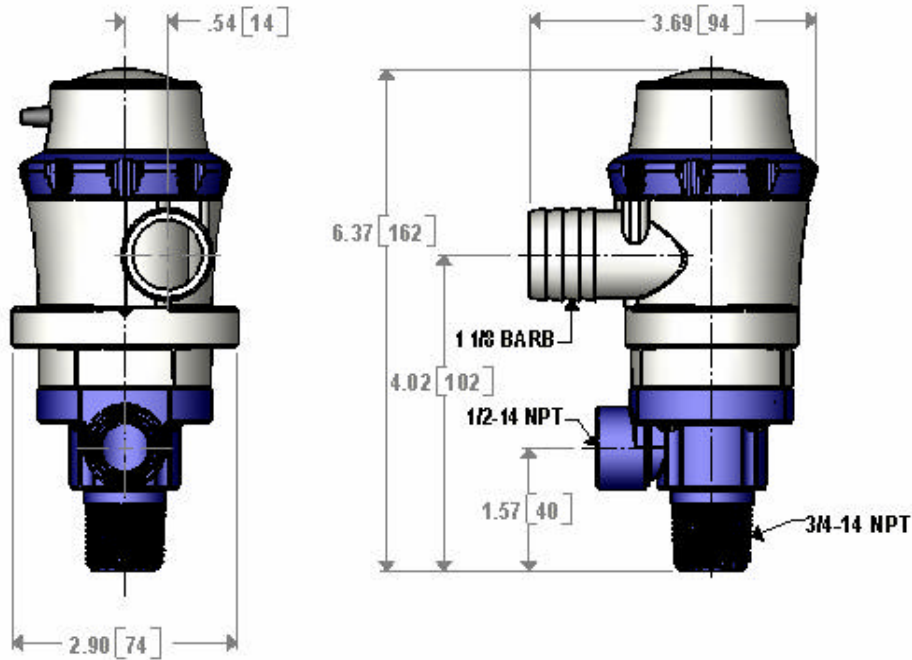

*ISO Registered Facility

SHURflo reserves the right to update specifications, prices, or make substitutions.



SHURflo, LLC*
 5900A Katella Ave.
 Cypress, Ca. 90630
 Phone: 800 854 3218
 Fax: 562 795 7554
 Shipping: 5900C Katella Ave.
 Cypress, Ca. 90630

SHURflo East
 52748 Park Six Court
 Elkhart, IN 46514-5427
 Phone: 800 854 3218
 Fax: 574 264 2169
 Http://www.shurflo.com
 © 2001

SHURflo Ltd.*
 Unit 5, Sterling Park
 Gatwick Road, Crawley
 West Sussex, RH10 9QT
 United Kingdom
 Phone: 0044 (0) 1293 424 000
 Fax: 0044 (0) 1293 421 880