

### TYPICAL APPLICATIONS

Multi-fixture RV potable water installations.  
Other uses may include 24 VDC pressurized water systems in cabins. This pump may be used for general water transfer. For other applications, contact SHURflo.

### PUMP

Type	3 Chamber Diaphragm
Ports	1/2"-14 NPSM-Male
Liquid	130 °F [54 °C] Max
Prime	9 feet [2.7 M]
Inlet PSI	30 PSI [2.1 Bar] Max
Run Dry	Yes

### ELECTRICAL

Motor	24VDC Permanent Magnet, Intermittent Duty	
Protection	Thermal Overload, Automatic Restart	
Leads	16 AWG, 16" [40 cm] Red +, 13" [33 cm] Black -	
Fuse	5 Amp Time Delay Recommended	
Control	Adjustable Switch with Check Valve	
	Shut-Off	30 PSI [2.1 Bar] ± 5 PSI [0.4 Bar]
	Restart	18 PSI [1.2 Bar] ± 5 PSI [0.4 Bar]

### MATERIALS

Housing	Polypropylene
Valves	EPDM
Diaphragm	Santoprene
Hardware	Zinc Plated Steel

### APPROVALS

c-UL

### WARRANTY

2 Year Limited Warranty  
See SB-1041 For Full Warranty Details

### SHIPPING

Net Weight (Boxed)	5 Lb [2.3Kg] each
Carton Weight	12 each, 52 Lb [24 Kg]
Carton Size	24"L x 18"W x 11"H [61cm x 46cm x 28cm]

### RELATED DOCUMENTS

Catalog	MS-030-083
Installation Manual	911-352
Maintenance	911-352
Applications Spec Guide	MS-020-005
Warranty	SB-1041

### Aqua King



### Parts Kits

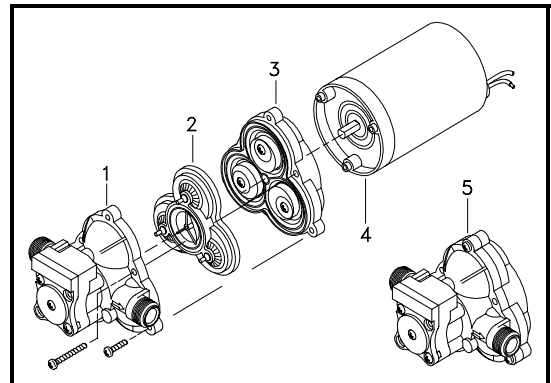

Number	Component	Parts Kit
1	Housing/Switch	94-231-24
2	Valve Assembly	94-232-06
3	Drive Assembly	94-238-04
4	Motor	11-242-10
5	Pump Head	94-236-08
Not Shown	Check Valve	94-237-00

Typical Performance @ 24 VDC

PRESSURE		FLOW		CURRENT
BAR	PSI	GPM	LPM	AMPS
0.0	0	2.8	10.5	1.6
0.7	10	2.2	8.3	2.1
1.4	20	1.8	6.9	2.4
2.1	30	1.3	4.9	2.5

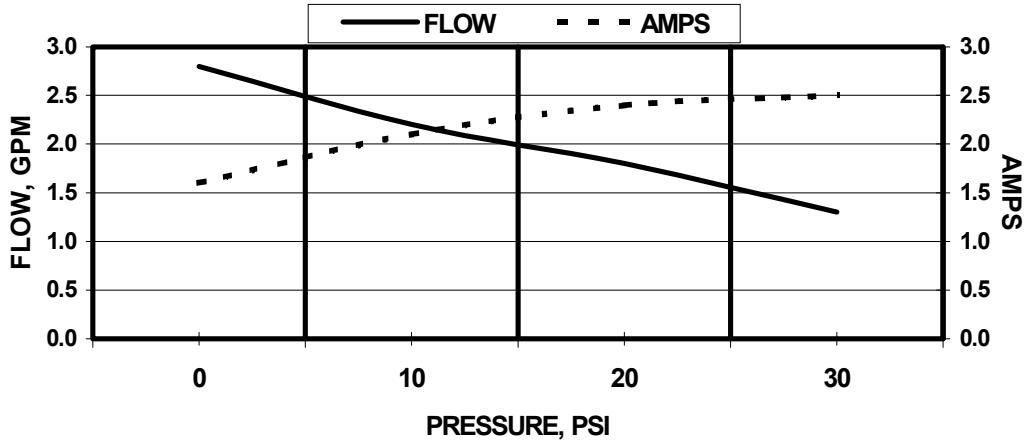

Typical Dimensions

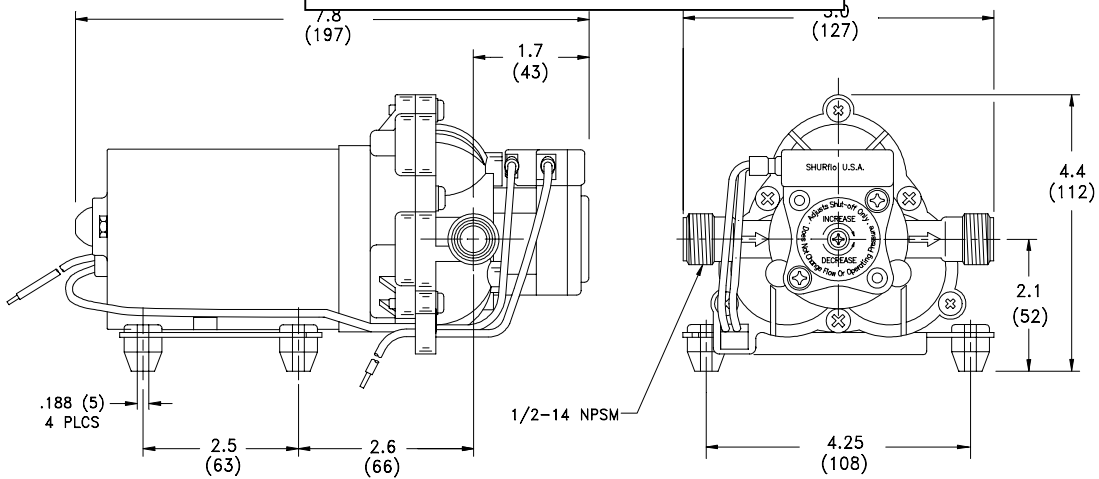

\* ISO Registered Facility

**SHURflo**  
First in Fluid Innovation

SHURflo reserves the right to update specifications, prices, or make substitutions.

SHURflo ★  
 12650 Westminster Ave.  
 Santa Ana, CA 92706-2100  
 (800) 854-3218 (714) 554-7709  
 FAX (714) 554-4721  
 Shipping/UPS: 12650 Westminster Ave.  
 Garden Grove, CA 92843

SHURflo East  
 52748 Park Six Court  
 Elkhart, IN 46514-5427  
 ((800) 762-8094  
 (219) 262-0478  
 FAX (219) 264-2169  
 © 2001

SHURflo Ltd.  
 Unit 5 Sterling Park  
 Gatwick Road, Crawley  
 West Sussex, RH10 2QT  
 United Kingdom  
 +44 1293 424000  
 FAX +44 1293 421880