



## MARINE PRODUCT DATA SHEET

OEM: 357-102-00 (1100 GPH)  
AFTERMARKET: 357-102-10 (1100 GPH)

Everything you are looking for in an aerator pump. Our tough, high density nylon housing and heavy duty water cooled motor give the SHURflo Aerator Pumps unparalleled reliability. Patented anti-airlock feature allows the pump to clear trapped air in rough water or when the boat is anchored. All Piranha Series Aerator Pumps have a removable cartridge for easy cleaning.

### TYPICAL APPLICATIONS

12V DC Bait/Livewell Application. For other applications, contact SHURflo.

### PUMP

Type: Centrifugal Pump  
Port (Outlet): 1 1/8" Barb  
Port (Inlet): 3/4" NPS-M  
Liquid: 130 °F [54 °C] Max  
Prime: Flooded Inlet  
Inlet PSI: 30 PSI [2.1 Bar] Max  
Run Dry: No

### ELECTRICAL

Motor: 12VDC Permanent Magnet, Continuous Duty  
Protection: External Fuse  
Leads: 6 ft (1.8M) Tinned, 16 AWG  
Fuse: 6 Amp Recommended  
Control: No Control

### MATERIALS

Housing: High Strength Nylon  
Impeller: high Strength Nylon  
Hardware: Stainless Steel

### APPROVALS

Ignition Protected, CE, ISO 8846

### WARRANTY

2 Year Limited Warranty  
See SB-1050 For Full Warranty Details

### SHIPPING

Net Weight (Boxed): 1.5 Lb (0.68 Kg) each  
Carton Weight: 27 Lb [12.2 Kg]  
Pumps in Carton: 18  
Carton Size: 24"L x 18"W x 11" H [61 cm x 46 cm x 28 cm]

### RELATED DOCUMENTS

Catalog: MS-030-140  
Installation Manual: 911-611-00  
Maintenance: 911-611-00  
Applications Spec Guide: MS-020-005  
Warranty: SB-1050

### Replacement Kit

94-620-00



PERFORMANCE @ 13.6V DC

PRESSURE		FLOW		CURRENT
METERS	FT OF HEAD	GPH	LPH	AMPS
0.0	0	1242	4700	4.80
1.80	6	420	1590	3.84
3.30	11	0.0	0.0	2.57

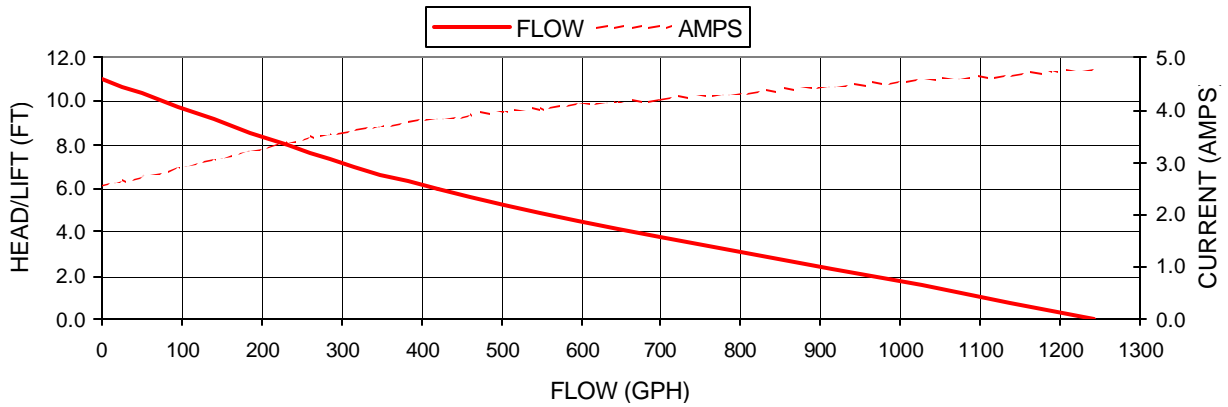

DIMENSIONS [mm]

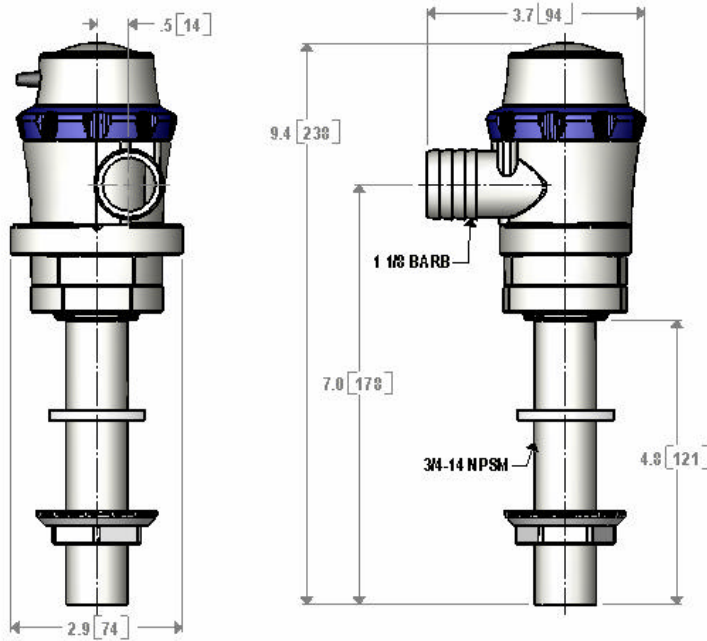

\*ISO Registered Facility

SHURflo reserves the right to update specifications, prices, or make substitutions.

SHURflo, LLC\*  
 5900A Katella Ave.  
 Cypress, Ca. 90630  
 Phone: 800 854 3218  
 Fax: 562 795 7554  
 Shipping: 5900C Katella Ave.  
 Cypress, Ca. 90630

SHURflo East  
 52748 Park Six Court  
 Elkhart, IN 46514-5427  
 Phone: 800 854 3218  
 Fax: 574 264 2169  
 Http://www.shurflo.com  
 © 2001

SHURflo Ltd.\*  
 Unit 5, Sterling Park  
 Gatwick Road, Crawley  
 West Sussex, RH10 9QT  
 United Kingdom  
 Phone: 0044 (0) 1293 424 000  
 Fax: 0044 (0) 1293 421 880

