

MARINE PRODUCT DATA SHEET

OEM 8050-305-426
 AFTERMARKET 8050-305-426



Oil Changer

TYPICAL APPLICATIONS

Oil change system. Other uses may include 12 VDC pressurized water systems, winterizing and liquid transfer. For other applications, contact SHURflo.

PUMP

Type: 3 Chamber Diaphragm
 Ports: 3/8" NPT-Female
 Liquid: 130 °F [54 °C] Max
 Prime: 6 feet [1.82 M]
 Inlet PSI: 30 PSI [2.1 Bar] Max
 Run Dry: Yes

ELECTRICAL

Motor: 12VDC Permanent Magnet, Continuous Duty
 Protection: Thermal Overload
 Leads: 8 feet with alligator clips
 Fuse: 7.5 Amp Recommended
 Control: 30 PSI Internal By-Pass (No External Control)

MATERIALS

Housing: Polypropylene
 Valves: Buna
 Diaphragm: Geolast 87 Shore
 Hardware: Stainless Steel

APPROVALS

c-UL Marine, Ignition Protected, ISO 8846

WARRANTY

1 Year Limited Warranty
 See SB-1041 & SB-1050 For Full Warranty Details

SHIPPING

Net Weight (Boxed): 8 Lb [3.6 Kg] each
 Carton Weight: 1 each, 8 Lb [3.6 Kg]
 Carton Size: 13"L x 13"W x 13"H
 [33 cm x 33 cm x 33 cm]

RELATED DOCUMENTS

Catalog: MS-030-084
 Installation Manual: 911-672
 Maintenance: 911-672
 Applications Spec Guide: MS-020-005
 Warranty: SB-1041 / SB-1050

Parts Kits

Number	Components	Parts Kits
9	Motor	Call SHURflo
5a	Valve Assembly	94-390-27
8	Drive Assembly	94-385-42



MARINE PRODUCT DATA SHEET

OEM 8050-305-426
 AFTERMARKET 8050-305-426



TYPICAL PERFORMANCE @ 12V DC WITH WATER

PRESSURE		FLOW		CURRENT
BAR	PSI	GPM	LPM	AMPS
0.0	0	1.55	5.86	2.2
0.7	10	1.45	5.48	2.8
1.4	20	1.36	5.14	3.5
2.1	30	1.10	4.16	4.1
2.8	40	0.15	0.56	4.4

TYPICAL MOTOR SHELL T-RISE @ 40 PSI, 12V

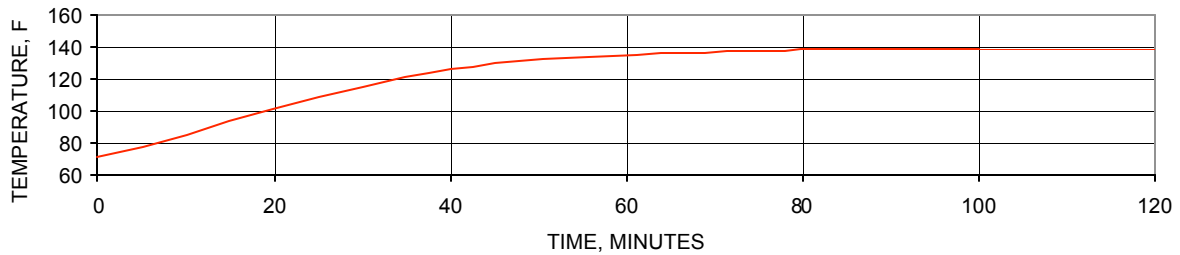

DIMENSIONS [mm]

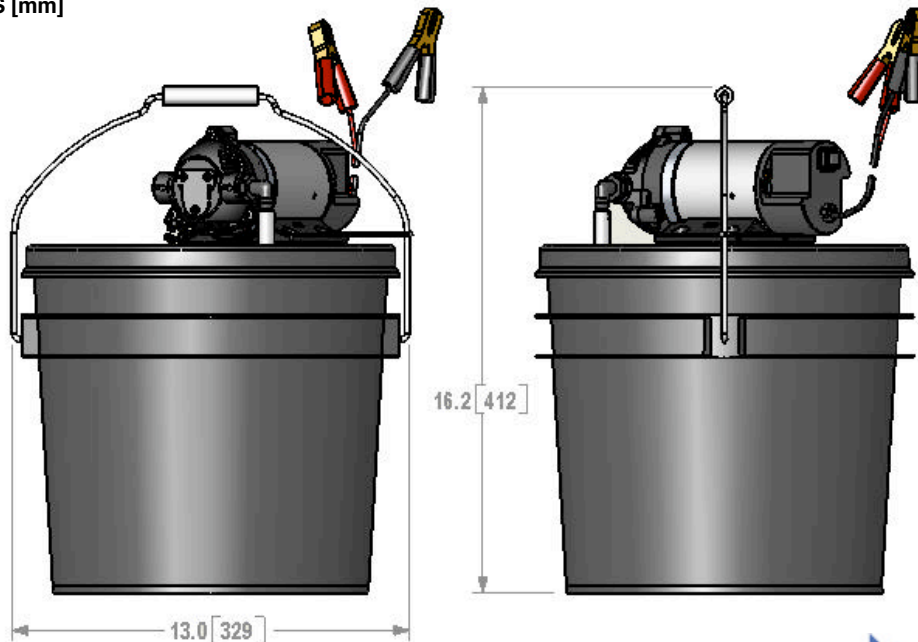

*ISO Registered Facility

SHURflo reserves the right to update specifications, prices, or make substitutions.

SHURflo *
 5900A Katella Ave.
 Cypress, Ca. 90630
 (800) 854-3218 (562) 795-5200
 FAX (562) 795-7554
 Shipping/UPS: 5900C Katella Ave.
 Cypress, Ca. 90630

SHURflo East
 52748 Park Six Court
 Elkhart, IN 46514-5427
 (800) 762-809 (574) 262-0478
 FAX (574) 264-2169
 Http://www.shurflo.com
 ©2001

SHURflo Ltd. *
 Unit 5 Sterling Park
 Gatwick Road, Crawley
 West Sussex, RH10 2QT
 United Kingdom
 +44 1293 424000
 FAX +44 1293 421880

