

CP Horizontal Double Casing Radially Split Multistage Pump

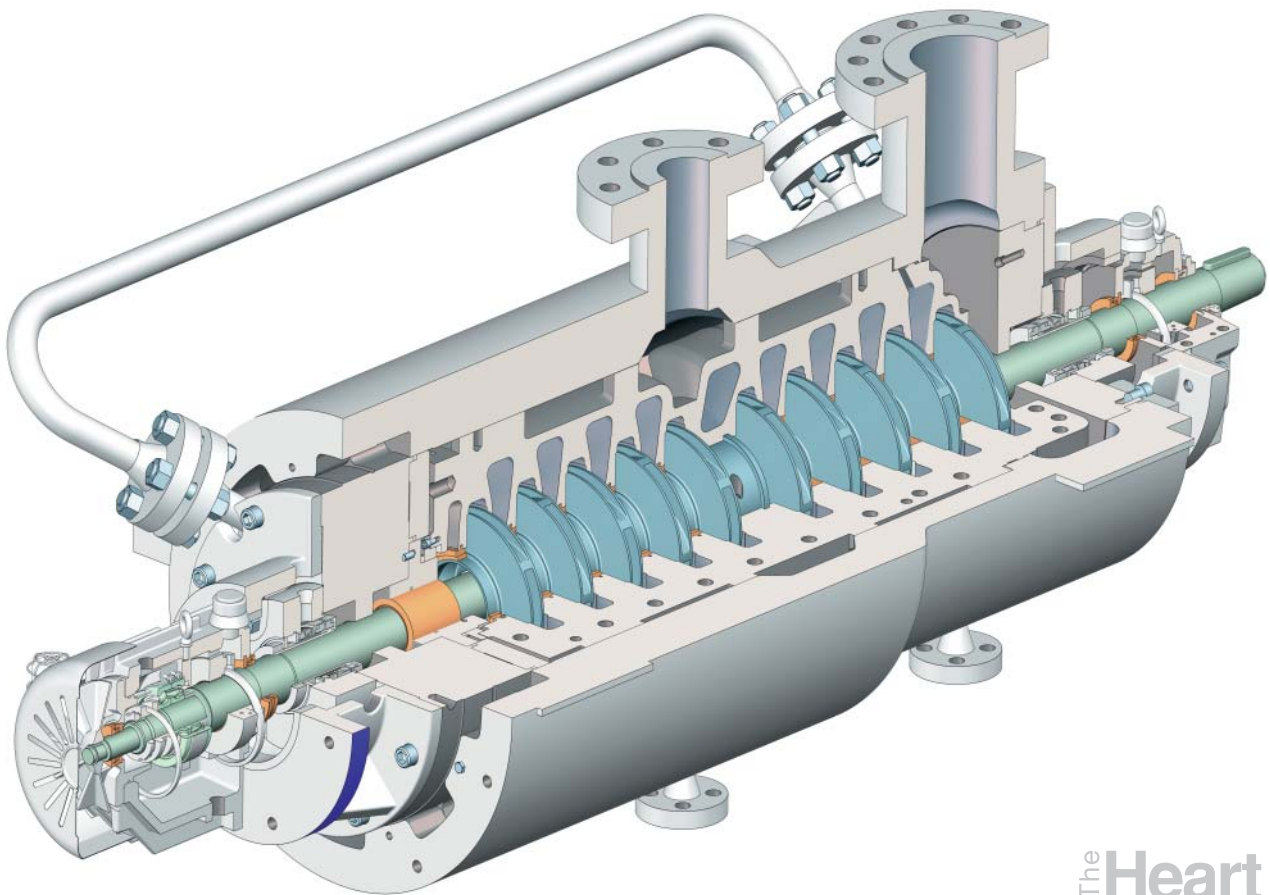

Sulzer Pumps

Sulzer Pumps is a leading global supplier of reliable products and innovative pumping solutions for end users. Our active research and development, detailed process and application knowledge together with a comprehensive understanding of market demands keeps us consistently at the leading edge of technical development. Our global network of modern manufacturing and packaging facilities together with sales offices, service centers and representatives located close to major markets provide fast responses to customer needs.



Sulzer Pumps is active serving business partners in the following industries:

- Oil & Gas
- Hydrocarbon Processing
- Pulp & Paper
- Power Generation
- Food, Metals & Fertilizers
- Water & Wastewater

Superior Reliability in Pumping Ensures Improved Productivity

The CP is a horizontal, API 610 BB5 axially split double case multistage barrel pump, with an opposed impeller, between bearing design. It is suitable for high pressure, high speed, high temperature services requiring reliability and long service life.

The CP's rotating element is housed in a horizontally split inner case, which is itself contained in a cast or forged outer barrel. This design provides for easy maintenance and element removal without piping disturbance. Suction and discharge nozzles are normally positioned at top centerline, but can be rotated to meet specific application requirements. Also, the CP can be supplied with a double-suction first stage for low NPSHa.

The opposed impeller and double volute inner case minimize axial thrust and control radial balance. These pumps are principally used in oil production, specialized refinery applications and for boiler feed

applications in power plants. They are particularly suited to low specific gravity applications where the back-to-back design and center bushing provide natural axial balance and additional shaft support.



Applications

Oil & Gas

- Refinery
- Petrochemical Services
- Crude Oil Transfer
- Water Injection

Power

- Boiler Feed

Hydrocarbon Processing

- Refinery
- Petrochemical

Sulzer's CP is a horizontal, API 610 BB5 axially split double case multistage barrel pump, with an opposed impeller, between bearing design. It is suitable for high pressure, high speed, high temperature services requiring reliability and long service life.

The CP's rotating element is housed in a horizontally split inner case, which is itself contained in a cast or forged outer barrel. This design provides for easy maintenance and element removal without piping disturbance. Suction and discharge nozzles are normally positioned at top centerline, but can be rotated to meet specific



application requirements. Also, the CP can be supplied with a double-suction first stage for low NPSHa. The opposed impeller and double volute inner case minimize axial thrust and control radial balance. These pumps are principally used in oil production, specialized refinery applications and for boiler feed applications in power plants. They are particularly suited to low specific gravity applications where the back-to-back design and center bushing provide natural axial balance and additional shaft support.

Sulzer Twistlock™ Design

The CP pump discharge cover incorporates the innovative Sulzer Twistlock™ design, which significantly reduces the pump assembly and disassembly time. This feature also leads to a decrease in the weight of the pump unit compared with the traditional heavy bolted design. The suction cover is a simple design that provides effective sealing and again eliminates the usual requirement of heavy bolting. End covers contain integral seal chambers that comply with the requirements of ISO 13709 (API 610) Table 6 and ISO 21045 (API 682). The traditional bolted design end covers can be made available for customers who mandate the arrangement as a technical requirement.



Sulzer Twistlock™ technology for superior functionality, reduced overall weight and proven time savings for assembly and disassembly.

CP Design Features and Options

O-Ring or pure graphite sealing rings for operating temperatures up to 425°C (800°F)

Twistlock™ discharge cover; Traditional bolted design available

Bearing options to suit specific applications:

- Ball/ball
- Sleeve/ball
- Sleeve/pivot shoe

Flanges ratings up to ASME B16.5 Class 2500 with option to have suction end rated equal to discharge. Graylok and other flange designs available.

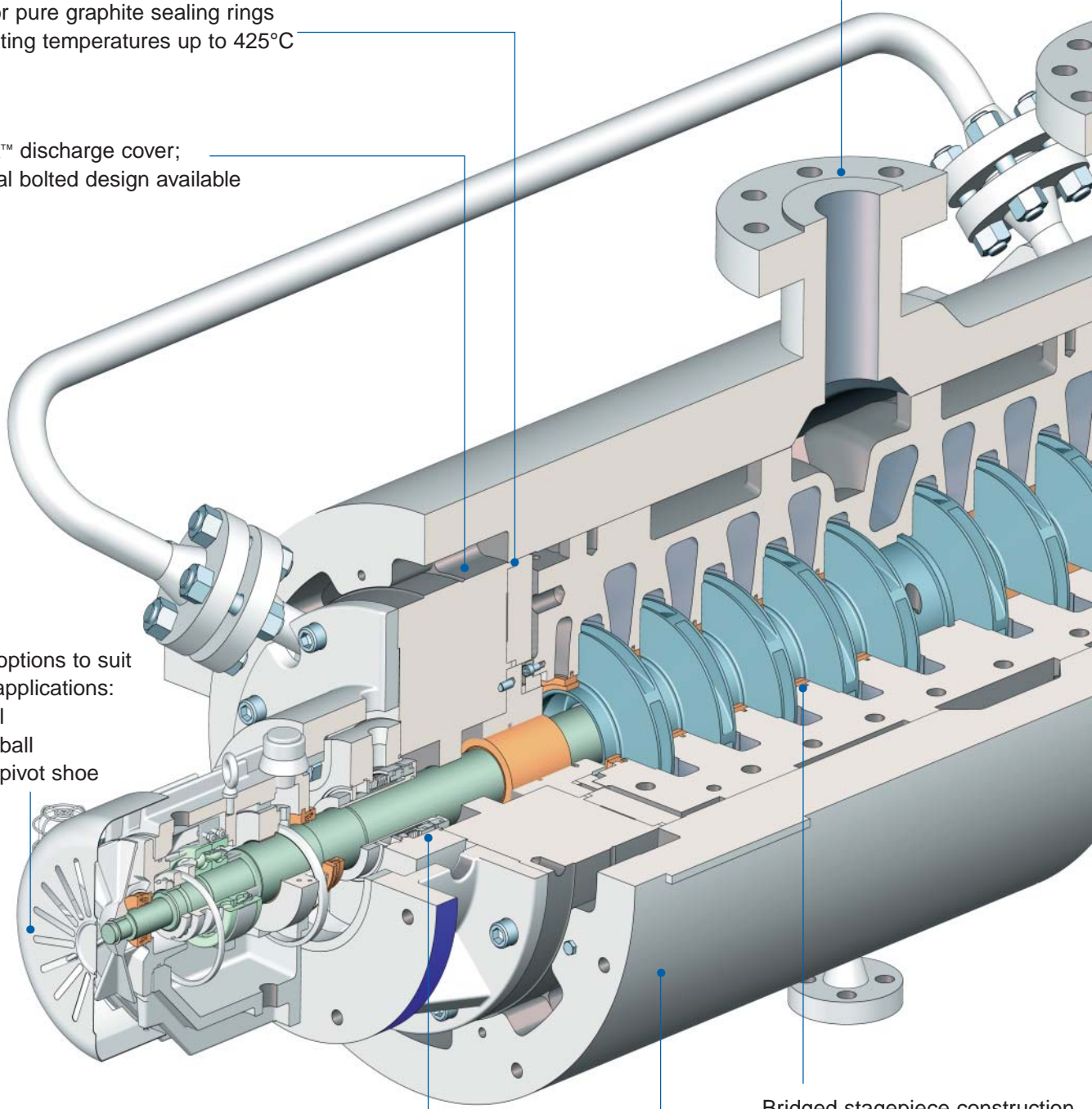

ISO 24109 (API 682 2nd Edition) seal chambers and flush piping for improved seal life

Numerous pump metallurgies to meet wide variety of arduous pumpages

Bridged stagepiece construction for reduced number of wear part components

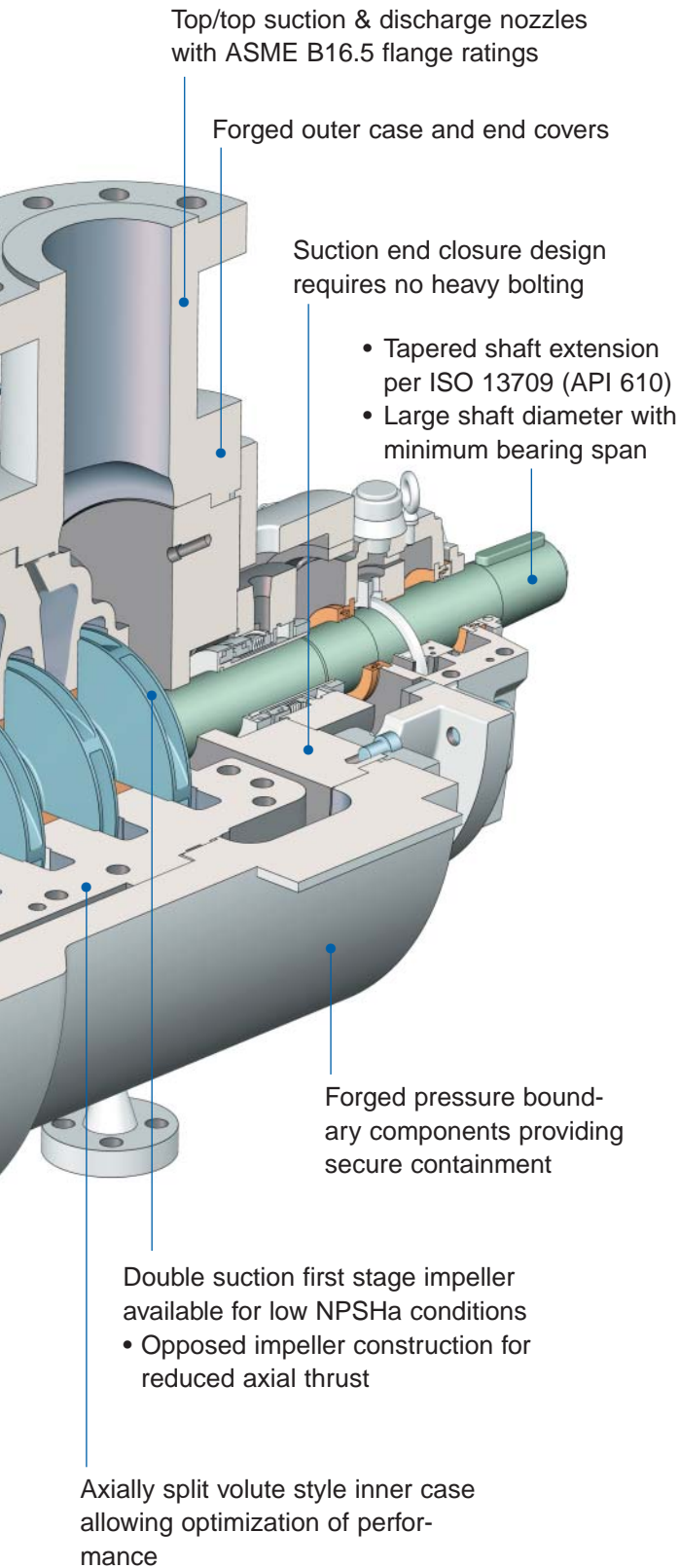

Standard Features

- Compliance with ISO 13709 (API 610) requirements
- Hot alignment feature for temperatures above 120°C (250°F)
- Designed to accommodate temperatures between -29°C (-20°F) to 425°C (800°F)
- Pump feet located on horizontal centerline
- Inner bundle arrangement (rotating element and volute case) for ease of changeouts
- Seal chambers for single/double seals to ISO 13709 (API 610) Table 6
- Flanged stationary wear parts to control interstage leakage
- Double volute inner case for radial thrust balance
- Replaceable or integral impeller hub and eye rings
- Dynamically balanced impellers and rotating element
- NEMA taper shaft extensions for spacer couplings
- Rotation counterclockwise, as viewed from the driver

Options

- Twistlock™ discharge cover for quick assembly/disassembly
- Super Bolt™
- Bearing arrangements and lube systems
- Seals and piping
- Cooling jackets
- Custom baseplate for special drivers
- Metallurgy combinations
- Top/side or side/side or bottom nozzle locations
- Bolted endcovers
- Non-metallic wear parts
- De-staged construction
- Hydraulic fit couplings
- Clockwise rotation, as viewed from the driver
- Full cartridge design
- Additional inspection and NDT (to meet ISO 13709 (API 610) bulleted requirements)
- Instrumentation including vibration, temperature and pressure monitoring
- ISO 13709 (API 610) flush and cooling plans

CP Performance Range

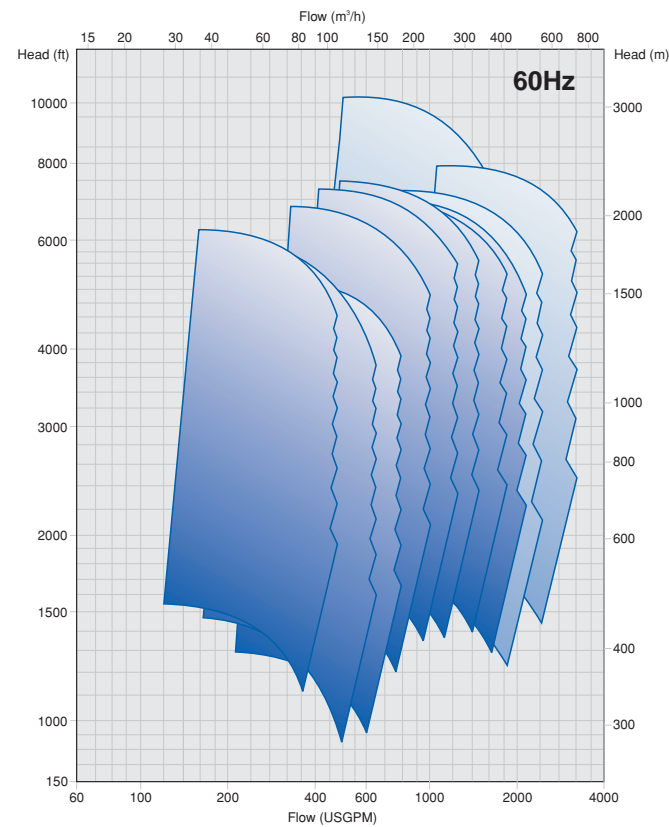
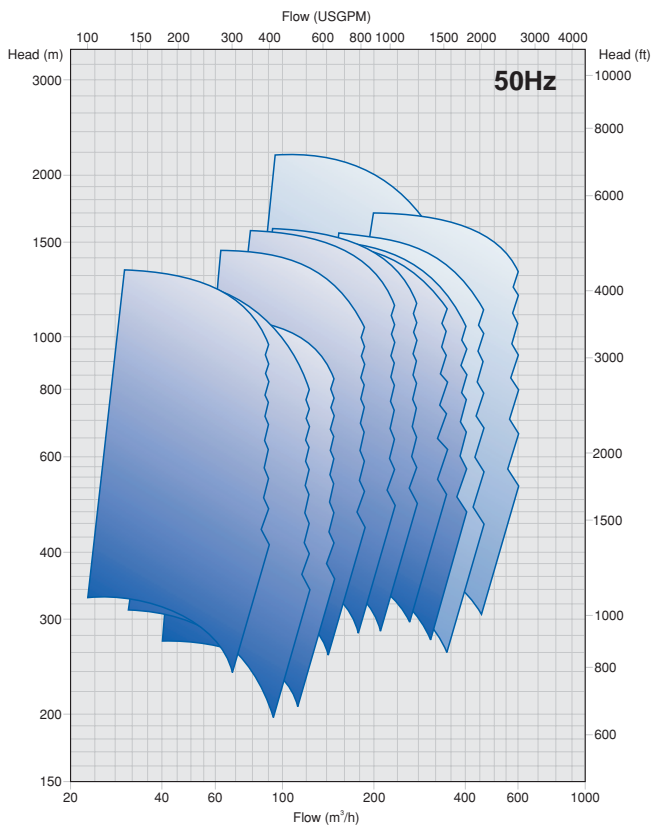

Note: Head and flow lines from maximum (runout) flow to minimum flow capacity.

Operating Data

	50 Hz / SI units	60 Hz / US units
Capacities	up to 590 m ³ /h	up to 2,600 gpm
Heads	up to 2,525 m	up to 8,280 ft
Pressures	up to 425 bar	up to 6,250 psi
Temperatures	-28° to 425°C	-20° to 800°F
Speeds	up to 7,200 rpm	up to 7,200 rpm

Note: Higher performances met with custom designs.
Head and flow at the best efficiency point.

Striving to Serve You Better

Your Global Partner

Sulzer operates over 20 test facilities worldwide. Our facilities are suitable for horizontal or vertical, open pit, high flow rate/high energy and multiphase testing. We have the ability to perform tests at 50 and 60Hz and, depending on the site, are able to operate using diesel engines, gas engines and gas turbines in addition to conventional electric motors.

A specialty of Sulzer is the ability to fully string test large high-energy pumps to prove the pump package as a whole to our customers. This ability is particularly important for critical offshore applications where on site correction is both expensive and time consuming.

Customer Support Service

Through our worldwide network of over 50 service centers we provide our customers with a full range of services for pumps and other associated equipment. Local 24 hours a day, 7 days a week customer service backed up by our service groups' global solutions, concept development and support team. Applying our

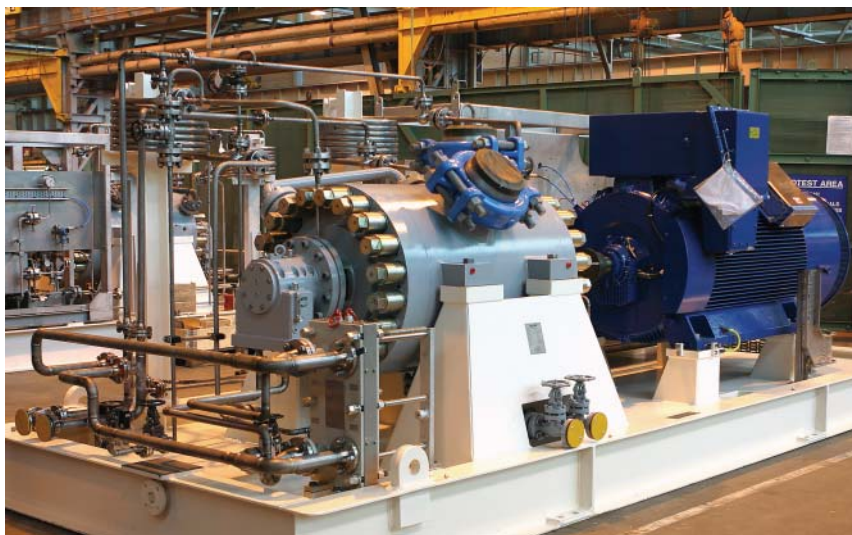

unique combination of experience and expertise, we are consistently able to deliver high quality, value added rotating equipment support. Furthermore, we can also design, deliver and fit high integrity components for non-Sulzer machinery using our in-house reengineering specialists.

Sulzer Customer Alliances

Sulzer Pumps' business strategy is simply to work closely with our partners to gain an understanding of their requirements and expectations, and provide products

and services which meet those expectations better than anyone else. We can look back on 10 years of alliance experience. Our customer alliance agreements are key to our strategy and represent a mutual long term commitment for the purpose of achieving world class pumping system life cycle cost by maximizing the effectiveness of our partner's and Sulzer's resources. Sulzer currently has agreements with many of the major oil companies focusing on solving problems and simplifying work processes.

Network of Locations

- Divisional Headquarters
- Manufacturing Facility
- Customer Support Service Center (CSS)
- Sales Office

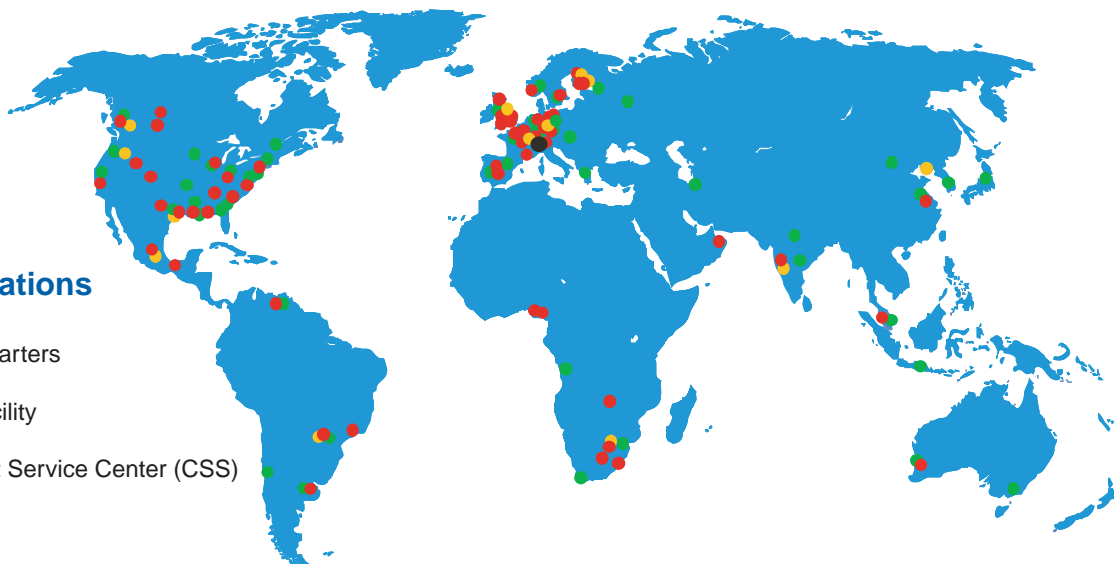



Check our worldwide offices at
www.sulzerpumps.com