

UP-170-F  
 UP-270-F  
 UP-440-F  
 UP-580-F

# Pond Filter Pumps

*Submersible Pumps for Decorative Fountains, Waterfalls and Aquariums*

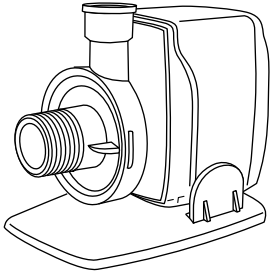

Threaded Adapter

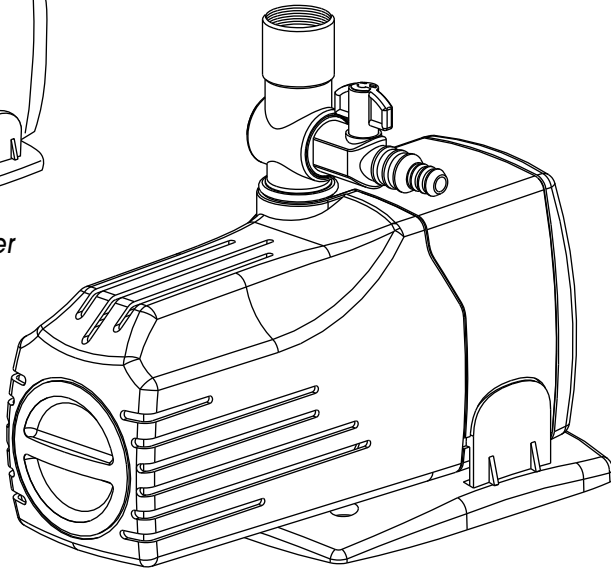

*Accessories sold separately.  
 See available fountain accessories on pages 16 and 17.*

## Pump Performance Chart

Stock No.	Watts	Max Head	GPH	6"	1'	2'	3'	4'	5'	6'	7'	8'	9'	L	W	H
UP-170-F	13.5	51"	185	170	155	115	80	20	0	0	0	0	0	5-1/2"	2-3/8"	3-1/8"
UP-270-F	16	59"	240	230	215	180	135	50	5	0	0	0	0	7-1/4"	3-7/8"	3-7/8"
UP-440-F	29	92"	430	410	400	350	300	250	200	140	75	5	0	8-5/8"	3-5/8"	4-3/8"
UP-580-F	53	98"	540	520	500	460	400	330	275	200	125	25	0	8-5/8"	3-5/8"	4-3/8"

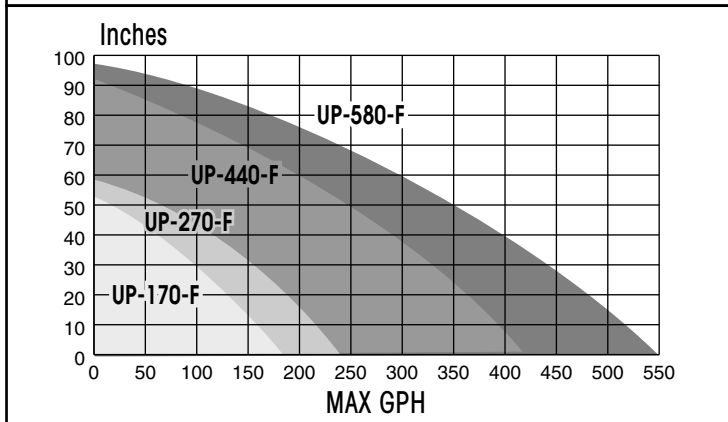

- Energy saving, low operating cost.
- Ceramic-coated 316 stainless steel shaft for ultimate durability.
- Complies to all international and domestic safety standards (UL listed).
- Outlet 1/2" female threaded.
- 1/2" MIP inline adapter models UP-170 and UP-270.
- 1" MIP inline adapter models UP-440 and UP-580.

**UNITED PUMP INC.**



United Pump, Inc.  
 2357 Ventura Dr., Suite 102  
 Woodbury, MN 55125

Phone: 651-731-1001  
 Fax: 651-731-8404

*United Pump's pumps are efficient and reliable. These pumps may be disassembled without the use of tools for easy cleaning.*